



**ALUMINIUM**  
**CURTAINWALL & METAL CEILING**

**铝幕墙 金属天花**





**NAVIGATION**,  
**THE ATTITUDE OF PIONEER**  
 航领，先锋之态

## 产品目录 Products Contents

铝单板系列 Single Panel of Aluminium Series	07
户外幕墙 Outdoor Aluminium Wall Panel	09
室内幕墙 Indoor Aluminium Wall Panel	11
<hr/>	
方板系列 Square Panel Series	13
暗架方板 Clip-in Ceiling	13
明架方板 Lay-in Ceiling	19
井型方板 Well-shaped Ceiling	23
<hr/>	
U型方槽 U-Shaped Square-groove Ceiling	25
<hr/>	
圆通天花 Round Tubular Ceiling	29
<hr/>	
格栅天花 Grid Ceiling	31
<hr/>	
挂片天花 Screen Ceiling	35
7型挂片 7-shape Screen Ceiling	35
鹰嘴挂片 Olecranon Screen Ceiling	37
<hr/>	
条扣系列 Strip Ceiling Series	39
C型条扣 C-shaped Strip Ceiling	39
S型防风条扣 S-shaped Strip Ceiling	41
G型条扣 G-shaped Strip Ceiling	43
覆膜系列 Film Faced Series	45
<hr/>	
吸音系统 Sound Absorption System	47
<hr/>	
修边角系列 Revised Corner Series	48
<hr/>	
方板冲孔花式 Square Plate Punching Fancy	49
<hr/>	
工程案例展示 Project Case Show	51
<hr/>	
部分工程名录 Section Project Directroy	58

产品平台



Products platform



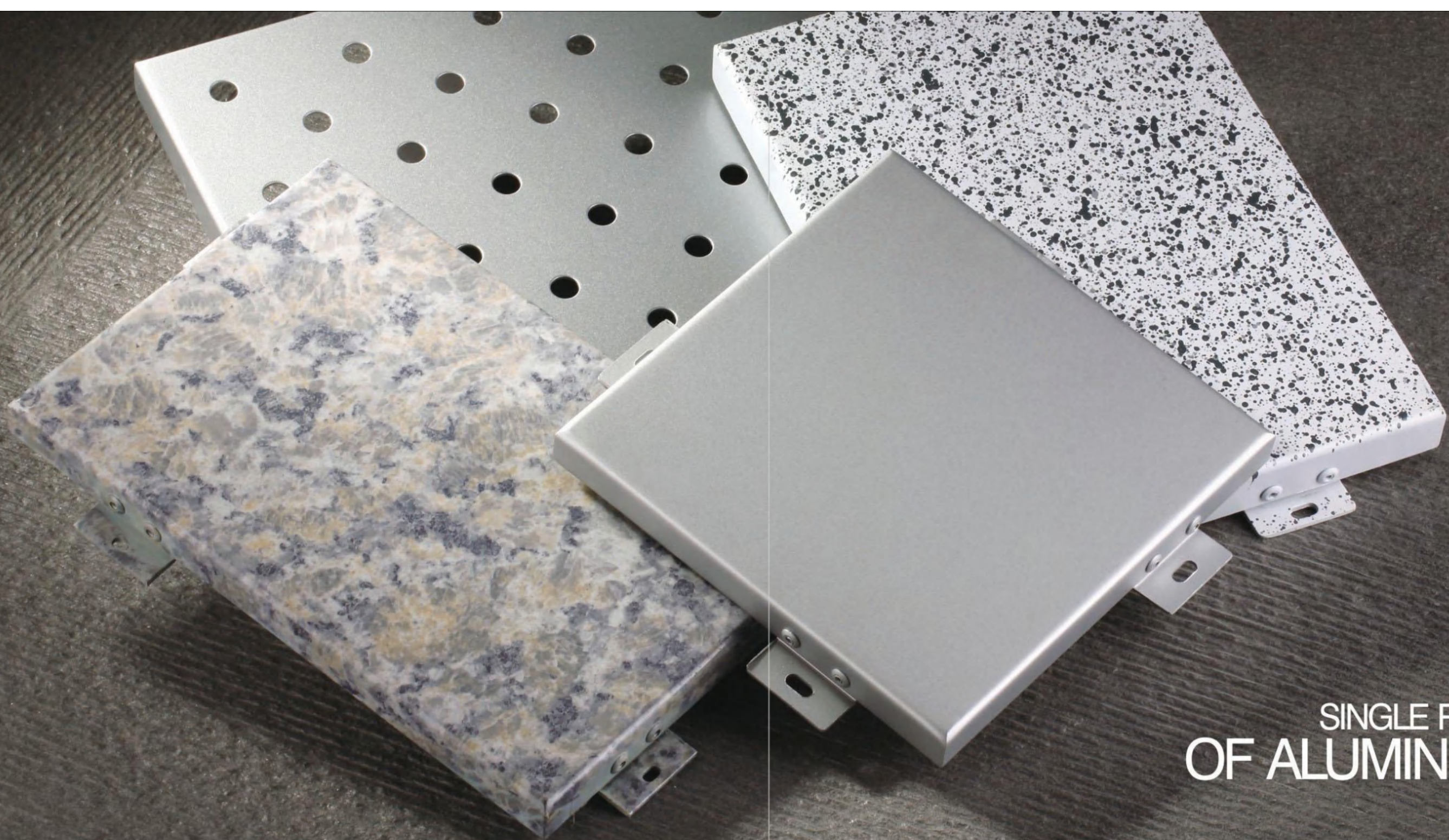

# SINGLE PANEL OF ALUMINIUM

铝单板

铝单板构造图 Structure Diagram of Single Aluminium Plate



铝单板幕墙表面一般经过铬化等前处理后，再采用氟碳喷涂处理。氟碳涂层具有卓越的抗腐蚀性和耐候性，能抗酸雨、盐雾和各种空气污染物，耐冷热性能极好，能抵御强烈紫外线的照射，长期保持不褪色、不粉化，使用寿命长。

Having been chromized firstly, then, the aluminium single plate is processed with fluorocarbon spray coating. Fluorinecarbon coating has outstanding characteristics of corrosion resistance and weathering resistance, resisting acid rain, salt fog and various kinds of air contaminants. Besides, it has good performance of thermal and cold endurance, meanwhile, it can resist strong ultraviolet ray, keeping unfading and chalking with long life-time application.

# OUTDOOR ALUMINIUM WALL PANEL 户外幕墙

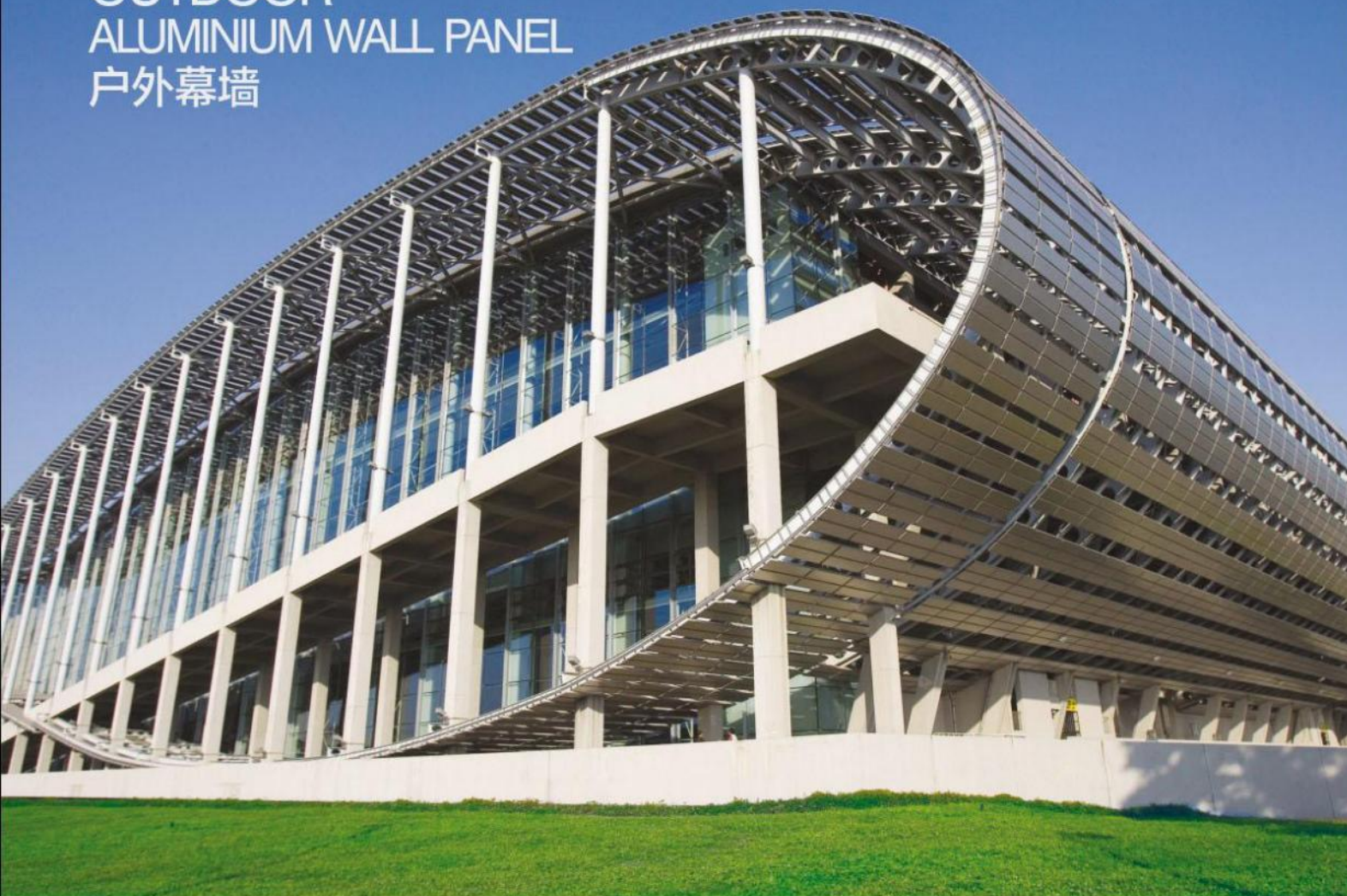

- 户外幕墙采用优质高强度铝合金板材，主要由面板、加强筋和角码组成。角码可直接由面板折弯、冲压成型，也可在面板的折边上铆装角码成型。加强筋与板面后的电焊螺钉联接，使之成为一个牢固的整体，极大增强了铝单板幕墙的强度与刚性，保证了长期使用中的平整度及抗震能力。
- 适用于建筑幕墙、室外装饰、广告标志牌、仪器外壳、人行天桥、地铁站、海运工具。

● Its structure of which is made up of front-plate, reinforced rib, and angle is processed by high-intensity aluminium alloy material. The front-plate can be directly bent and stamped to the shape of angle, meanwhile, it is to be made by riveting on the front-plate flanging. The reinforced rib is jointed by the electrical welding bolt at the back of plate, so as to form the whole structure. Therefore, greatly reinforces the intensity and strengthen characters to aluminium single plate curtain wall, guaranteeing evenness and shock resistance ability.

● Used in building walls, outdoor decoration, advertising signs, equipment enclosures, pedestrian bridges, underground, sea tools.

幕墙墙面转角大样图  
General Graphic of Curtain Wall Corner

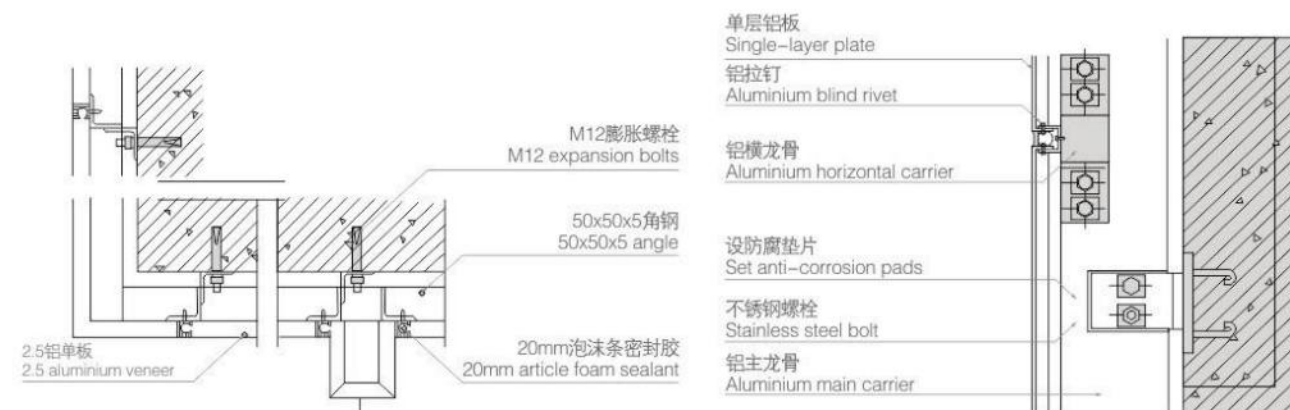

INDOOR  
ALUMINIUM WALL PANEL  
室内幕墙



- 室内幕墙采用高强度的优质AA级铝合金材料精加工而成，产品经前处理后，再采用氟碳喷涂处理，设计掺入现代、时尚等创新元素，让建筑更具现代感。
- 适用于梁柱、隔板包饰、大堂门面、屋顶平面、室内隔墙、车船内饰及大幅度吊顶等。

- Indoor aluminium wall panel is taken high-intensity and superb AA grade aluminium alloy material as its original material, through the pre-treatment, then to use fluorine-carbon spray coating to process, so it will definitely show its modern and latest element to its design aspect, making its to have more modernized ideas.
- Used in beams, partitions package decoration, lobby facade, flat roof, interior walls, ceiling and other travel and big interior.

铝板包柱安装实例

Installation Illustration of  
Aluminium Plate Decoration for Pillars

耐候密封胶 Weather-resistant sealant

自攻螺丝 Self-tapping screw

膨胀螺栓 Expansion bolt

铝方管 Aluminium square tube

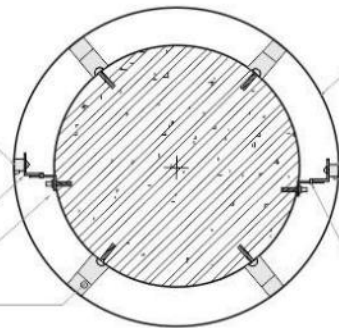

铝单板 Aluminium single plate

泡沫条垫衬 Foam bar cushion

挂耳交错安装 Side notching interlaced installation

角钢调平后焊接并做防锈处理  
The leveling angle after welding and antirust processing

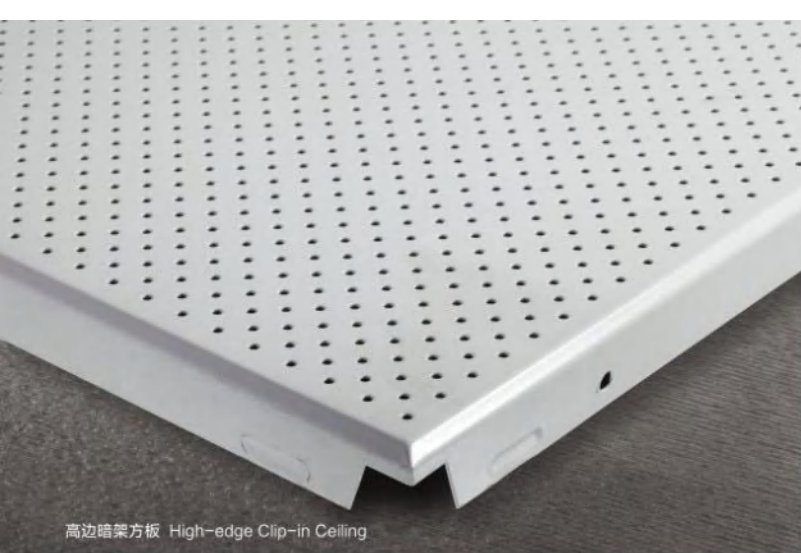

高边暗架方板 High-edge Clip-in Ceiling

## CLIP-IN CEILING SERIES 暗架方板

- 暗架方板板面平整无痕，拼接无缝，风格鲜明，色彩丰富，款式多样，经久耐用，品质优良，高贵典雅，具有完美的吸音效果，也可与方板和长条板组合使用。
- 具备防火、防潮、防腐、易清洁的优点，结构轻巧，装拆方便，每块板都打有卡位定位，保证安装平整度，对隐蔽工程遮盖性强，确保了天花整体的一致与美观。
- Flat surface without gap, vivid style, various colors and size, forever used, excellent quality, noble and elegant, perfect effect of sound-proof, also can be use by collocation between slats and squareness.
- Have advantage of fire-proof, damp-proof, resistance to corrosion, and easy to clean, light structure, conveniently install and tear down, each board have its positioning hustle, made sure that it's smoothly install, have strong coverage to concealed works, guarantee uniformity and aesthetics of whole ceiling.

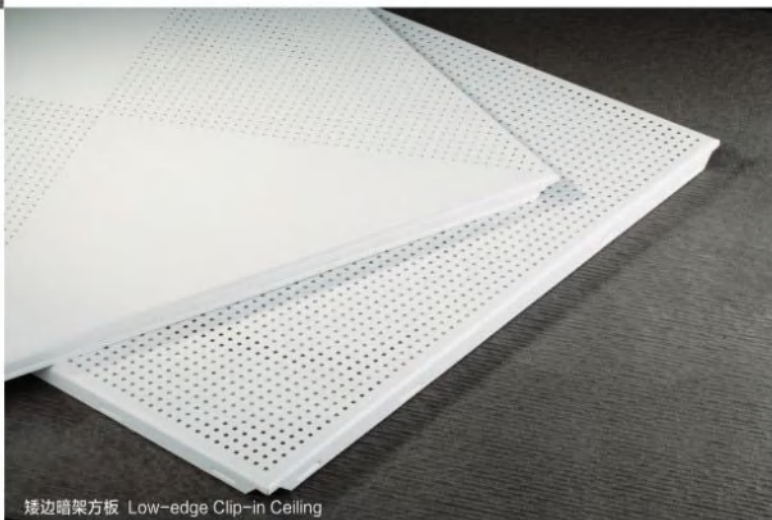

矮边暗架方板 Low-edge Clip-in Ceiling

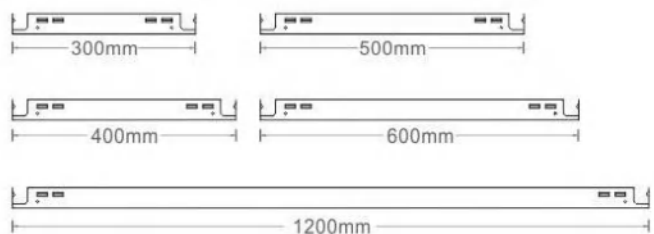

规格(W×L)	300×300mm 600×600mm 600×1200mm	400×400mm 300×600mm	500×500mm 300×1200mm
厚度(D)	0.6-1.2mm		
边高(H)	25mm	30mm	
备注	夹入式 平面 冲孔系列		
A型龙骨(H)	38mm	50mm	



CLIP-IN  
CEILING SERIES  
暗架方板



高边暗架方板安装结构图  
Structure Diagram of High-edge Clip-in Ceiling

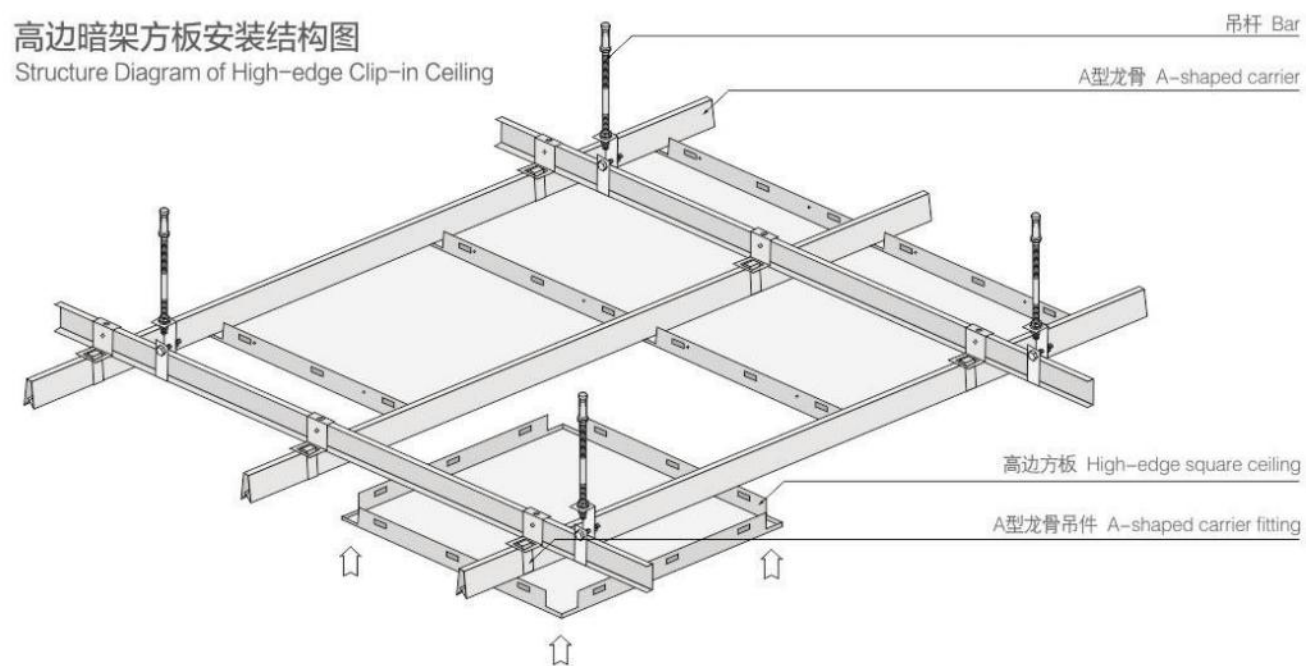

矮边暗架方板安装结构图  
Structure Diagram of Low-edge Clip-in Ceiling

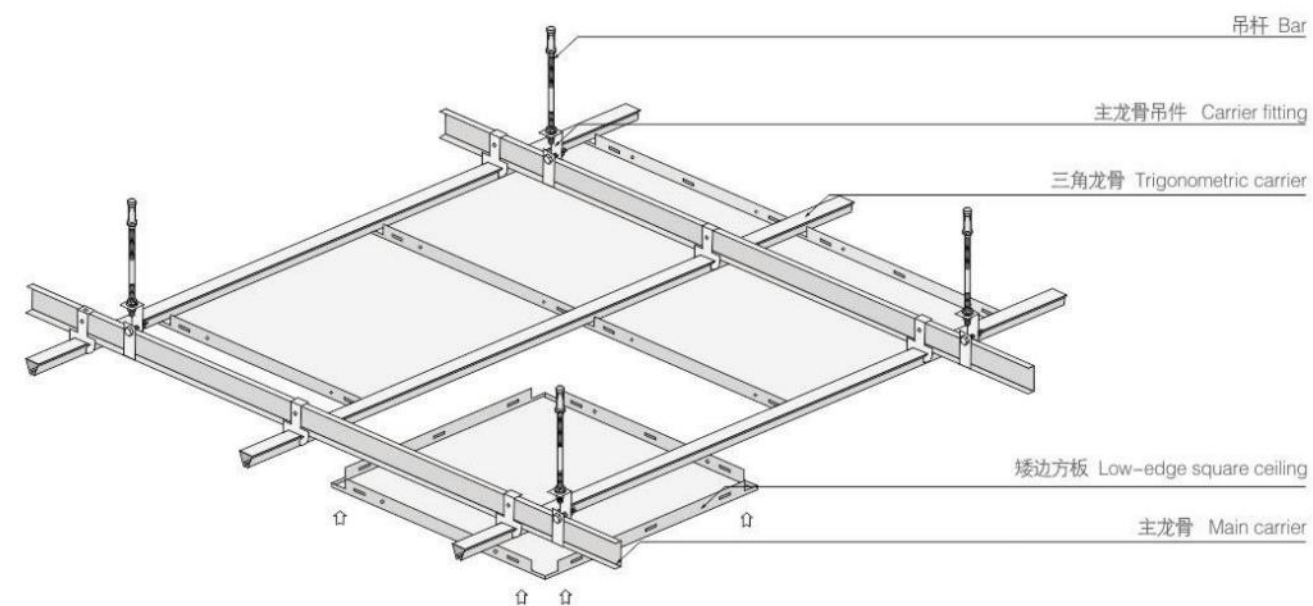

# CLIP-IN CEILING SERIES 暗架方板

- 暗架方板款式多样，依据不同尺寸的暗架方板进行搭配，可方板和长条板组合。每块板都打有卡位定位，保证安装平整度；可选择布孔，形成吸音效果。
- 适用于商场、超市、室外设施、加油站、收费站、地铁站、火车站、机场、长途汽车站、学校、办公室、会议室、建筑物的大堂、走廊和卫生间、体育场馆。
- Clip-in ceiling has various patterns, collocating according to different size, it's available to combine square board with long board. Every board has knot position, make sure flatness of the board, there are fabric hole to found sound-absorbing effect.
- Used in shopping malls, supermarkets, outdoor facilities, gas stations, toll stations, subway, railway stations, airports, bus stations, schools, offices, meeting rooms, building lobbies, corridors and toilets, sports venues.

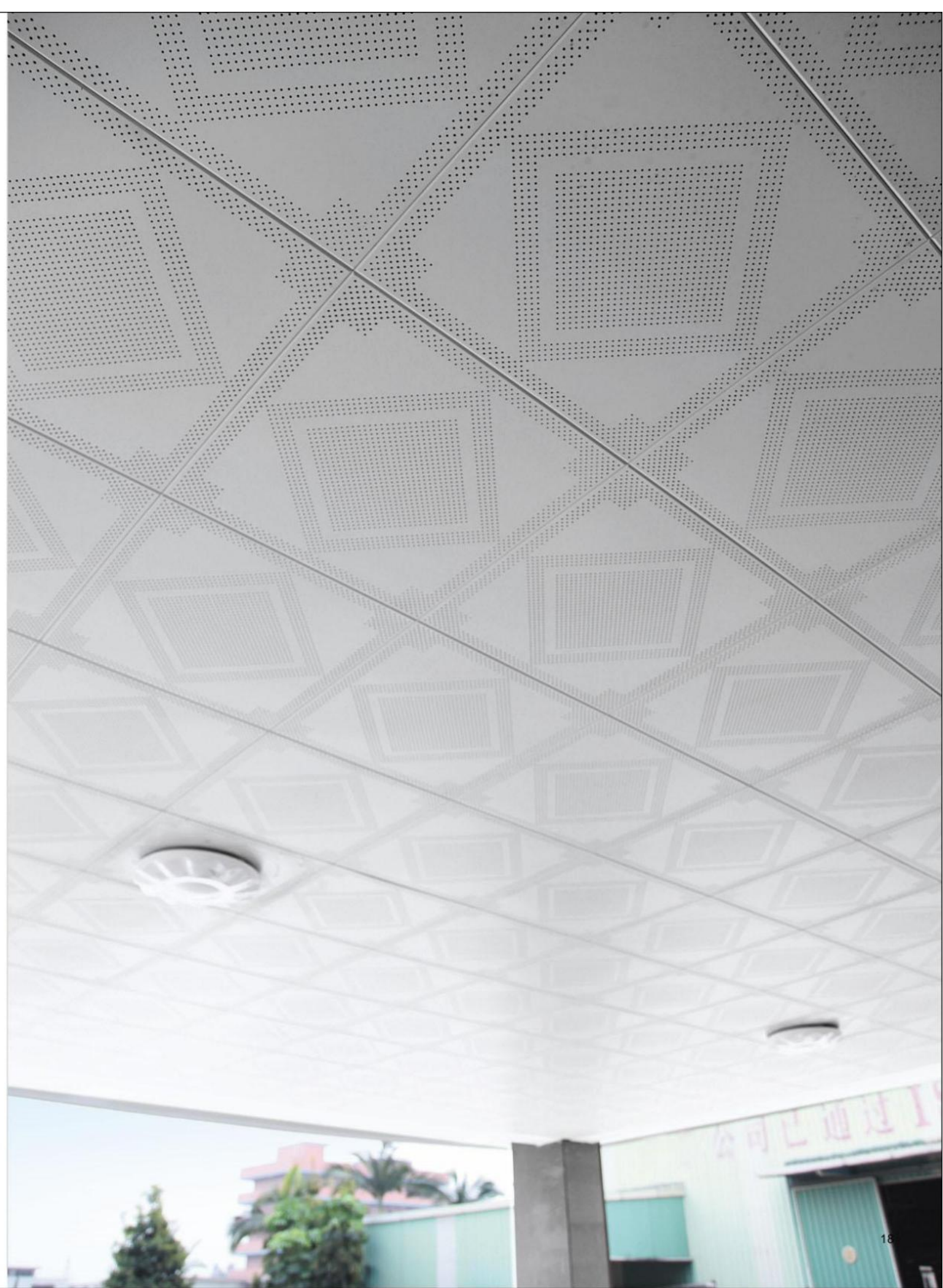
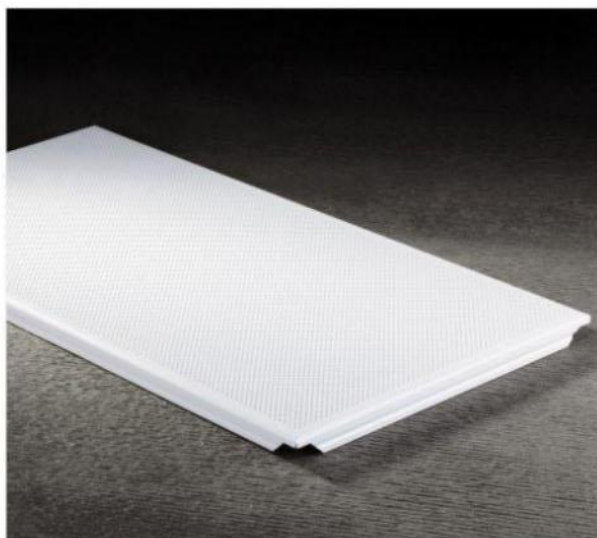

# LAY-IN CEILING SERIES 明架方板

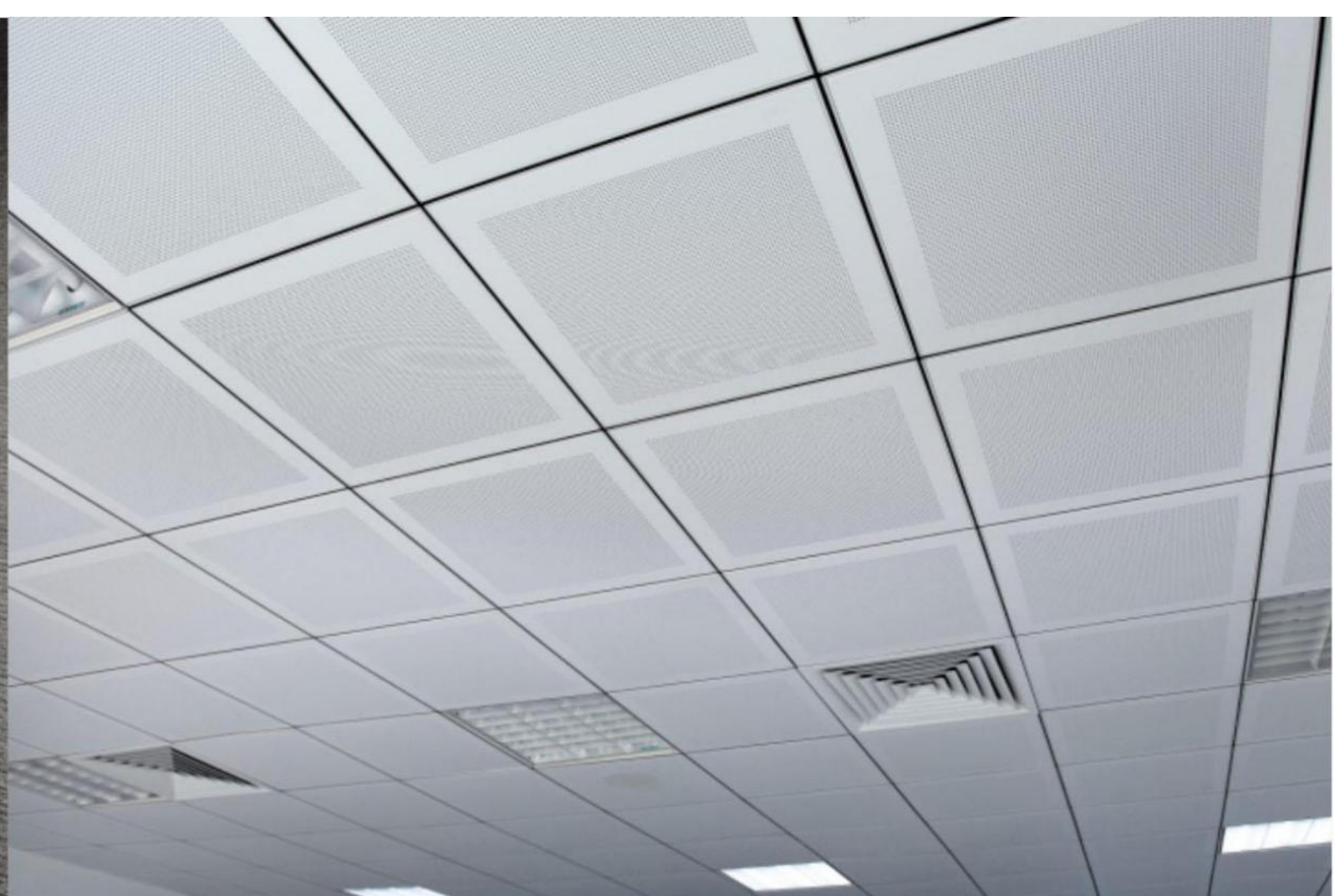
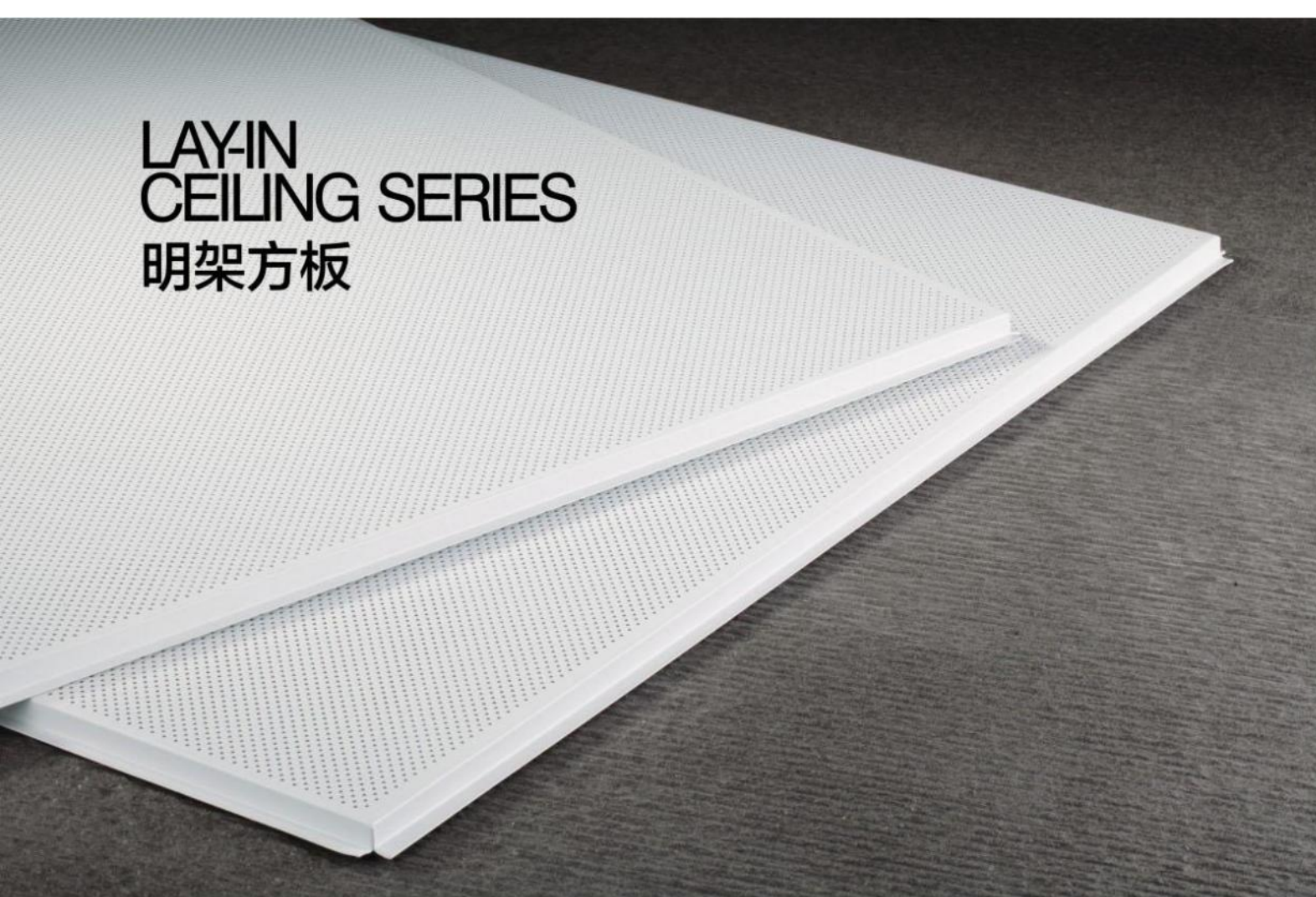

## 龙骨系列 Carrier Series

T型烤漆主龙骨  
Main carrier of T-shaped  
baking varnish ceiling

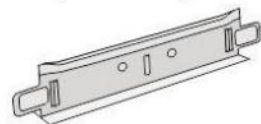

T型烤漆副龙骨  
Vice carrier of T-shaped  
baking varnish ceiling



铝U型主龙骨  
Main carrier of U-shaped  
square-groove ceiling

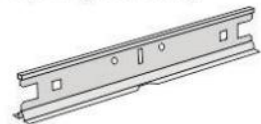

铝U型副龙骨  
Vice carrier of U-shaped  
square-groove ceiling

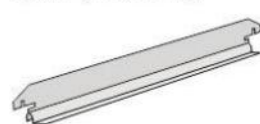

铝大方槽主龙骨  
Main carrier of aluminium  
square-groove ceiling

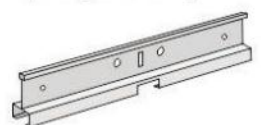

铝大方槽副龙骨  
Vice carrier of aluminium  
square-groove ceiling

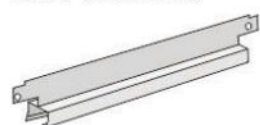

板面(W×L)	575X575mm	583X583mm	585X585mm
板边(W×L)	595X595mm	603X603mm	
厚度(D)	0.5-1.0mm		
边高(H)	8mm	10mm	15mm 20mm



明架斜角边方板  
Oblique-edge square panel of lay-in ceiling

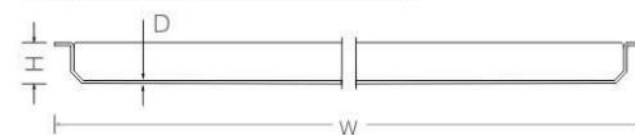

明架直角边方板  
Right-edge square panel of lay-in ceiling

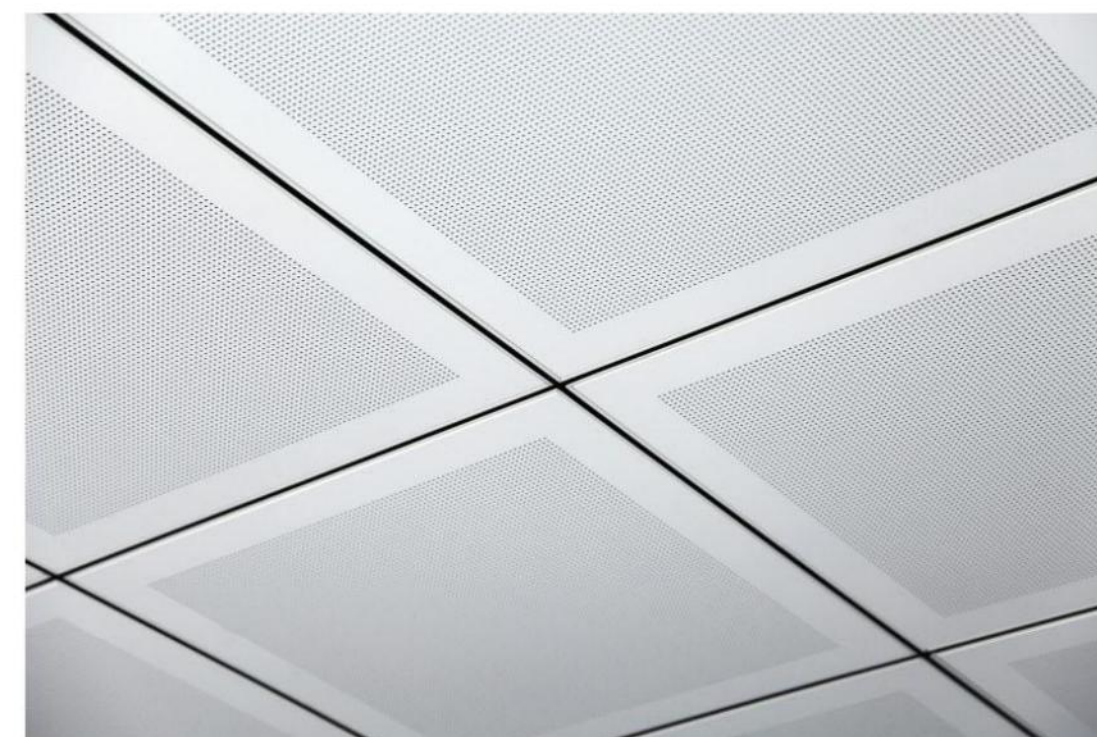

# LAY-IN CEILING SERIES 明架方板

明架方板由装饰面板、明骨、上层轻钢主龙骨以及相关配件共同构成。板面平整，线条明快，立体感更强。每件板均可独立拆装，方便施工、维护和清洁。设计时可定制龙骨的宽度并利用灯光及通风配件的组合营造出不同的线条效果。

The ridged square ceiling contains three parts: the panel system, the ridged carrier system, and the upper light steel carrier system. The ridged square ceiling is with a smooth surface, flowing lines and stronger third dimension. As every gusset plate can be installed and dismantled individually, it is very convenient to install, maintain, and clean. It also could create different effect with different lines by combination of lighting and air piece when designing.



明架方板安装结构图  
Structure Diagram of Lay-in Ceiling

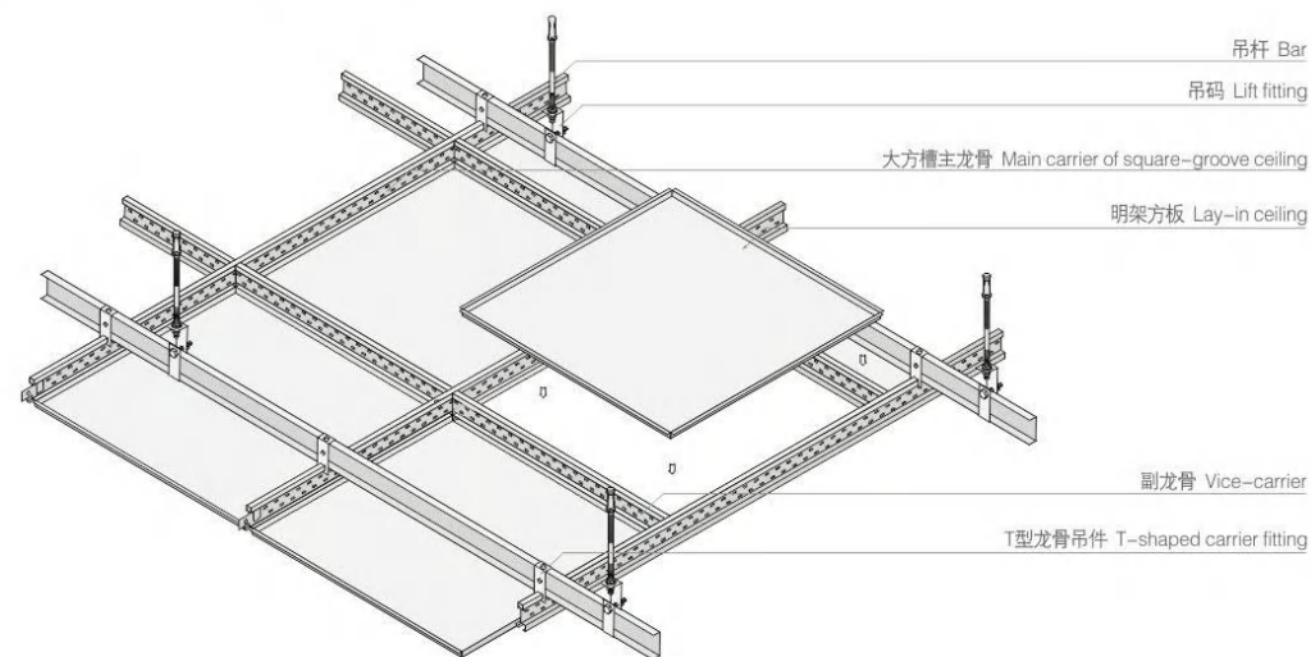

# WELL-SHAPED CEILING

## 井型方板



深井型天花铺贴效果图

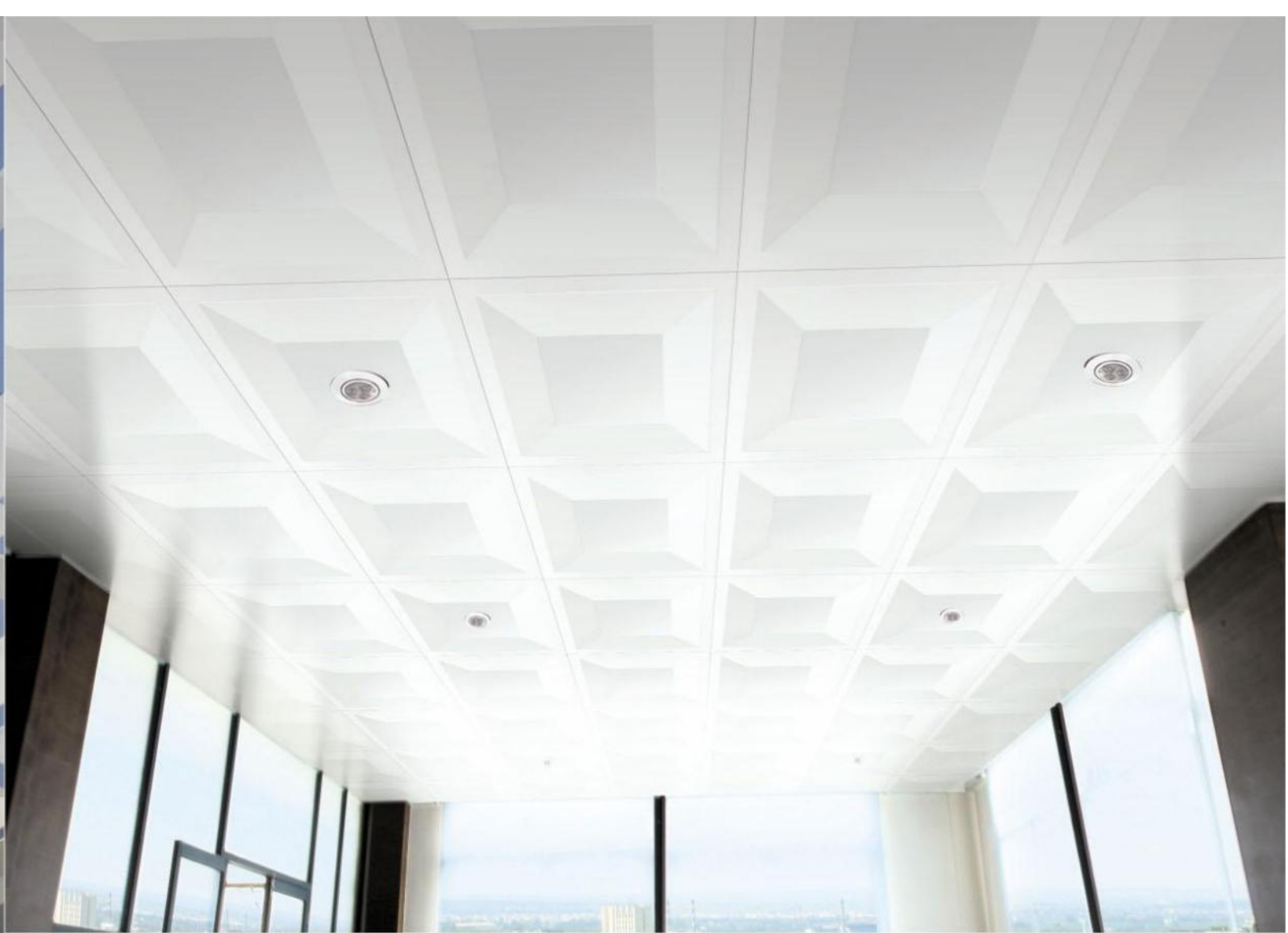

浅井型天花铺贴效果图

- 井型天花突破传统观念，采用井型设计，美观大方，立体感强，展示出灿烂缤纷的天花世界。井型顶部采用活板设计，可单独拆卸，并可单独喷成其他颜色，塑造出艺术风格的空间，把天花装饰效果推到极限的境界。
- 适用于商场、超市、加油站、地铁站、火车站、机场、长途汽车站、学校、体育场馆以及建筑物的大堂、走廊、卫生间等。
- Well-shaped ceilings break through the traditional ceiling concept by the application of a well shape that boasts graceful and elegant, and vivid 3D effect displaying diversified colorful ceiling patterns. Their movable panel designed on the top of the well not only can be separately detached, but also be painted into other colors so as to form an artistic space, which further upgrades the decorative function of the ceiling.
- Used in stopping,supermarket,gas stations,toll stations,subway,railway stations,airport,bus stations,schools,sport venues,and the lobbies,corridors,toilets of building.

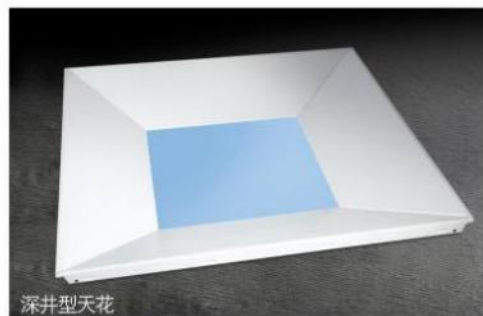

深井型天花

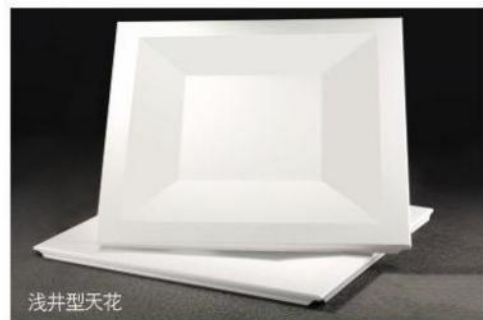

浅井型天花

### 井型天花结构图

Structure Diagram of Well-shaped Ceiling

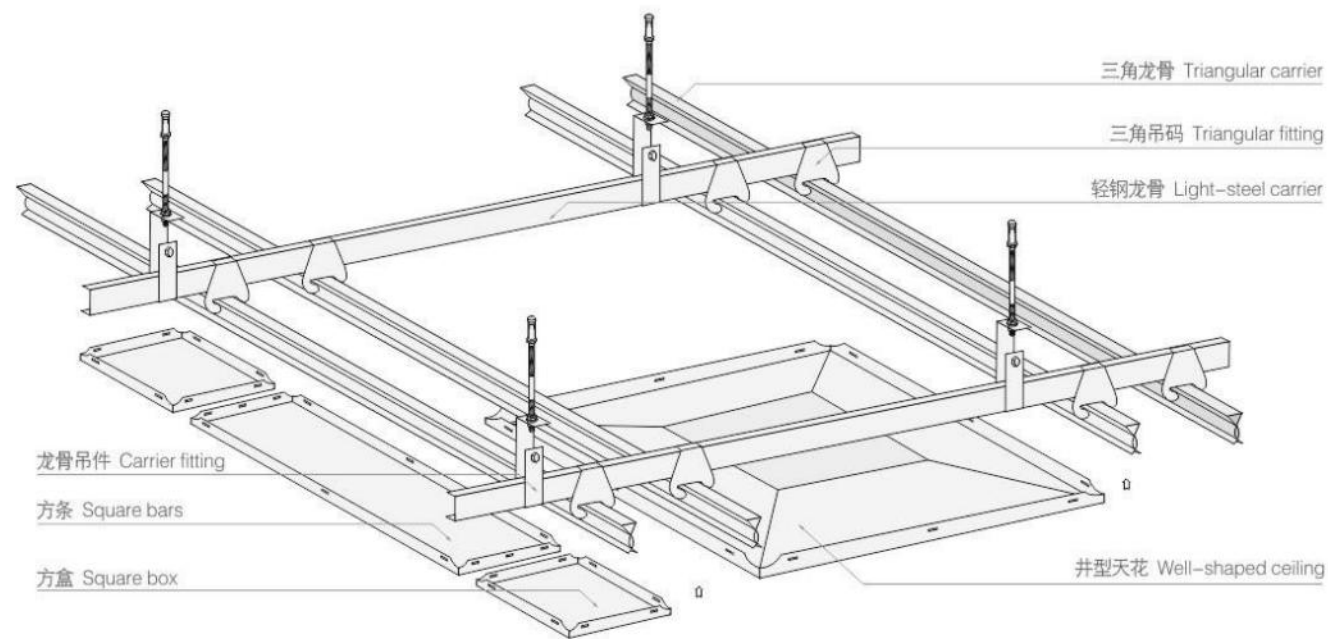

U-SHAPED  
SQUARE-GROOVE  
CEILING  
U型方槽

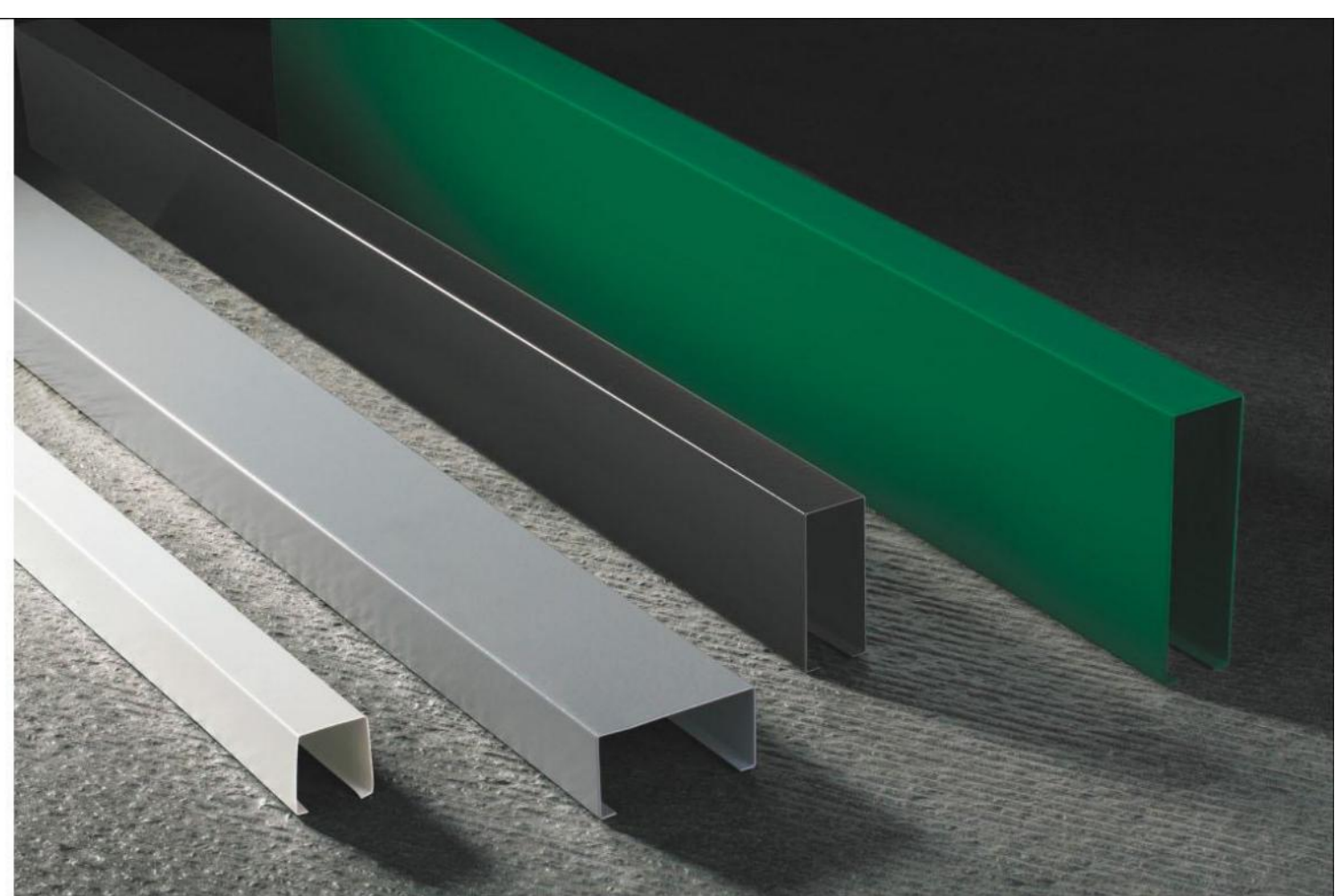

U型方槽安装结构图  
Structure Diagram of U-shaped  
Square-groove Ceiling

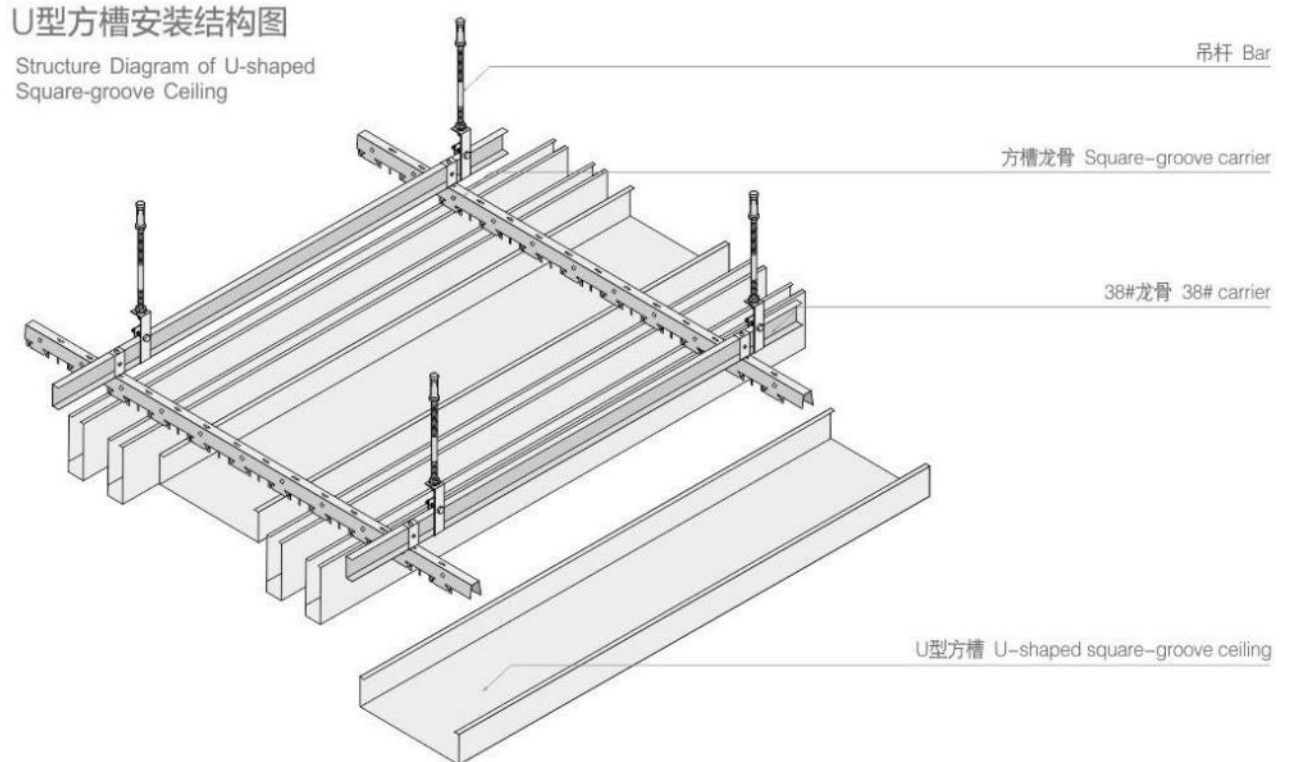

# U-SHAPED SQUARE-GROOVE CEILING

## U型方槽

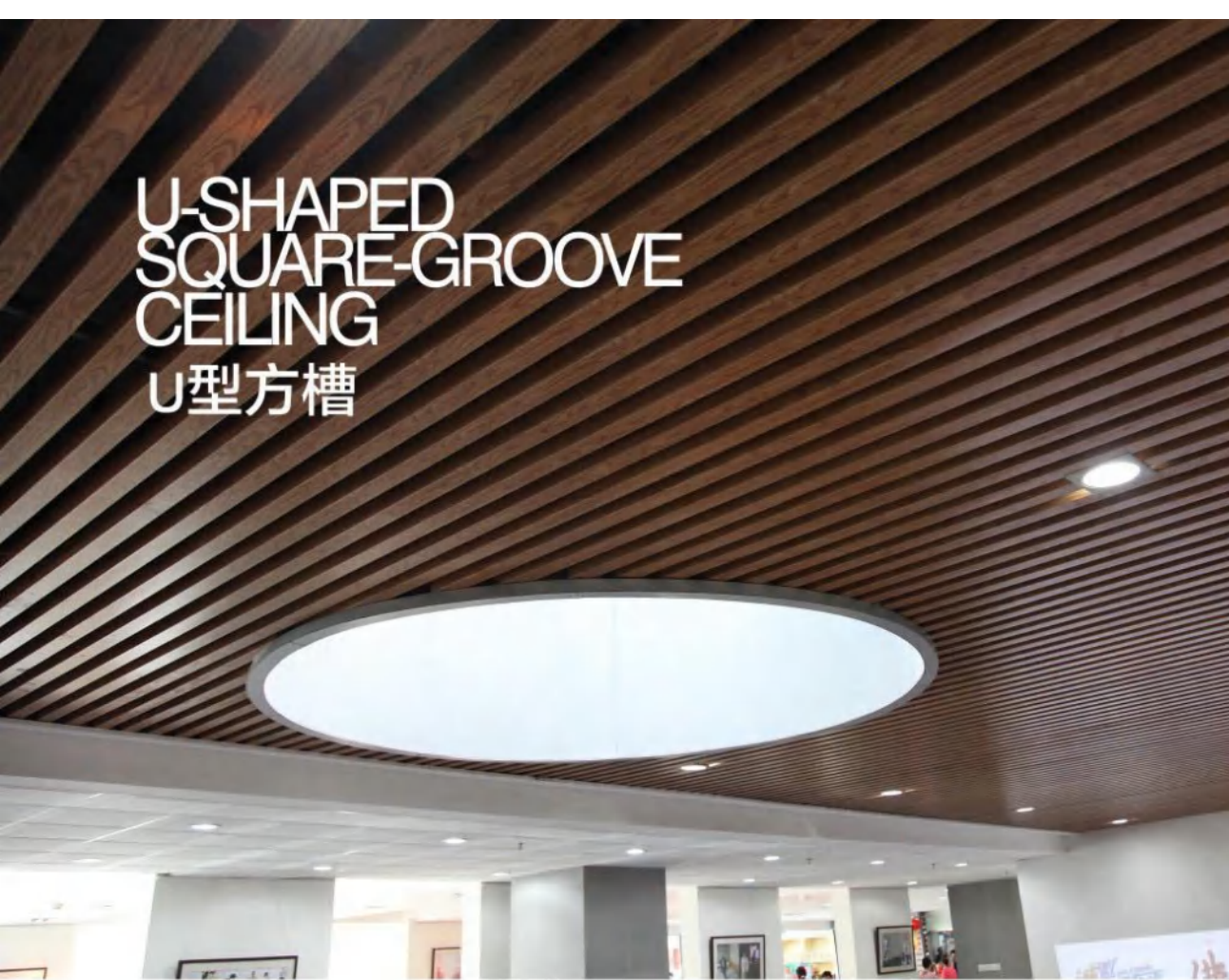

- U型方槽属于开放式空间，高度一致性，并排整齐，有利于通风设施和消防喷淋的布置安排，而不影响整体效果，也可与明架系统配合。U型方槽连接牢固，每件可重复多次装拆，易与各种灯具和装置相配，更方便设备维护。同时色泽均匀一致，在户内使用，质保10年不变色。

- 适用于走廊、酒吧、图书馆、会所、广场、会展、地铁站、机场、商场、写字楼等。

- U-Shaped square-groove belong to widen dyadic space and it's altitude is consistent, neatly side by side. The Arrangement that facilities beneficial to being ventilated,drenches with fighting fire gushing ventilated. And may coordinate with ridges system to use.U-Shaped square-groove connect solid,each document but many times linking up pretends to dismantle, easily various lamp and device match each other, conveniently maintain the equipment.At the same time,its' color and luster is homogeneously consistent ,put into use indoor can invariable in 10 years.

- Used in corridors, bars, libraries, clubs, squares, exhibition, subway, airports, shopping malls, office building and other places.

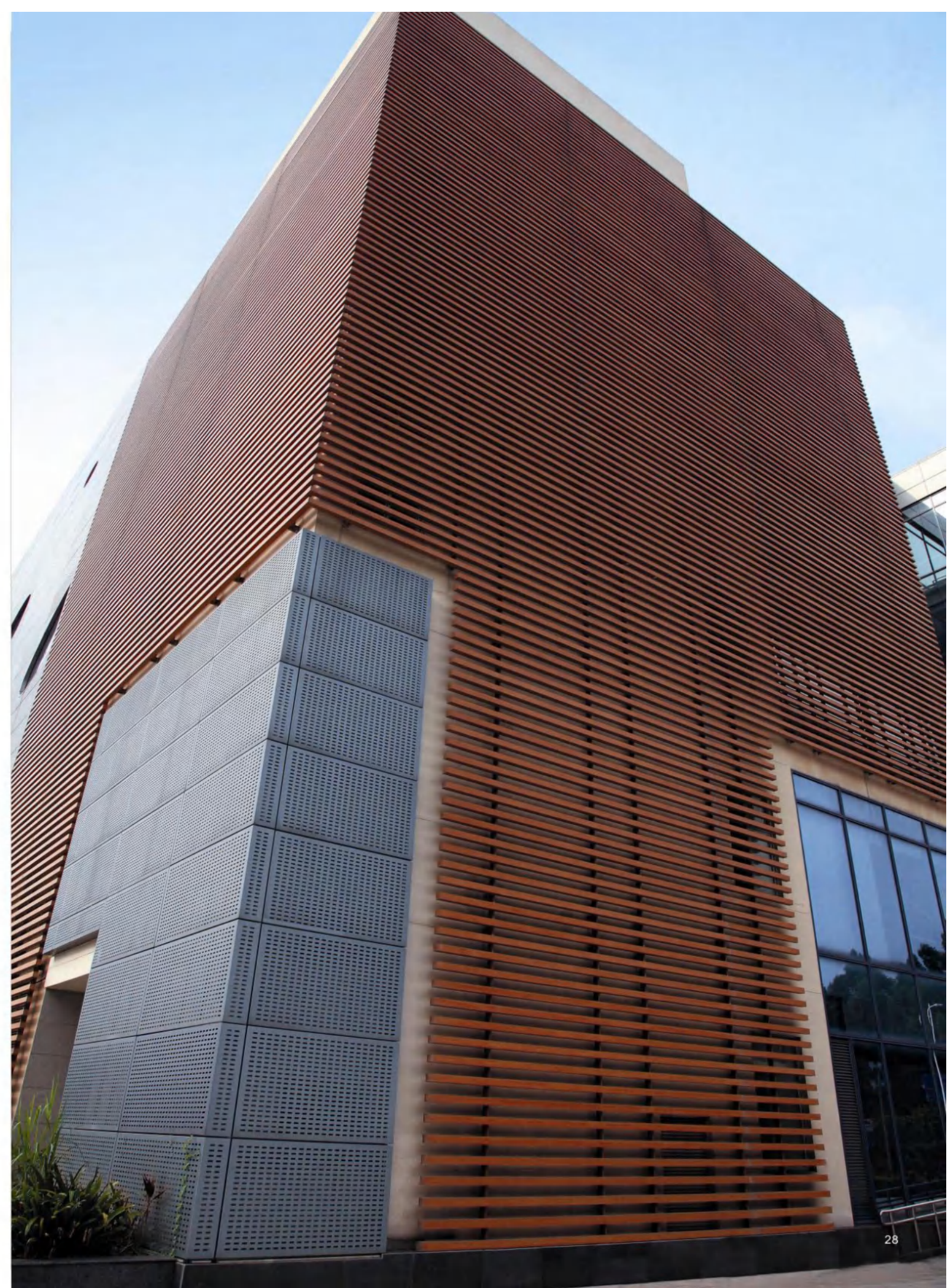

# ROUND TUBULAR CEILING 圆通天花

- 圆通是指圆梁装饰结构, 古朴典雅, 流线冲击效果, 可调节视觉差, 不影响喷淋, 安全性能佳, 无压抑感, 返璞归真、回归自然、雅俗共赏。
- 精铸而成, 精工打造, 搭配出独特的视觉效果; 开放式结构, 给人视野广阔感。
- Round tubular ceiling refers to the circular decoration structure, plain elegant, the streamline impact effect, may adjust the vision to be bad, does not affect sprays, the safety performance is good, does not have suppressive, gives up affectation, the return nature, appeal to both cultured and popular tastes.
- The essence casts becomes, exquisite making, match the unique visual effect, the open style structure, the field of vision is broad.

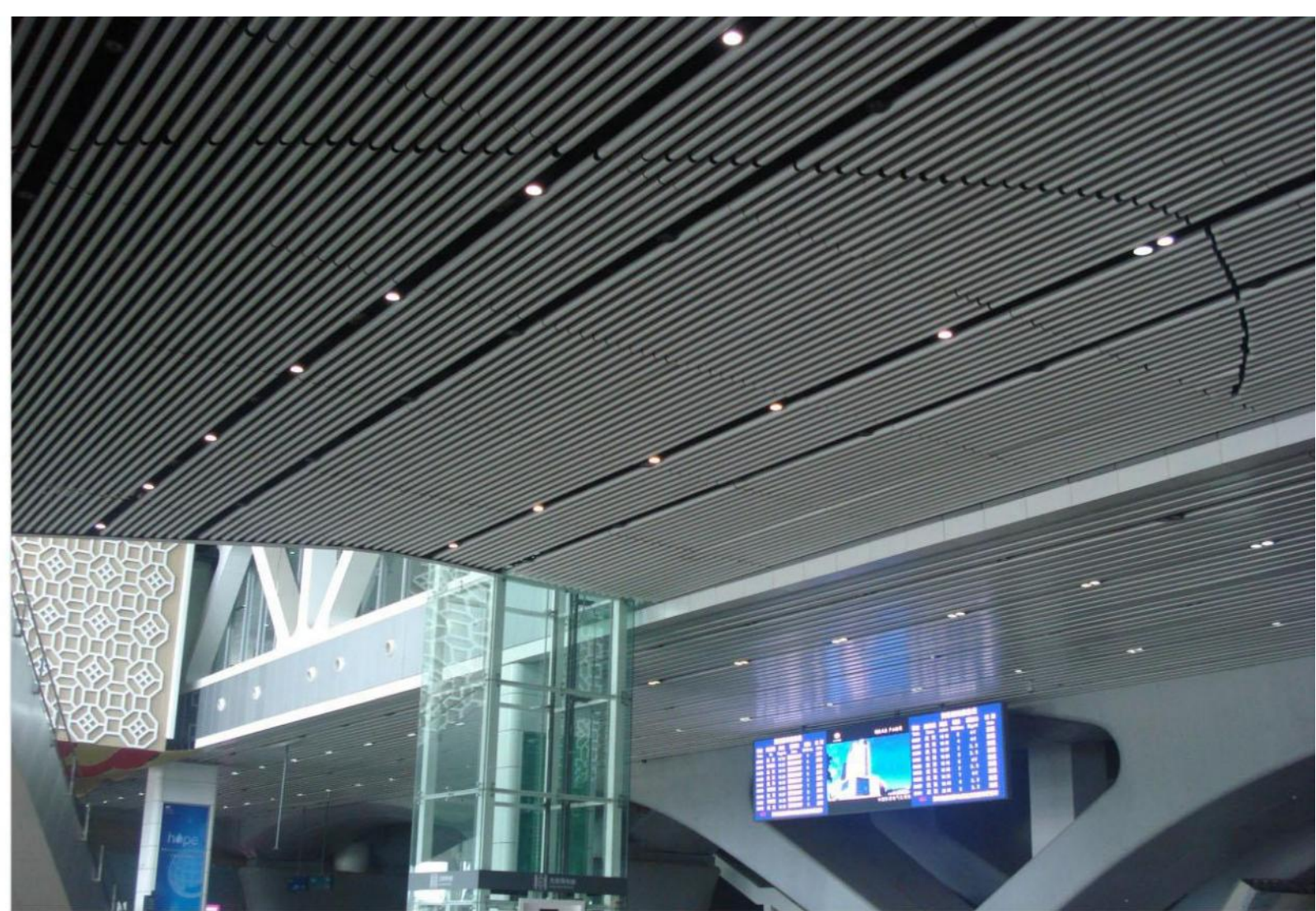

圆通天花安装结构图  
Structure Diagram of Round Tubular Ceiling

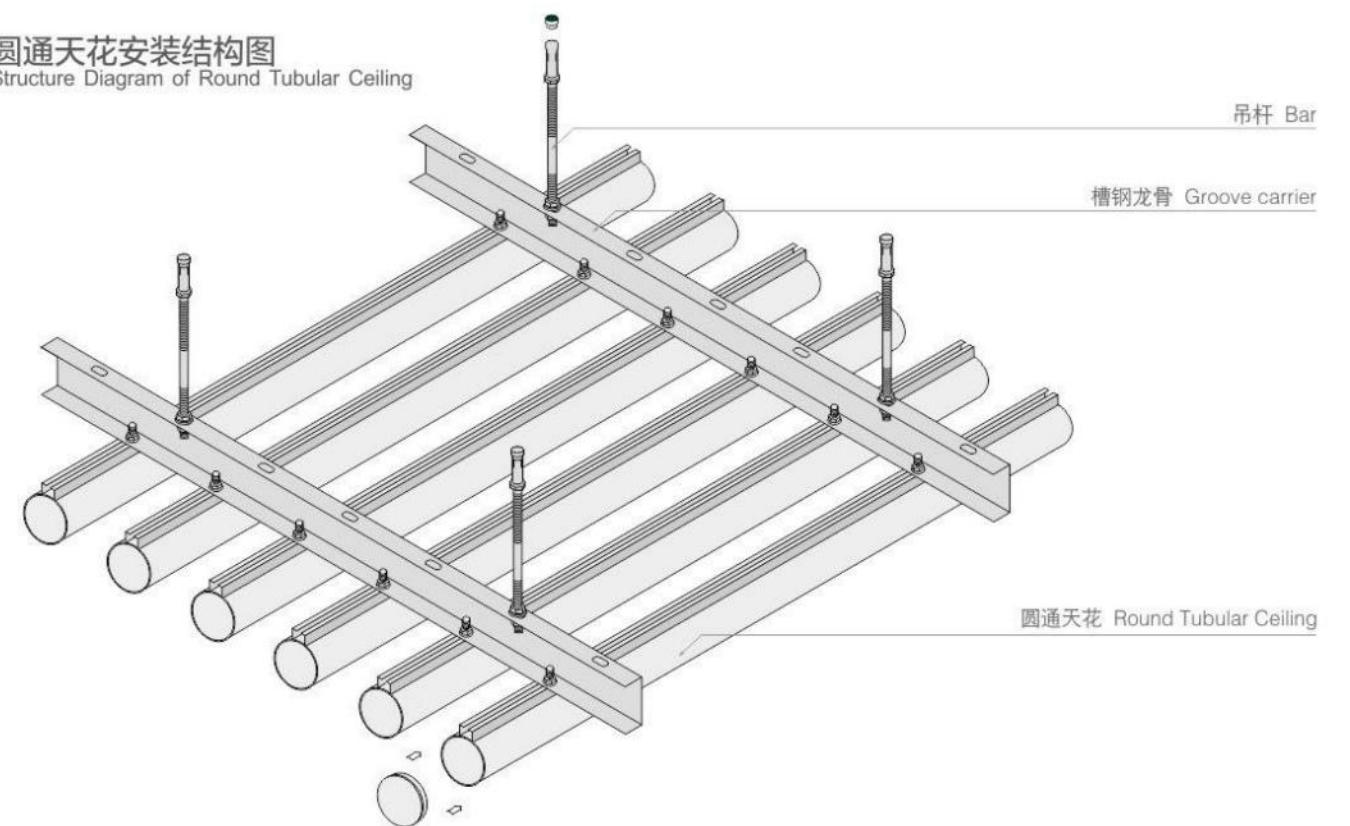



# GRID CEILING 格栅天花

适用于酒店、商场、商业建筑、行政楼房、超市等各种公共场所。  
Used in hotels, shopping malls, commercial buildings, administrative buildings, supermarkets and other public places.

7-shape  
Screen Ceiling  
7型挂片

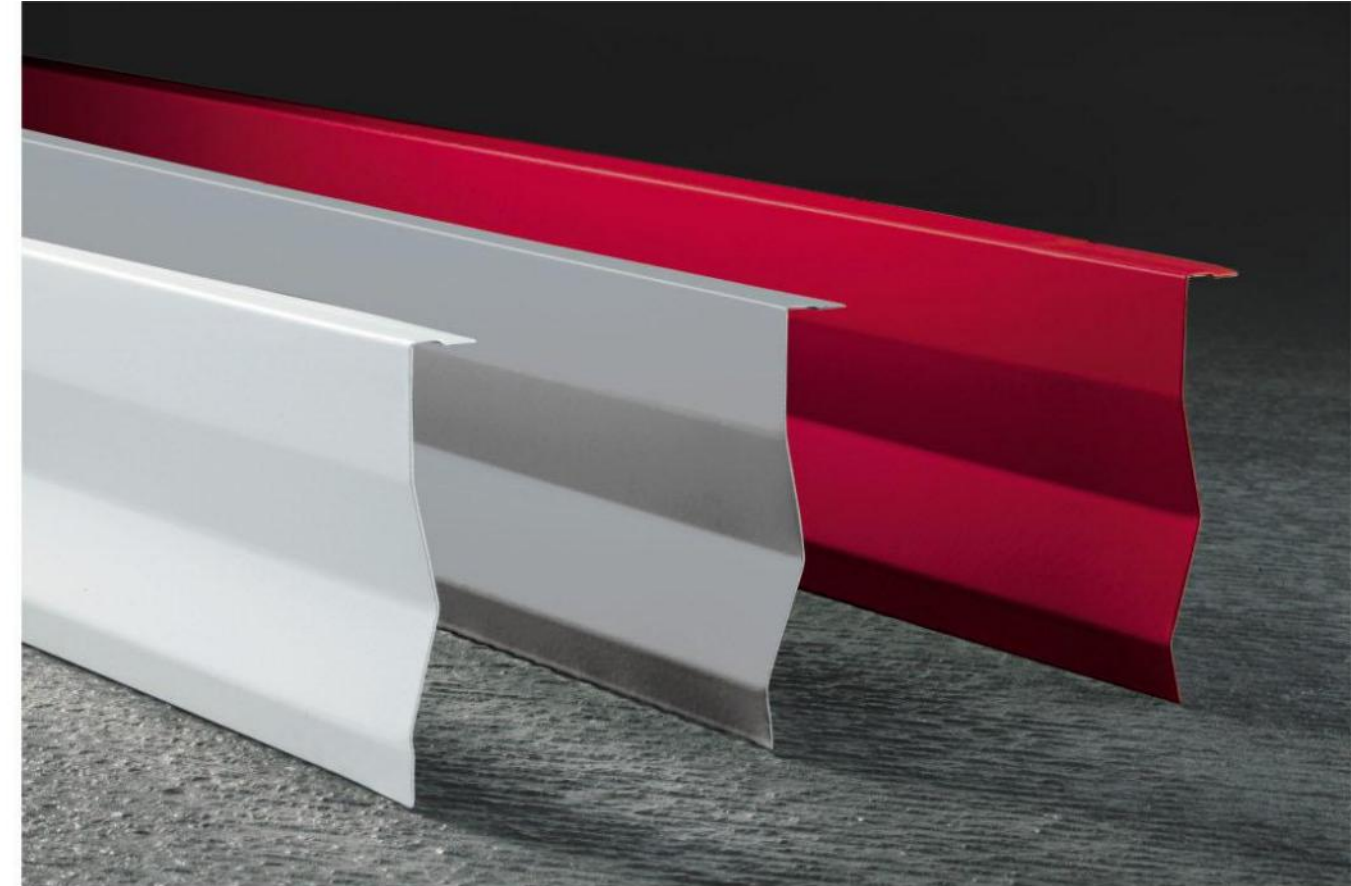

- 7型挂片天花采取单向条板安装，形成单向屏级视觉效果；产品外观线条明快飘逸，若采用适当的高度和视觉角度，能产生幕布效果；且维修限制较少，令设计变化万千，整个建筑空间宽敞通透。
- 适用于高级写字楼、办公室、走廊、机场、车站、厂房、医院、会所、银行、商场、展览馆等。

- 7-shaped screen ceiling, by way of the plate to form a one-way screen-level vision; bright and elegant lines, choose the appropriate height and viewing angle, which can produce curtain effect; its maintenance is less restrictive, so that thousands of design changes, the entire building room spacious and transparent.
- Used in office buildings, offices, corridors, airports, railway stations, factories, hospitals, clubs, banks, shopping malls, exhibition halls and so on.

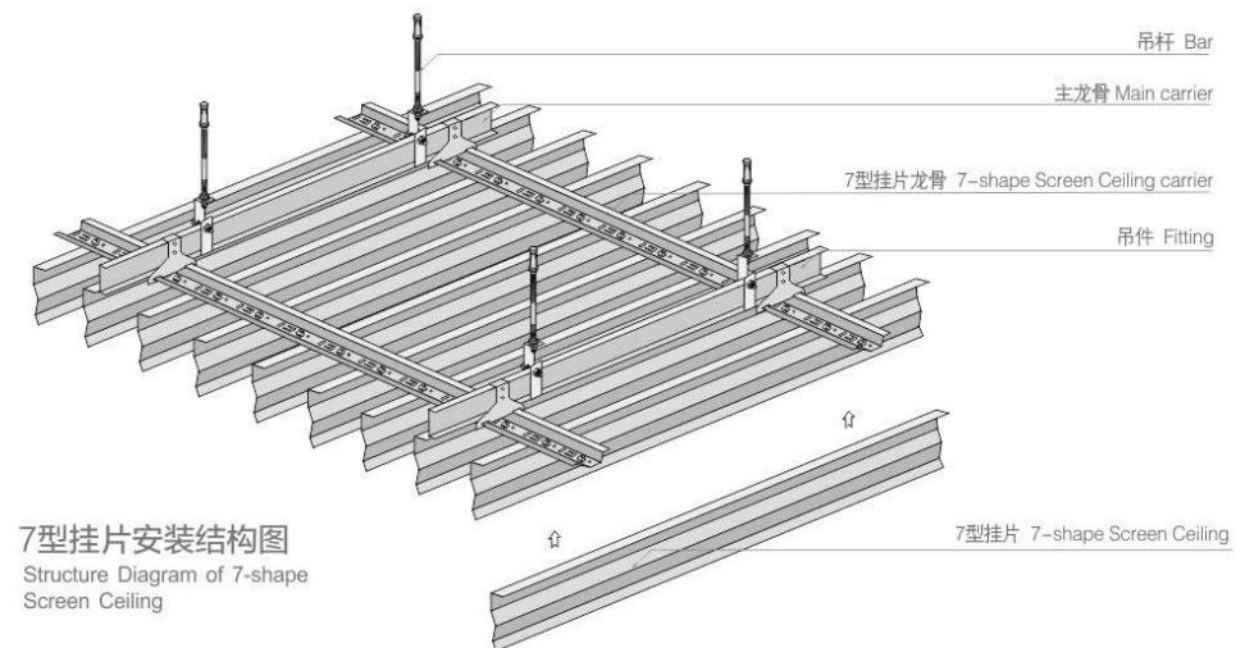

7型挂片安装结构图  
Structure Diagram of 7-shape  
Screen Ceiling

# OLECRANON SCREEN CEILING 鹰嘴挂片

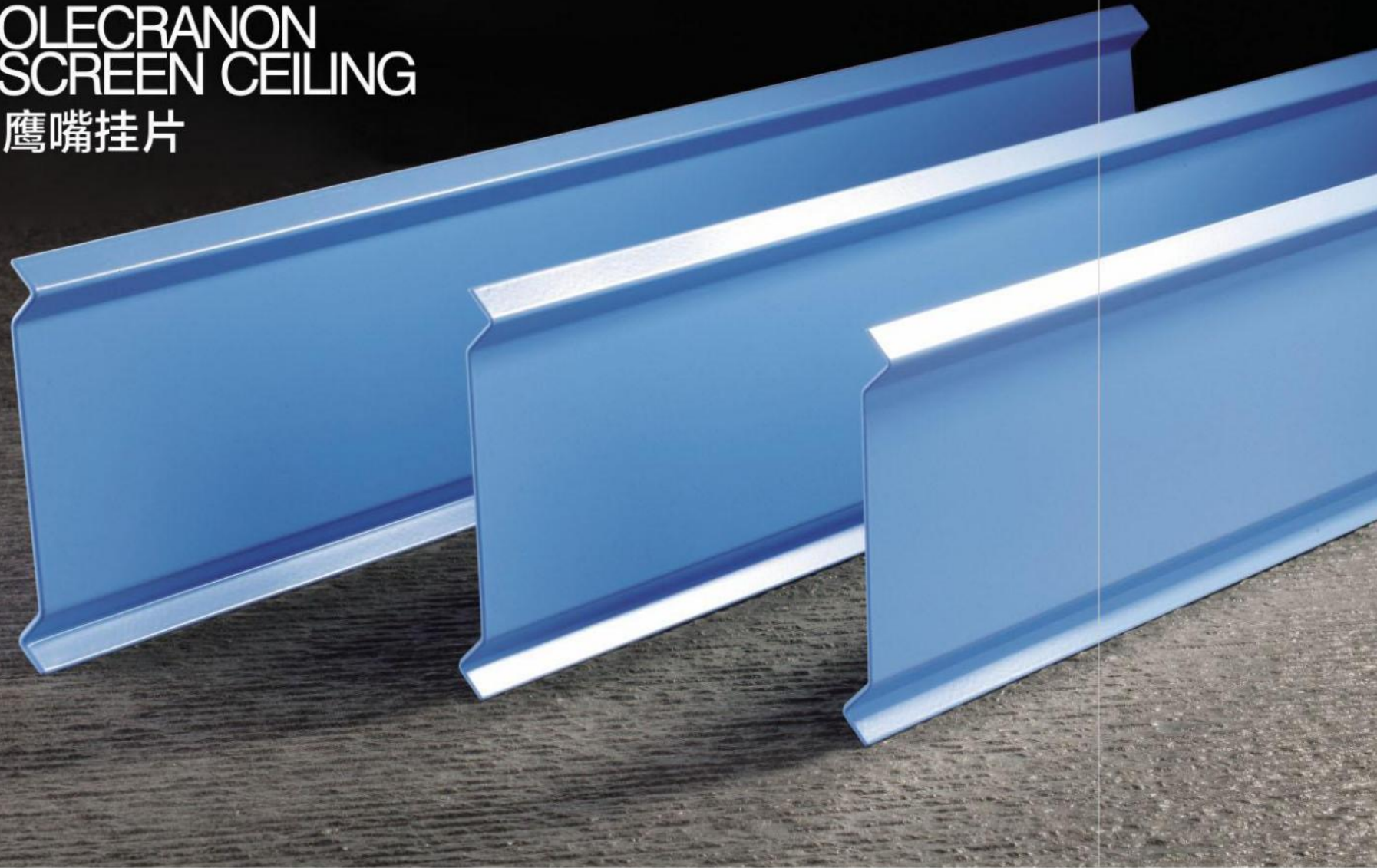

- 鹰嘴挂片采用铝合金平板或冲孔板经静电粉末喷涂而成，鹰嘴型结构给人以稳固牢靠的感觉，并具有防火、防潮、吸音功能，采用直插式安装法，具有任意装卸功能，非常方便楼顶的其它设施，如电线、水管、照明灯、消防等维修。
- 适用于各类大型公共建筑中的通道、机场、展览厅、购物中心、车站、隧道走廊等。

- It origins from aluminium alloy plates or punching plates, then coated by electrostatic powder coating, form right-angle structure. Olecranon-shape structure have security firm feeling.They are fireproof, moistureproof and sound-absorbing. It adopt straight cutting and freely to load and unload, convenient for maintain of wire, water pipe, lights and fire fighting device.
- Used to all kinds of large public buildings in the channel, airports, exhibition halls, shopping malls, station, tunnel corridors.

## 鹰嘴挂片安装结构图

Structure Diagram of Olecranon Screen Ceiling

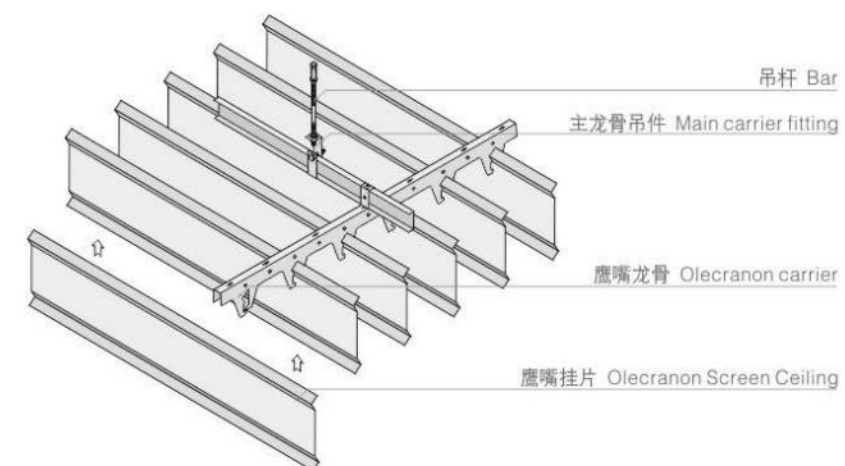

## 鹰嘴龙骨拼装示意图

The Drawing of Installation of Olecranon Carrier

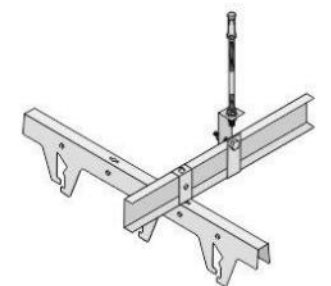

# C-SHAPED STRIP CEILING

## C型条扣

- C型条扣呈长条形分布,板面平整,拼缝细密,棱线分明,不同宽度可实现多种组合。整个吊顶系统整齐、大方、排列紧凑、视觉空间大,现代感强,且具有阻燃、防腐、防潮、装拆简便的优点。也可在穿孔板背面覆加一层吸音棉纸或黑色阻燃棉布,能够达到一定的吸声效果。
- 适用于商场、宾馆、写字楼、酒店、高级住宅等大中小型的建筑装饰。
- C-shaped strip elongated strip distribution,board formation ,patchwork close,ridge distinct,can achieve a variety of combination of different widths.The entire ceiling system neat,generous,compact arrangement ,perspective space,modern strong,and has a flame retardant, corrosion,moisture, the advantages of easy assembly and disassembly. Also can add a layer of perforated plate on the back cover or black flame-retardant cotton sound-absorbing tissue,the absorption can achieve certain results.
- Used in shopping malls,hotels,office building, senior housing and other large,middle and small architectural decoration.

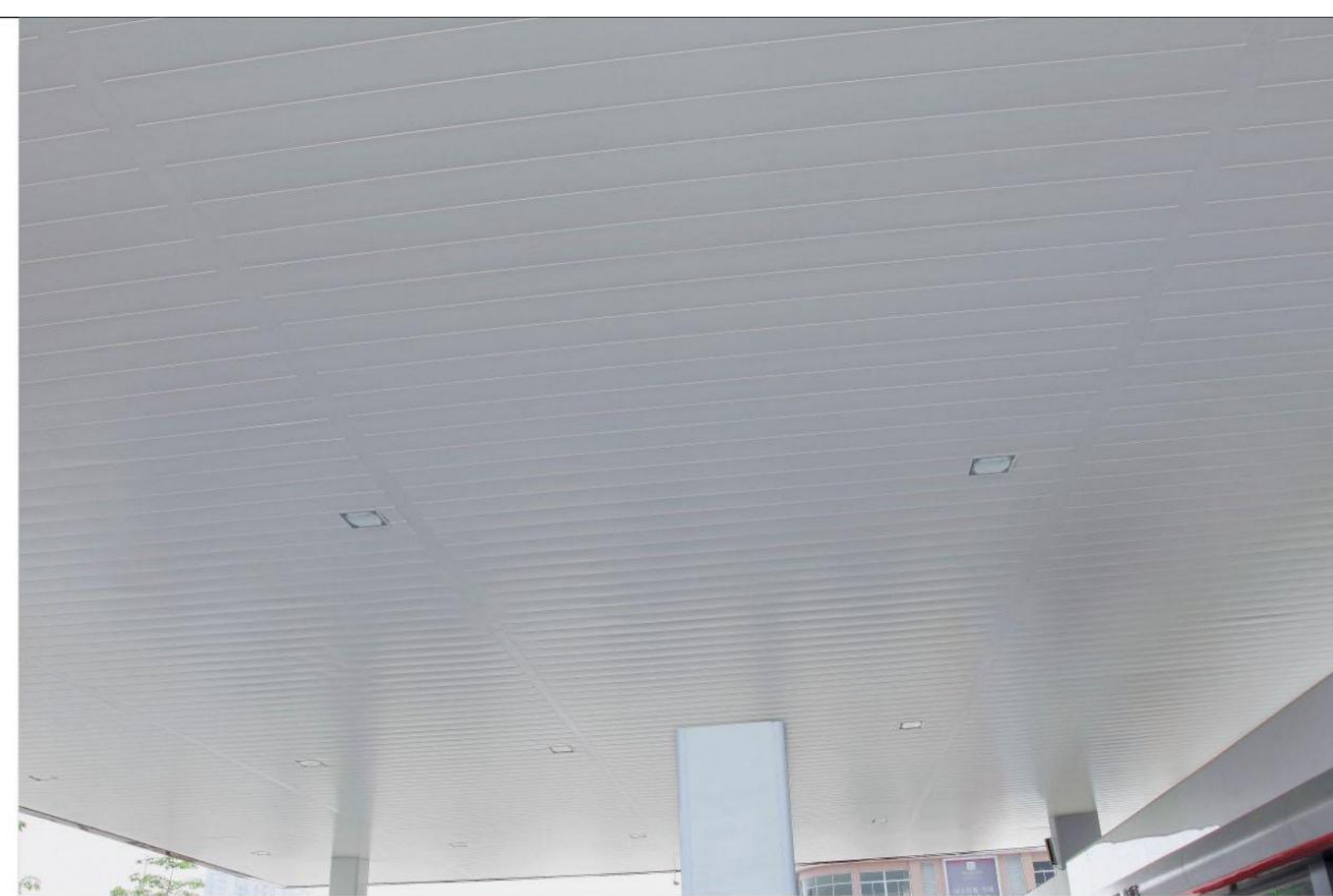
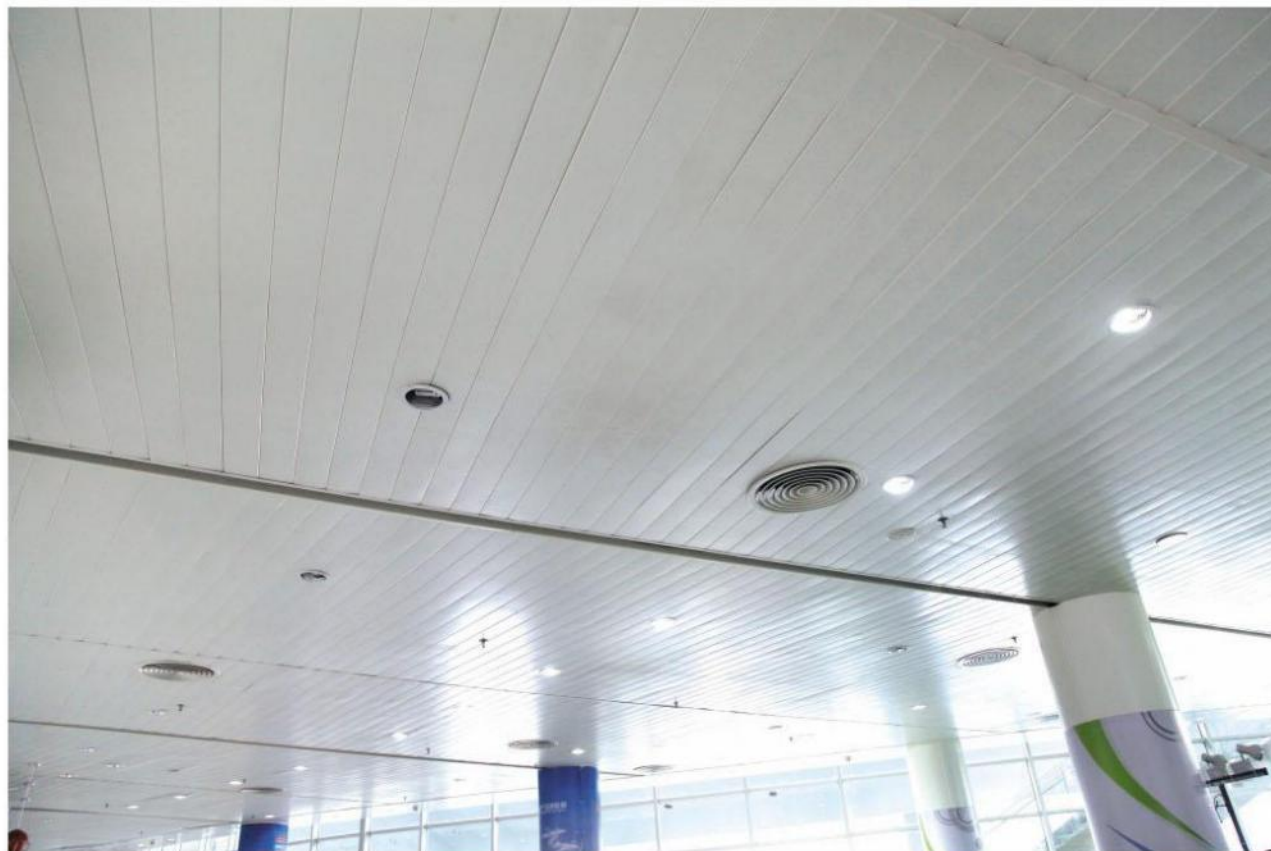

### C型条扣安装结构图

Structure Diagram of C-shaped Strip Ceiling

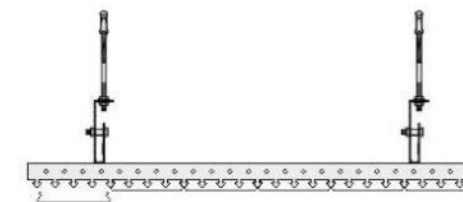

修边角拼装示意图  
The Drawing of Installation of Wall Edge Corner

C型条扣龙骨拼装示意图  
The Drawing of Installation of C-shaped Strip Carrier

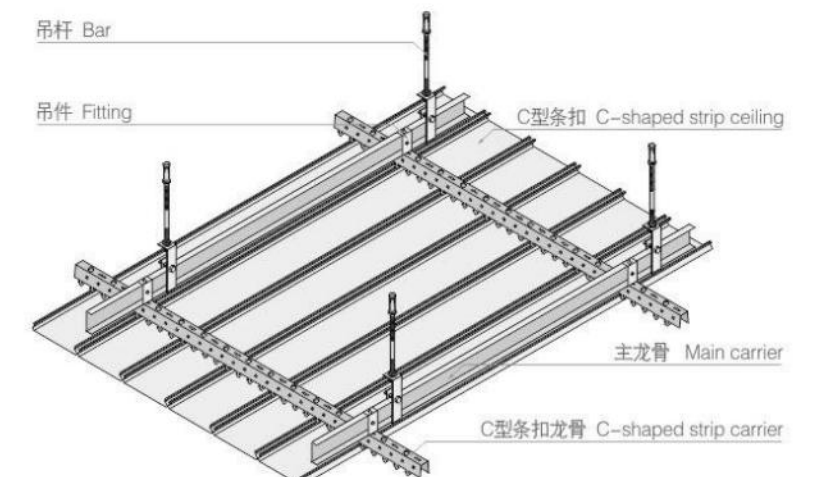
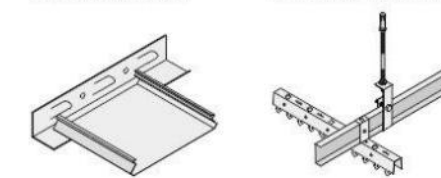

宽度(W) 75mm 100mm 150mm 200mm 300mm  
厚度(D) 0.6-1.0mm  
长度(L) 订尺  
高度(H) 15.5mm



C型条扣天花(直角)  
C-shaped strip ceiling(Right-angle)



C型条扣天花(斜角)  
C-shaped strip ceiling(Oblique-angle)

# S-SHAPED STRIP CEILING

## S型防风条扣

- S型条扣天花系列，严密的科学设计，美观大方。一方面让空间摆脱以往的单调，充分享受平面流线式的时尚，另一方面由于侧面特殊的防风设计，使得平滑密封的面板在一定程度上减少灰尘污垢的积聚和能量损耗。
- 适用于走廊、游泳池、加油站、车站、机场和户外装饰等防风性高的场所。
- S-shaped strip ceiling is generous and beautiful by strictly scientific designing. The space get rid of dull with the old panels, fully enjoy fashion of streamline, on the other hand, due to the special wind-resistant design of side face, the smooth and hermetic panel is able to reduce some dust, dirt and energy loss.
- Used in passageway, swimming pool, oil station, station, airport and outdoor decoration.



	直角	斜角
宽度(W)	300mm	300mm
厚度(D)	0.8-1.0mm	0.8-1.0mm
高度(H)	28mm 30mm	30mm
长度(L)	订尺	订尺

标准厚度 : 0.8mm Standard thickness: 0.8mm

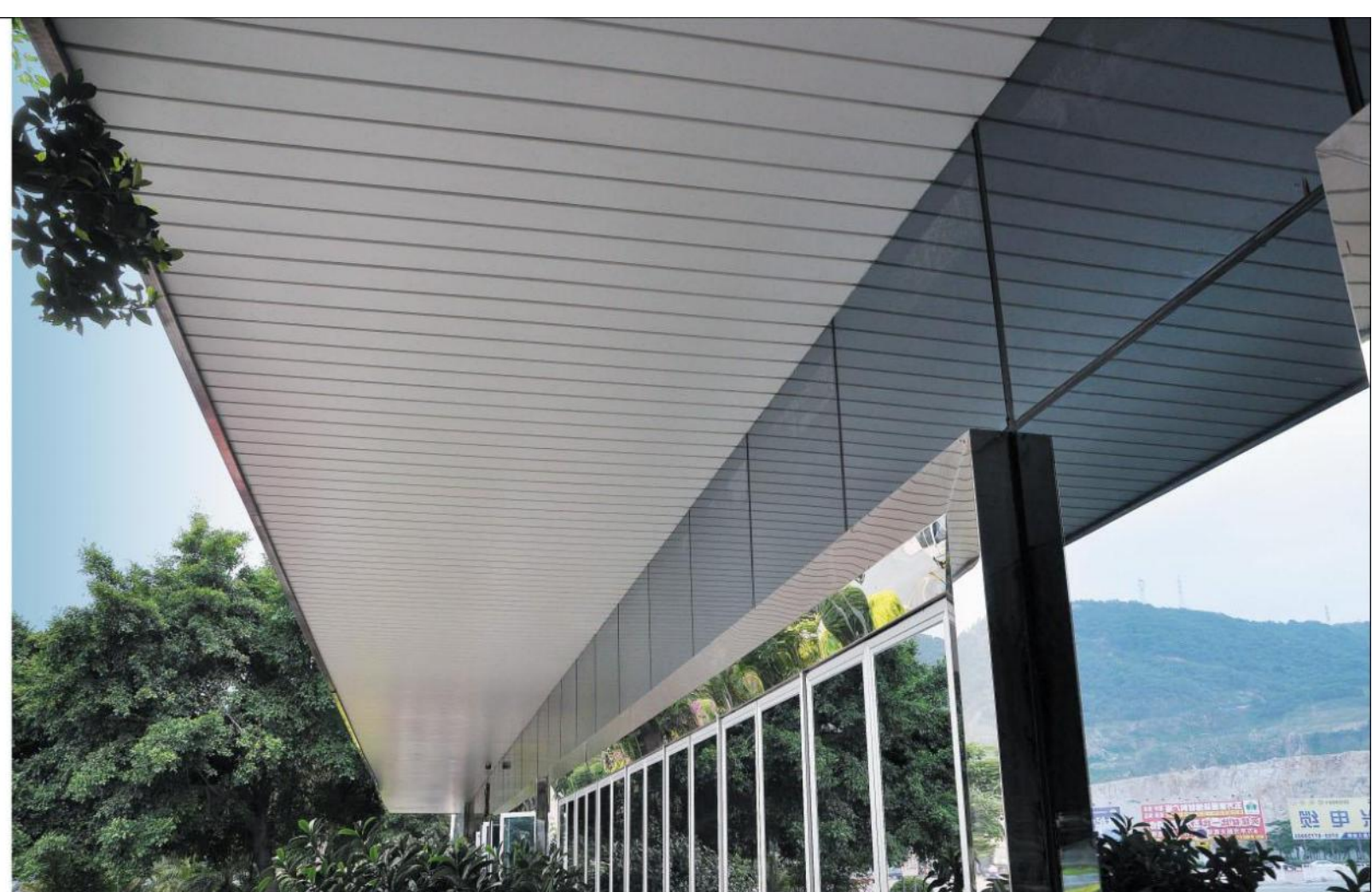

### S型条扣安装结构图

Structure Diagram of S-shaped Strip Ceiling

直角条扣拼装示意图

The Drawing of Installation of Right-angle Strip Ceiling

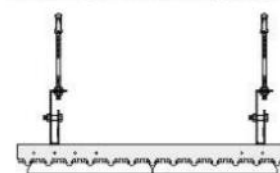

斜角条扣拼装示意图

The Drawing of Installation of Oblique-angle Strip Ceiling

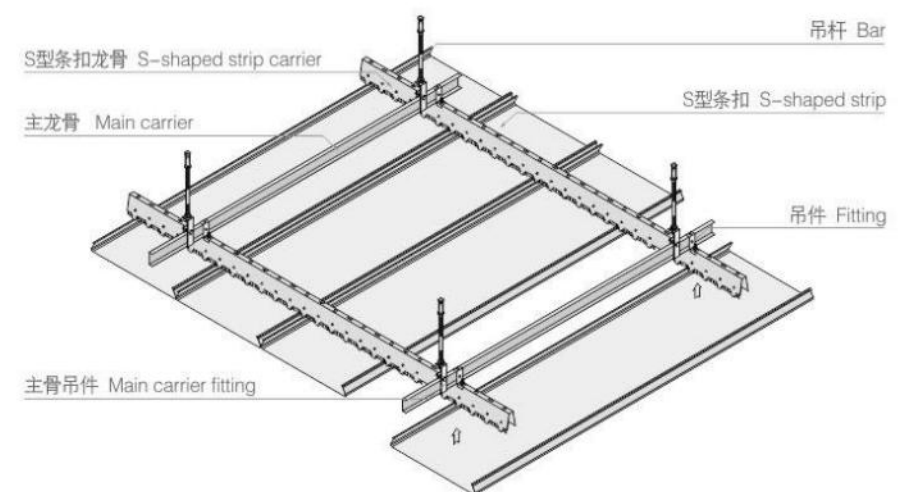
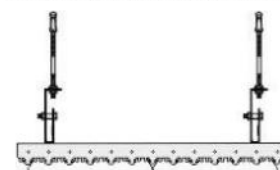

# G-SHAPED STRIP CEILING G型条扣

- G型天花板有别于传统的天花板，选用优质铝材，精密加工成型，并提供丰富的色彩选择，开放式吊顶营造出优美大方的造型和富于变化的色彩空间。
- 适用于商场、宾馆、写字楼、商贸娱乐场所、高级住宅等大中小型的建筑装饰。
- The G-shaped strip ceiling unlike the traditional smallpox, made of high quality aluminium, precision machining and molding. In the meantime, it offer a rich selection of color, open and generous ceiling to create a beautiful shape and varied color space.
- Used in shopping malls, hotels, office building, commercial bars, senior housing and other large, middle and small architectural decoration.



## G型条扣安装结构图

Structure Diagram of G-shaped Strip Ceiling

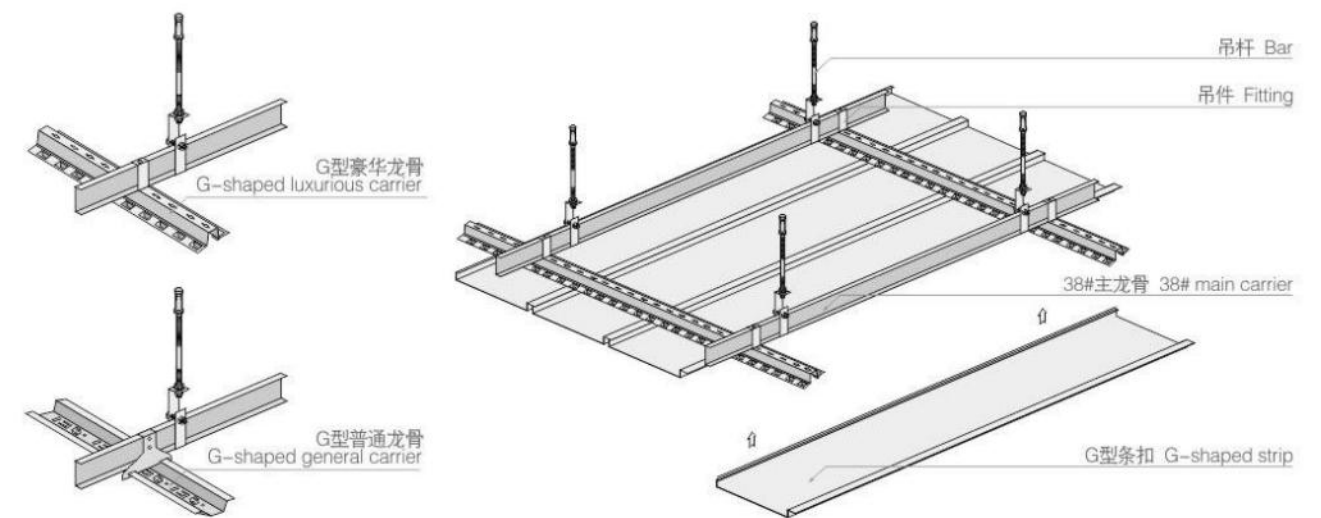

宽度(W)	100mm	150mm	200mm	300mm
厚度(D)	0.5-1.0mm			
高度(H)	11.5mm	15mm		
长度(L)	订尺			

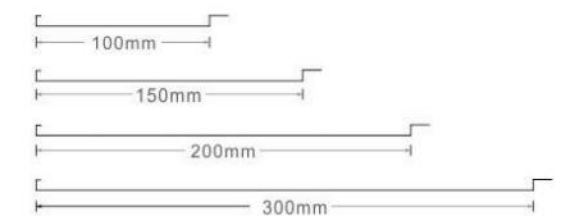

# FILM FACED SERIES 覆膜系列

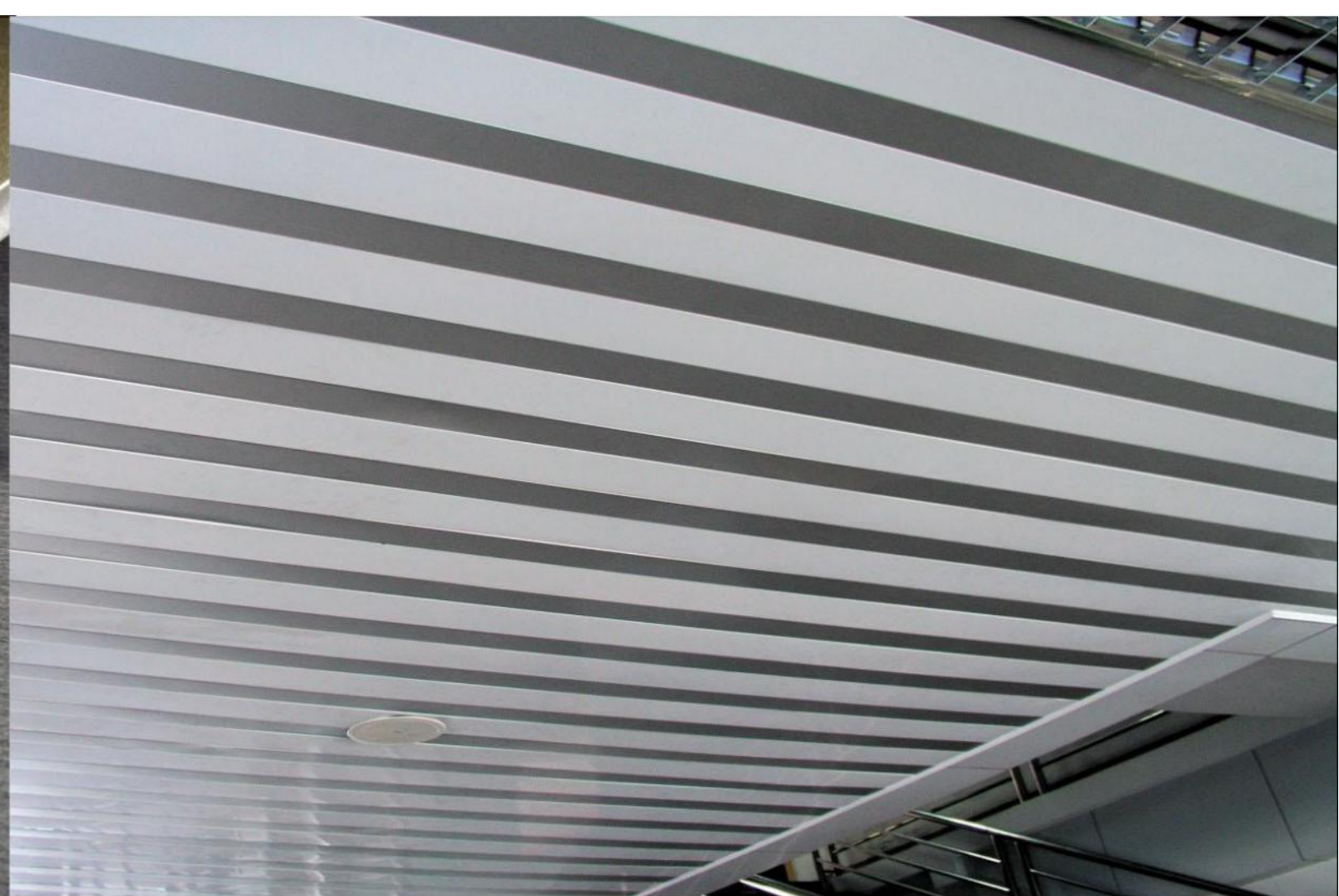
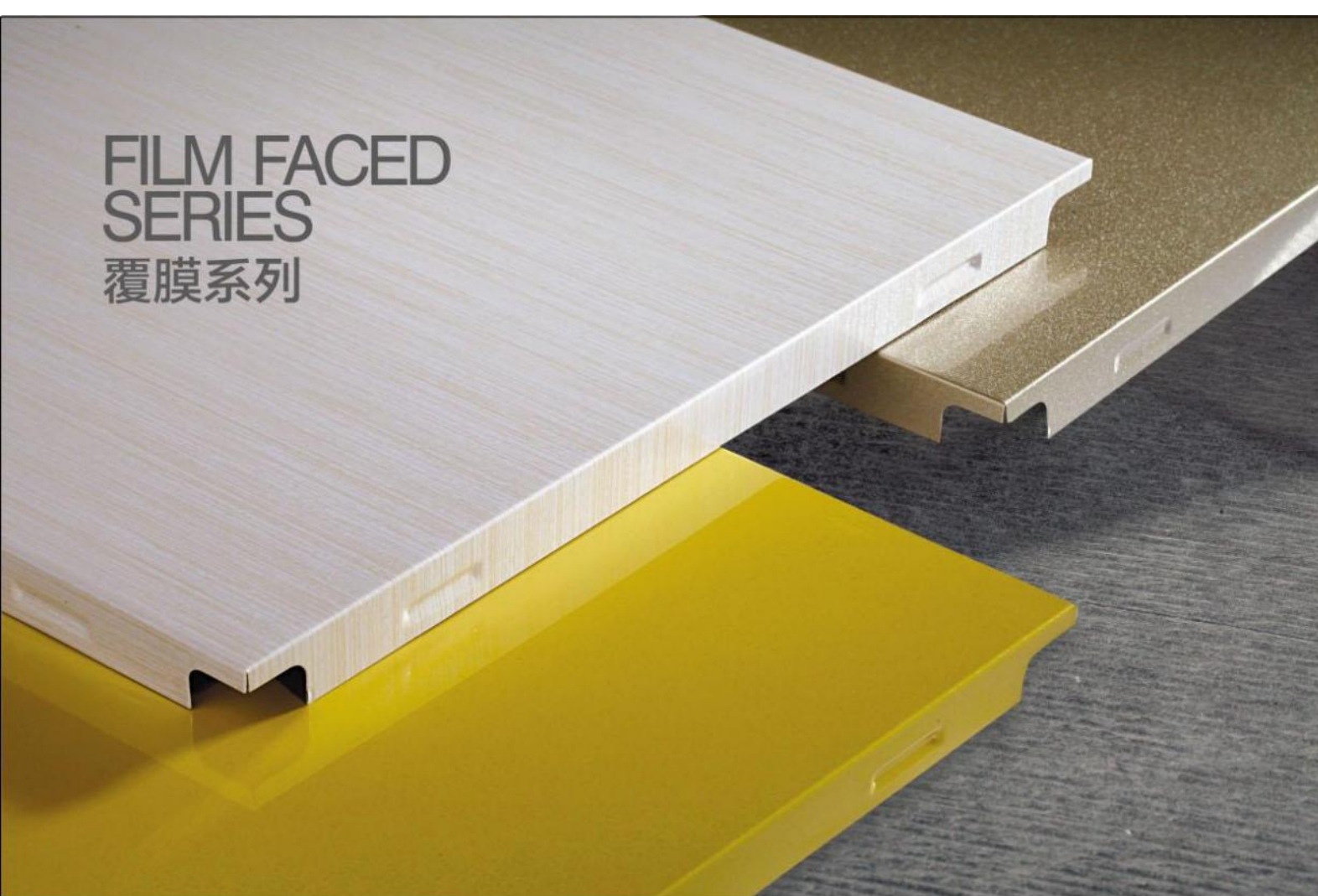

- 色彩亮丽的覆膜天花以彩漆金属板为基材，选用进口PVC高光膜、PET幻彩膜，在板面涂覆专用粘合剂复合而成。表面花纹色彩丰富不褪色，具有抗磨、抗冲击、防水、防火、清洗方便等优点，是当今时尚的装饰天花产品。而PVC高光膜具有丰富的柔韧性、光泽性以及色彩多样性，完全改变了金属天花表面单一的冷色调。
- 适用于机场、地铁站、写字楼、商业中心、宾馆、酒店、学院等大型建筑，更适用于家居中的卧室、客厅、厨房、卫生间、走廊等。
- Colorful films lamination ceiling is mainly made of color-painted metallic panel, and combined with imported PVC high-gloss film and PET magic colored film by using special adhesive. The ceiling with its multifunction of wear-proof, strike resistance, water-proof, fire resistance, being easy to clean, and fade-proof colorful surface has become a fashion in the field of decoration. PVC high-gloss film with its flexible and glossy characteristic and diversity color, has totally changed the single cold color of metallic panel surface.
- Used in airport, subway station, office, business center, hotel, college, and bedroom, living room, kitchen, bathroom, corridor and so on.



## 吸音系统 Sound Absorption System

- 金属天花产品能够有效解决噪音问题。当发出噪音之来源在指定的吸音范围内，噪音经过隔音物质后，产生摩擦，将声波能量转换成热能，从而减低声波值。在室外或室内的环境下，天花板冲孔形式及吸声材料的不同将影响它的吸声能力及特征。不同的冲孔模式及吸声材料成分，最终目的是为了迎合不同程度的吸声需求。
- “吸音”是指吸收大部分的声音，减少声波的反射。如图1所示，使用十分薄的吸声材料就可以达到相当好的隔音效果。
- 冲孔天花根据冲孔的排列构成多种图案，构图新颖，具有出色的消音降噪效果。如图2所示，在贴无纺布的基础上再加贴40mm厚的玻璃纤维，会有更好的消音降噪效果。
- Metal acoustic ceilings are artificial functional acoustic solutions. Noise is absorbed when the sounds are directed to specific zones, thus, the characteristics of the metal panel to influence the acoustic ability and feature in an indoors pace, in order to meet any specific expectations.
- For sound absorption, the propagation of sounds is absorbed by converting sound energy into thermal energy. Materials with sound-absorbing properties are called sound-absorbing materials. Be shown in Fig. 1
- In practice, perforated ceiling made of metal, wood, plastic or gypsum and provided with a porous sound-absorbing materia l(thickness is 40mm) on the back are used for absorption of air-borne noises. Be shown in Fig. 2

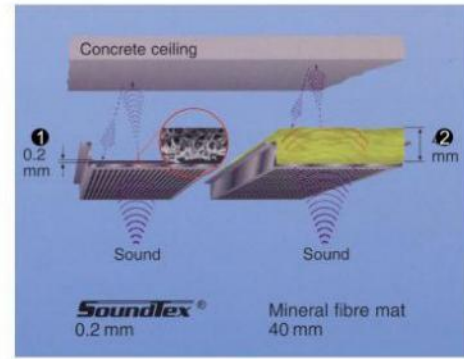

声音在吸音材料上的能量转换过程  
The transformation process of sound, which is on sound-absorbing materials.



SoundTex吸音无纺布材料可直接贴在天花板上  
SoundTex sound-absorbing nonwovens can be mounted without difficulty into ceiling systems.



## 吸音无纺布 Sound-absorbing Nonwovens

- SoundTex吸音无纺布能够使穿孔天花的声阻抗降低到与空气的阻抗相同的水平。迫使声波穿过无纺布结构，产生摩擦，这种摩擦造成动能损失，从而降低声波值。SoundTex超薄的外形设计使加工和安装极为简便。可在工厂直接粘贴在天花板上，节约了运输费用，也降低了工程现场的工作量。
- SoundTex sound-absorbing nonwovens is a sound dissipation and can be achieved by means of very thin absorbers presenting an appropriate sound impedance. A porous sound-absorbing material is our acoustic nonwoven SoundTex. On porous sound-absorbing materials, sound energy is mainly converted into thermal energy by viscous friction between the oscillating particles of the sound-propagating medium (air) and the structure of the porous material.

## 吸音系数 Coefficient of sound absorption

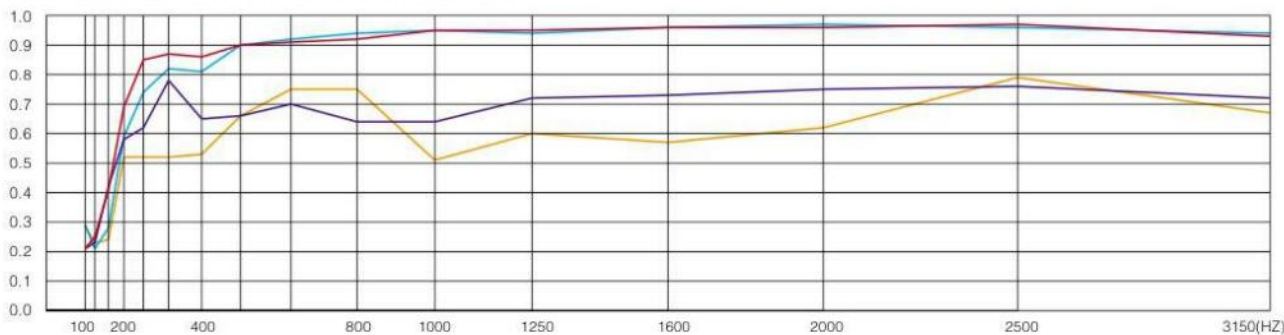

- ∅2.5 贴无纺布
- ∅2.5 贴无纺布，再加40mm厚玻璃棉
- ∅1.8 贴无纺布
- ∅1.8 贴无纺布，再加40mm玻璃棉

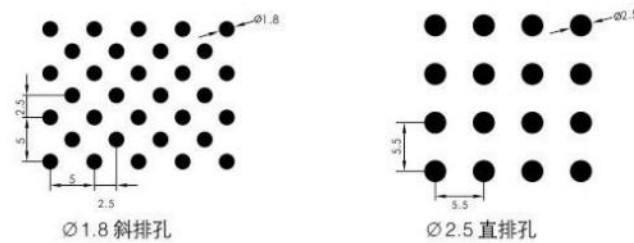

∅1.8 斜穿孔

∅2.5 直穿孔

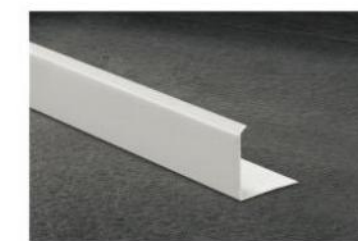
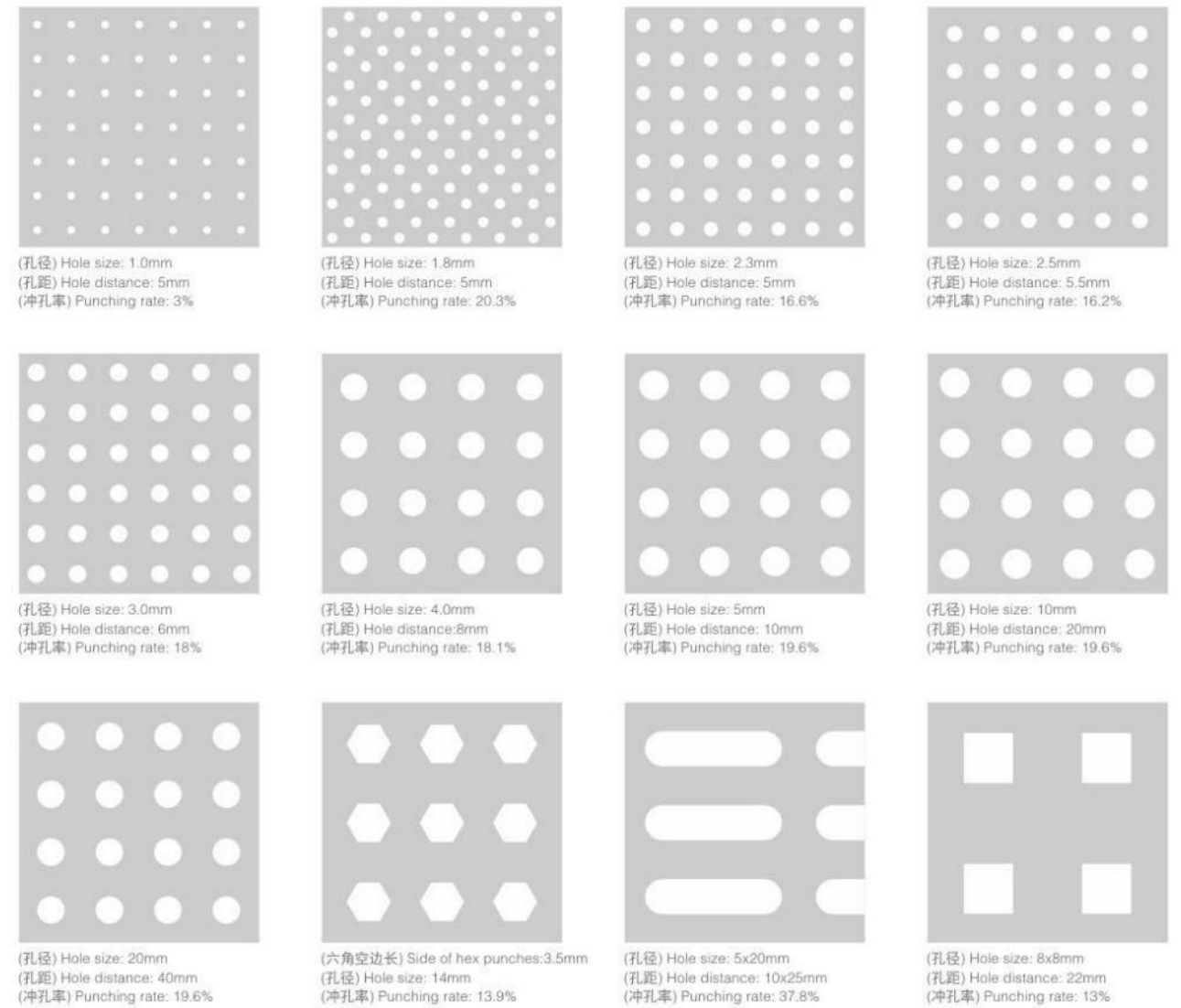

斜边修边角 25x25mm  
Bevel side revised corner

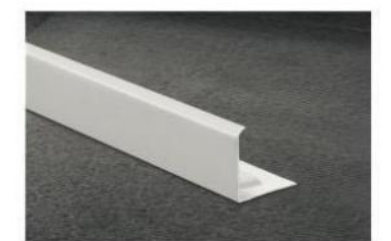

斜边冲孔修边角 25x25mm  
Bevel side punching revised corner



直角修边角 25x25mm  
Right angle revised corner



木线修边角 25x25mm  
Wood line revised corner



木线冲孔修边角 30x25mm  
Wood line punching revised corner

# Square Plate Punching Fancy

## 方板冲孔花式

### 吸音孔示意图 Drawing of Sound Absorbing Hole

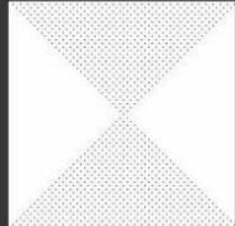
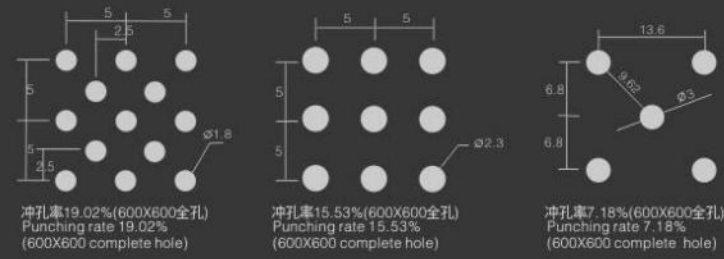

品名: Ø3对角冲孔铝方板  
编号: YC6001  
Description: diagonal punching aluminium square plate  
Code: YC6001

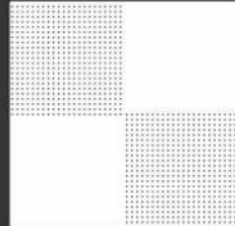

品名: Ø3正方对角冲孔铝方板  
编号: YC6002  
Description: quadrant diagonal punching aluminium square plate  
Code: YC6002

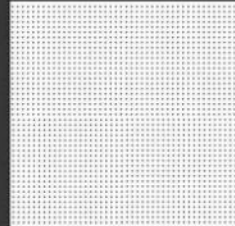

品名: Ø3全冲孔铝方板  
编号: YC6003  
Description: full-punching aluminium square plate  
Code: YC6003



品名: 平面铝方板  
编号: YC6004  
Description: flat aluminium square plate  
Code: YC6004

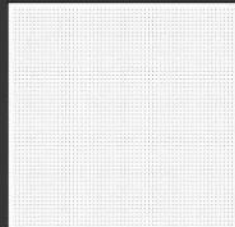

品名: Ø2.2全冲孔铝方板  
编号: YC6005  
Description: full-punching aluminium square plate  
Code: YC6005

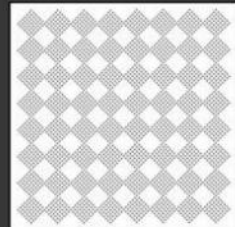

品名: Ø3 49格拼花冲孔铝方板  
编号: YC6006  
Description: 49-grid match punching aluminium square plate  
Code: YC6006



品名: Ø3对角拼花冲孔铝方板  
编号: YC6007  
Description: diagonal match punching aluminium square plate  
Code: YC6007



品名: Ø3对角拼花冲孔铝方板  
编号: YC6008  
Description: diagonal match punching aluminium square plate  
Code: YC6008

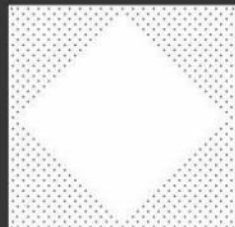

品名: Ø3菱形边冲孔铝方板  
编号: YC6010  
Description: prism side punching aluminium square plate  
Code: YC6010

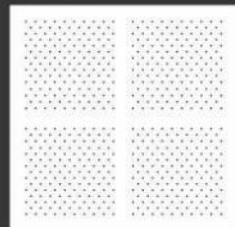

品名: Ø3正方四角冲孔铝方板  
编号: YC6012  
Description: quadrant four-corner punching aluminium square plate  
Code: YC6012



品名: Ø3菱形冲孔拼花铝方板  
编号: YC6014  
Description: prism punching match aluminium square plate  
Code: YC6014



品名: #型铝方板  
编号: YC6018  
Description: #-shape aluminium square plate  
Code: YC6018



品名: Ø3#型四边冲孔铝方板  
编号: YC6019  
Description: #-shape four-side punching aluminium square plate  
Code: YC6019

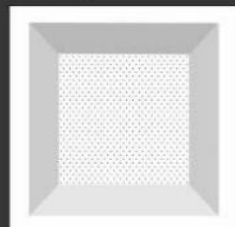

品名: Ø3#型中间冲孔铝方板  
编号: YC6020  
Description: #-shape middle punching aluminium square plate  
Code: YC6020

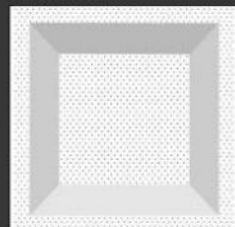

品名: Ø3#型冲孔铝方板  
编号: YC6021  
Description: #-shape punching aluminium square plate  
Code: YC6021

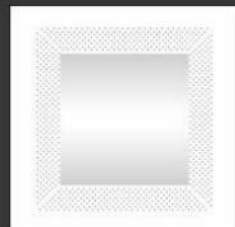

品名: Ø3斜边冲孔铝方板  
编号: YC6022  
Description: #-shape hypotenuse punching aluminium square plate  
Code: YC6022



品名: Ø3四角花冲孔铝方板  
编号: YC6033  
Description: four-corner-flower punching aluminium square plate  
Code: YC6033

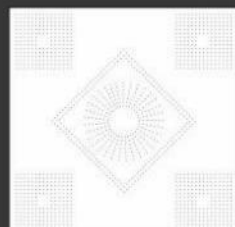

品名: Ø3冲孔拼花铝方板  
编号: YC6036  
Description: daisy punching aluminium square plate  
Code: YC6036

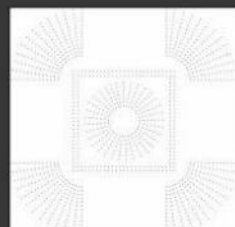

品名: Ø3太阳花冲孔铝方板A  
编号: YC6039  
Description: daisy punching aluminium square plate A  
Code: YC6039



品名: Ø3太阳花冲孔铝方板B  
编号: YC6040  
Description: daisy punching aluminium square plate B  
Code: YC6040

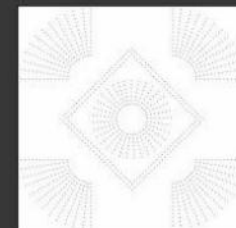

品名: Ø3太阳花冲孔铝方板C  
编号: YC6041  
Description: daisy punching aluminium square plate C  
Code: YC6041



品名: Ø3太阳花冲孔铝方板D  
编号: YC6042  
Description: daisy punching aluminium square plate D  
Code: YC6042

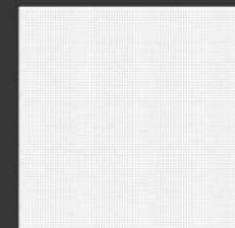

品名: Ø1.8全冲孔铝方板  
编号: YC6043  
Description: full-punching aluminium square plate  
Code: YC6043

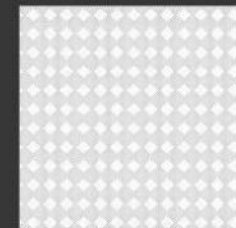

品名: Ø1.8大方格冲孔铝方板  
编号: YC6044  
Description: big-check punching aluminium square plate  
Code: YC6044

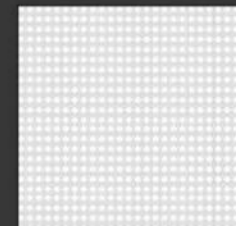

品名: Ø1.8中方格冲孔铝方板  
编号: YC6045  
Description: medium-check punching aluminium square plate  
Code: YC6045

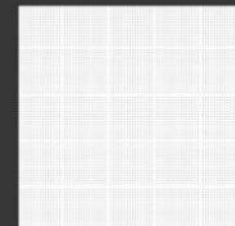

品名: Ø1.8冲孔25格铝方板  
编号: YC6046  
Description: punching 25-grid aluminium square plate  
Code: YC6046

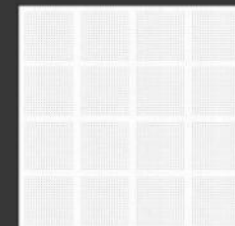

品名: Ø1.8冲孔16格铝方板  
编号: YC6047  
Description: punching 16-grid aluminium square plate  
Code: YC6047



品名: Ø3冲孔拼花铝方板  
编号: YC6051  
Description: punching match aluminium square plate  
Code: YC6051

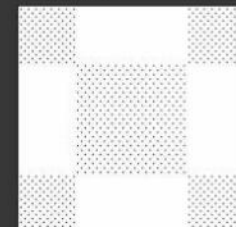

品名: Ø3冲孔拼花铝方板  
编号: YC6052  
Description: punching match aluminium square plate  
Code: YC6052



一号云



二号云



三号云

蓝天白云实景图 600x600, 300x300均可选择以上图案  
The actual picture of blue sky and white cloud, the above pictures are available for 600x600 and 300x300

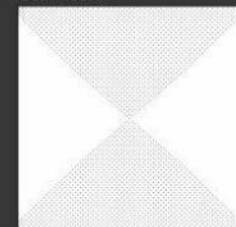

品名: Ø3对角冲孔拼花铝方板  
编号: YC3001  
Description: diagonal punching aluminium square plate  
Code: YC3001

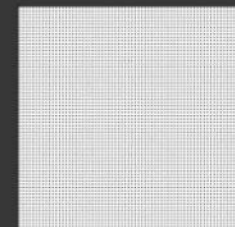

品名: Ø3全冲孔铝方板  
编号: YC3002  
Description: full-punching aluminium square plate  
Code: YC3002

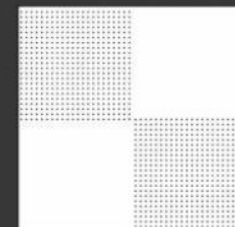

品名: Ø3正方对角铝方板  
编号: YC3003  
Description: quadrant diagonal punching aluminium square plate  
Code: YC3003

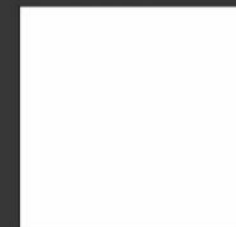

品名: 平面铝方板  
编号: YC3004  
Description: flat aluminium square plate  
Code: YC3004

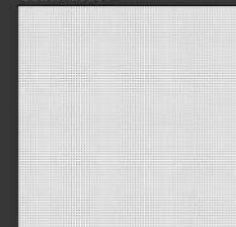

品名: Ø1.8全冲孔铝方板  
编号: YC3005  
Description: full-punching aluminium square plate  
Code: YC3005

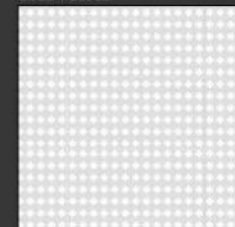

品名: Ø1.8中方格冲孔铝方板  
编号: YC3006  
Description: medium-check punching aluminium square plate  
Code: YC3006

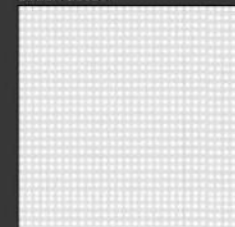

品名: Ø1.8小方格冲孔铝方板  
编号: YC3007  
Description: small-check punching aluminium square plate  
Code: YC3007

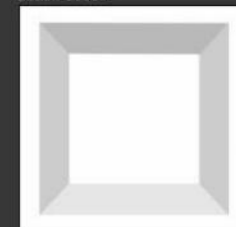

品名: #型铝方板  
编号: YC3008  
Description: #-shape aluminium square plate  
Code: YC3008

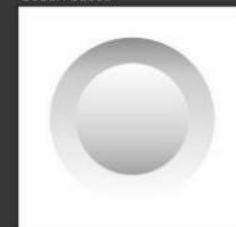

品名: 圆形铝方板  
编号: YC3009  
Description: round aluminium square plate  
Code: YC3009

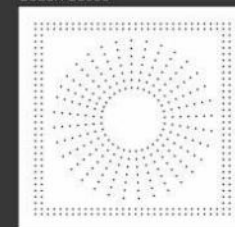

品名: Ø3太阳花冲孔铝方板  
编号: YC3010  
Description: daisy punching aluminium square plate  
Code: YC3010

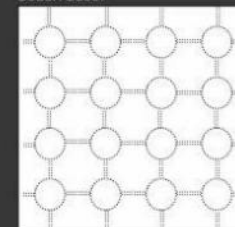

品名: Ø3小圆形冲孔铝方板  
编号: YC3011  
Description: small round aluminium square plate  
Code: YC3011

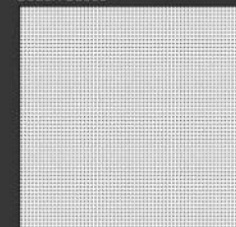

品名: Ø2.2全冲孔铝方板  
编号: YC3012  
Description: full-punching aluminium square plate  
Code: YC3012



# PROJECT CASE SHOW

工程案例展示

PROJECT CASE  
SHOW  
工程案例展示

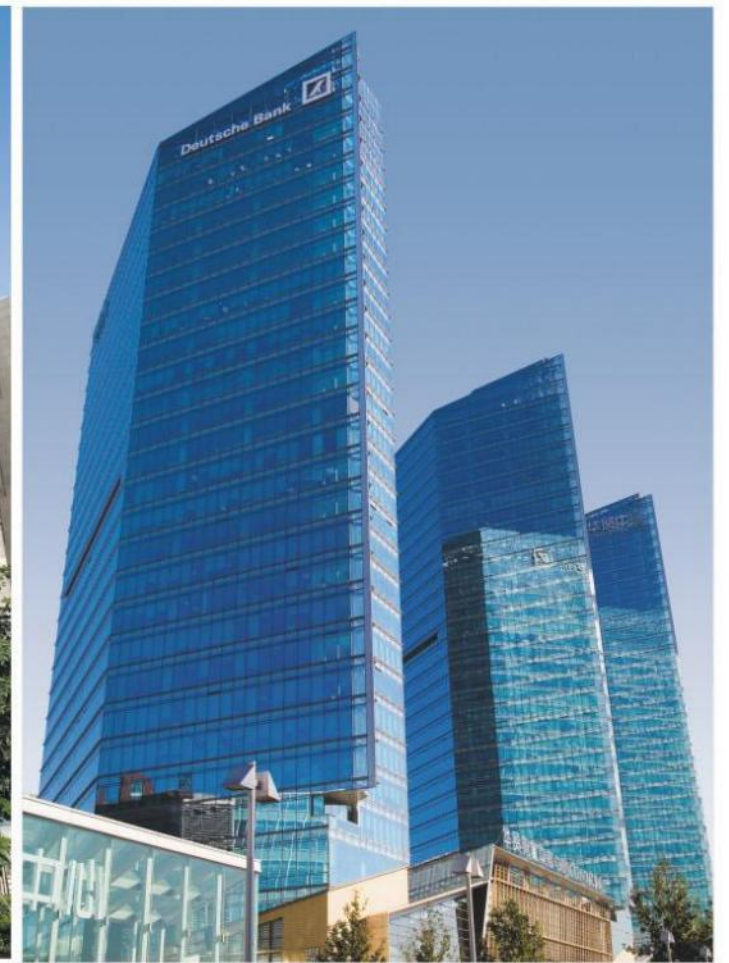

PROJECT CASE  
SHOW  
工程案例展示





## SECTION PROJECT DIRECTORY 部分工程名录

北京西单赛特购物中心  
北京海淀剧院  
北京西城区检察院  
王府井外文书店  
国家信息中心  
上海金山大学城  
上海体育馆  
南京金鹰国际购物中心  
沈阳辽沈战役纪念馆  
济南三箭公司实验中学  
济南市中心医院  
胜利油田总局  
山东省工商行政管理局  
山东将军集团烟厂  
禹城市东方大厦  
徐州市鼓楼区法院  
徐州市古建陈列馆  
中国矿业大学  
郑州市地税大厦  
郑州市图书馆  
昆明市嘉华大酒店  
珠海市长江实业花园  
南昌烟草大厦  
浙江平湖人民医院  
宁波汽车站  
厦门太古机场  
厦门会计学院  
泉州国贸大厦  
常州天安数码城  
常州供电局  
河北邢台龙泉山庄度假村  
安徽大学  
合肥炮兵学院  
合肥客运总站  
合肥市黄金广场电脑城  
湖南大学  
长沙电力局  
国际科技大学  
好百年家具广场  
长沙附二附三医院  
呼和浩特地税局办公大楼  
长沙市农行网点  
上海南江大学

上海师范大学  
南京东南大学  
国际科技大学  
无锡火车站  
贵阳百货大楼  
杭州涌金广场  
广西南宁地区各邮电局  
青岛海洋大学  
北京丰台饭店  
北京玉泉大厦  
北京八一中学  
武警总部  
上海浦东国际机场  
上海长途汽车站  
南京喜来登大酒店  
南京师范大学  
河南电视台大楼  
济南遥墙机场  
济南市欧亚家具城  
山东师范大学  
山东徽山邮电局  
山东建工集团  
禹城市第一中学  
徐州发电厂  
徐州一中体育馆  
泉山区法院  
郑州银基商贸城  
昆明机场  
珠海市海怡湾畔  
江西省八二八宾馆  
贵阳百货大楼  
杭州临安外贸公司  
宁波鄞州汽车站  
福建炼油乙烯分析实验楼  
厦门集美理工学院  
晋江燃气发电厂  
常州天宁法院  
常州广化桥建行总行  
合肥国资委  
合肥商业学院  
淮南矿二院  
合肥交警中心  
合淮阜高速公司服务站  
长沙邮政局  
长沙市建行网点  
三一重工  
湘乡中学  
南京三江学院  
呼和浩特新华书店  
杭州影剧院  
上海国际赛车场(部分)  
上海浦东张江高科技园区  
南京中央商场  
安徽省经贸委经营楼

无锡地区人民医院  
杭州邮电大学  
浙江余姚服装市场  
广西电信局  
常州第一人民医院  
北京富顿商务中心  
北京中山公园  
中关村电子科贸枢纽中心  
呼和浩特市政府驻京办事处  
上海虹桥国际机场  
上海火车站  
南京希尔顿大酒店  
南京建邺区人民政府大楼  
沙泽市南华广场  
济南市法官培训学院  
济宁人民医院  
山东铁路局  
山东省房地产开发总公司  
山东恒信发展公司龙口重点工程  
徐州市三中教学楼  
徐州师范大学工学院  
徐州中国人民解放军73061部队装备部  
江苏省睢宁财政局  
安徽省淮北行政办公大楼  
昆明市天恒大酒店  
四川中国移动分公司  
江西省第一附属医院  
贵阳东风大厦  
宁波市国家安全局  
厦门大学  
厦门金海湾花园  
常州人才市场  
常州湖塘中行  
河北金牛集团: 东庞矿、葛泉矿  
安徽大剧院  
中国科技大学  
金寨火车站  
阜阳火车站  
长沙理工大学  
湖南广电中心  
长沙市农行网点  
中联重科  
湖南省路桥收费网点  
呼和浩特电力大厦  
上海地铁站(部分)  
上海交通大学  
南京农业大学  
南京金盛国际家居广场  
合肥市阜阳市百货大楼  
无锡欧翔超市  
杭州财税大楼  
山东莱阳农学院  
广西邕宁地税局  
常州农行总行

