

Drive^{IT} Low Voltage AC Drives

User's Manual

ACS510-01 Drives (1.1...160 kW)



ABB

ACS510 Drive Manuals

GENERAL MANUALS

ACS510-01 User's Manual (1.1...160 kW)

- Safety
- Installation
- Start-Up
- Embedded Fieldbus
- Fieldbus Adapter
- Diagnostics
- Maintenance
- Technical Data

OPTION MANUALS

(Fieldbus Adapters, I/O Extension Modules etc., manuals delivered with optional equipment)

Relay Output Extension Module (typical title)

- Installation
- Start-Up
- Diagnostics
- Technical Data

The Industrial^{IT} wordmark and Product names in the form Drive^{IT} are registered or pending trademarks of ABB.

CANopen is a registered trademark of CAN in Automation e.V.

ControlNet is a registered trademark of ControlNet International.

DeviceNet is a registered trademark of Open DeviceNet Vendor Association.

DRIVECOM is a registered trademark of DRIVECOM User Organization.

Interbus is a registered trademark of Interbus Club.

LonWorks is a registered trademark of Echelon Corp.

Metasys is a registered trademark of Johnson Controls Inc.

Modbus and Modbus Plus are registered trademarks of Schneider Automation Inc.

PROFIBUS is a registered trademark of Profibus Trade Org.

PROFIBUS-DP is a registered trademark of Siemens AG.

Safety



Warning! The ACS510 adjustable speed AC drive should ONLY be installed by a qualified electrician.



Warning! Even when the motor is stopped, dangerous voltage is present at the Power Circuit terminals U1, V1, W1 and U2, V2, W2 and, depending on the frame size, UDC+ and UDC-, or BRK+ and BRK-.



Warning! Dangerous voltage is present when input power is connected. After disconnecting the supply, wait at least 5 minutes (to let the intermediate circuit capacitors discharge) before removing the cover.



Warning! Even when power is removed from the input terminals of the ACS510, there may be dangerous voltage (from external sources) on the terminals of the relay outputs R01...R03.



Warning! When the control terminals of two or more drive units are connected in parallel, the auxiliary voltage for these control connections must be taken from a single source which can either be one of the units or an external supply.



Warning! The ACS510-01 is not a field repairable unit. Never attempt to repair a malfunctioning unit; contact the factory or your local Authorized Service Center for replacement.



Warning! The ACS510 will start up automatically after an input voltage interruption if the external run command is on.



Warning! The heat sink may reach a high temperature. See "Technical Data" on page 211.



Warning! If the drive will be used in a floating network, remove screws at EM1 and EM3 (Frame size R1...R4), or F1 and F2 (Frame size R5 or R6). See diagrams on page 15 and page 16 respectively. Also see "Unsymmetrically Grounded Networks" and "Floating Networks" on page 217.



Warning! Do not attempt to install or remove EM1, EM3, F1 or F2 screws while power is applied to the drive's input terminals.

Note! For more technical information, contact the factory or your local ABB sales representative.

Use of Warnings and Notes

There are two types of safety instructions throughout this manual:

- Notes draw attention to a particular condition or fact, or give information on a subject.
- Warnings caution you about conditions which can result in serious injury or death and/or damage to the equipment. They also tell you how to avoid the danger. The warning symbols are used as follows:



Dangerous voltage warning warns of high voltage which can cause physical injury and/or damage to the equipment.



General warning warns about conditions, other than those caused by electricity, which can result in physical injury and/or damage to the equipment

Table of Contents

Safety

Use of Warnings and Notes	4
---------------------------------	---

Table of Contents

Installation

Installation Flow Chart	7
Preparing for Installation	8
Installing the Drive	11

Start-Up

Control Panels	28
Assistant Control Panel	28
Basic Control Panel	37
Application Macros	42
Complete Parameter List for ACS510	52
Complete Parameter Descriptions	64

Embedded Fieldbus

Overview	143
Planning	144
Mechanical and Electrical Installation – EFB	144
Communication Set-up – EFB	145
Activate Drive Control Functions – EFB	147
Feedback from the Drive – EFB	151
Diagnostics – EFB	152
Modbus Protocol Technical Data	155
ABB Control Profiles Technical Data	163

Fieldbus Adapter

Overview	175
Planning	177
Mechanical and Electrical Installation – FBA	178
Communication Set-up – FBA	179
Activate Drive Control Functions – FBA	179
Feedback from the Drive – FBA	182
Diagnostics – FBA	183
ABB Drives Profile Technical Data	186
Generic Profile Technical Data	194

Diagnostics

Diagnostic Displays	196
Correcting Faults	197
Correcting Alarms	202

Maintenance

Maintenance Intervals	207
Heatsink	207
Main Fan Replacement	208
Internal Enclosure Fan Replacement	209
Capacitors	209
Control Panel	210

Technical Data

Ratings	211
Input Power Connections	214
Motor Connections	220
Brake Components	225
Control Connections	229
Efficiency	230
Cooling	230
Dimensions and Weights	232
Degrees of Protection	234
Ambient Conditions	235
Materials	236
Applicable Standards	236
Liability Limits	237

Index

Installation

Study these installation instructions carefully before proceeding. **Failure to observe the warnings and instructions may cause a malfunction or personal hazard.**



Warning! Before you begin read "Safety" on page 3.

Installation Flow Chart

The installation of the ACS510 adjustable speed AC drive follows the outline below. The steps must be carried out in the order shown. At the right of each step are references to the detailed information needed for the correct installation of the drive.

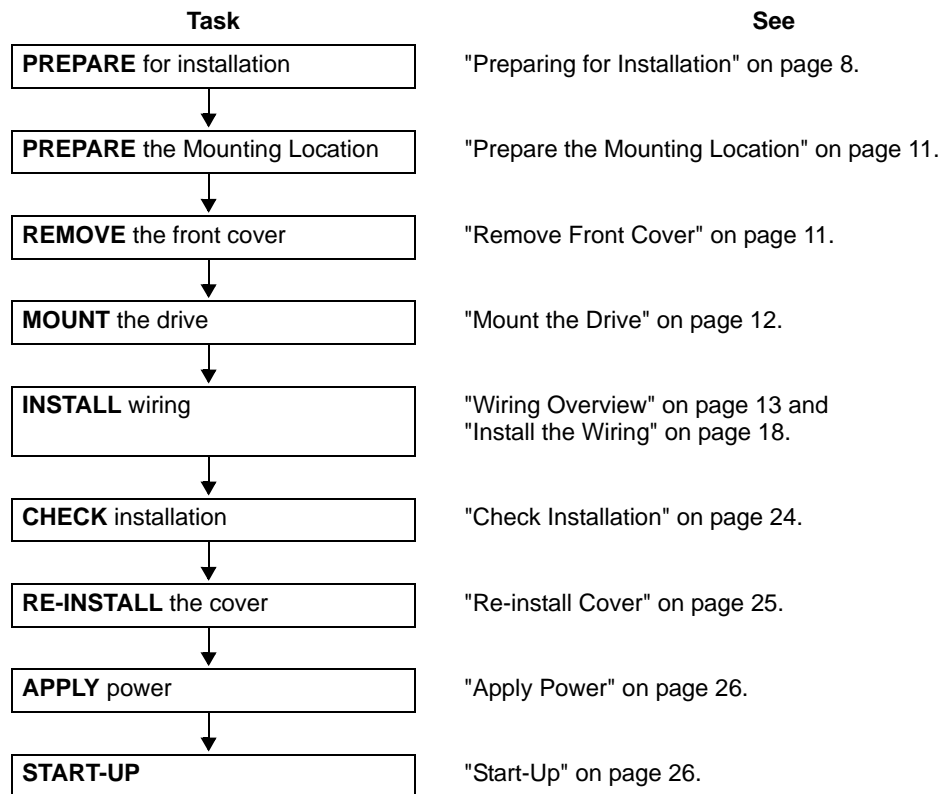

Preparing for Installation

Lifting the Drive

Lift the drive only by the metal chassis.

Unpacking the Drive

1. Unpack the drive.
2. Check for any damage and notify the shipper immediately if damaged components are found.
3. Check the contents against the order and the shipping label to verify that all parts have been received.



IP2040

Drive Identification



Drive Labels

To determine the type of drive you are installing, refer to either:

- Serial number label attached on upper part of the chokeplate between the mounting holes, or

ACS510-01-09A4-4+N688		
U₁	3~ 380...480 V	 Ser. no.*3050700001*
I_{2N}	9.4 A	
P_N	4 kW	

- Type code label attached on the heat sink – on the right side of the drive cover.

Input	U₁	3~ 380...480 V	
	I_{1N}	9.4 A	
	f₁	48...63 Hz	
Output	U₂	3~ 0...U ₁ V	 Ser. no.*3050700001*
	I_{2N}	9.4 A	
	f₂	0...50 Hz	
Motor	P_N	4 kW	
ACS510-01-09A4-4+N688			

Type Code

Use the following chart to interpret the type code found on either label.

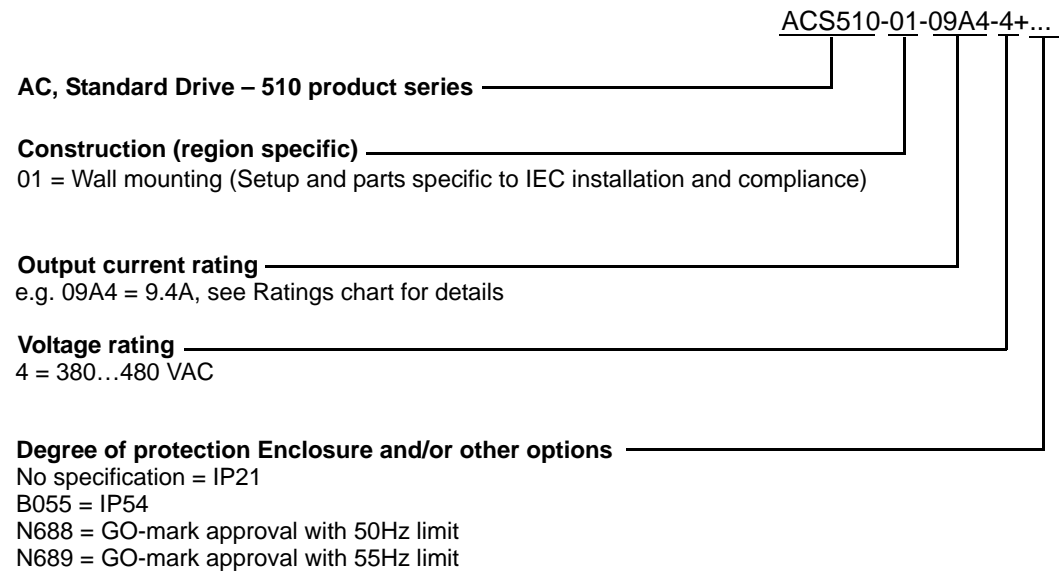

Ratings and Frame Size

The chart in "Ratings" on page 211 lists technical specifications, and identifies the drive's frame size – significant, since some instructions in this document, vary, depending on the drive's frame size. To read the Ratings table, you need the "Output current rating" entry from the type code. Also, when using the Ratings table, note that the table is broken into sections based on the drive's "Voltage rating".

Motor Compatibility

The motor, drive, and supply power must be compatible:

Motor Specification	Verify	Reference
Motor type	3-phase induction motor	–
Nominal current	Motor value is within this range: $0.2...2.0 * I_{2n}$	<ul style="list-style-type: none"> Type code label on drive, entry for Output I_{2n}, or Type code on drive and rating table in "Technical Data" on page 211.
Nominal frequency	10...500 Hz N688:10...50Hz N689:10...55Hz	–
Voltage range	Motor is compatible with the ACS510 voltage range.	380...480 V

Tools Required

To install the ACS510 you need the following:

- Screwdrivers (as appropriate for the mounting hardware used)
- Wire stripper

- Tape measure
- Drill
- Mounting hardware: screws or nuts and bolts, four each. The type of hardware depends on the mounting surface and the frame size:

Frame Size	Mounting Hardware	
R1...R4	M5	#10
R5	M6	1/4 in
R6	M8	5/16 in

Suitable Environment and Enclosure

Confirm that the site meets the environmental requirements. To prevent damage prior to installation, store and transport the drive according to the environmental requirements specified for storage and transportation. See "Ambient Conditions" on page 235.

Confirm that the enclosure is appropriate, based on the site contamination level:

- IP21 enclosure. The site must be free of airborne dust, corrosive gases or liquids, and conductive contaminants such as condensation, carbon dust, and metallic particles.
- IP54 enclosure. This enclosure provides protection from airborne dust and light sprays or splashing water from all directions.

Suitable Mounting Location

Confirm that the mounting location meets the following constraints:

- The drive must be mounted vertically on a smooth, solid surface, and in a suitable environment as defined above.
- The minimum space requirements for the drive are the outside dimensions (see "Outside Dimensions" on page 233), plus air flow space around the unit (see "Cooling" on page 230).
- The distance between the motor and the drive is limited by the maximum motor cable length. See either "Motor Connection Specifications" on page 220, or "Motor Cable Requirements for CE Compliance" on page 223.
- The mounting site must support the drive's modest weight. See "Weight" on page 234.

Installing the Drive



Warning! Before installing the ACS510, ensure the input power supply to the drive is off.

Prepare the Mounting Location

The ACS510 should only be mounted where all of the requirements defined in "Preparing for Installation" on page 8 are met.

1. Mark the position of the mounting holes.
2. Drill the holes.

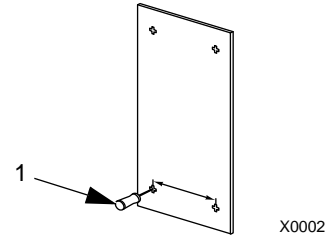

Note! Frame sizes R3 and R4 have four holes along the top. Use only two. If possible, use the two outside holes (to allow room to remove the fan for maintenance).

Note! ACS400 drives can be replaced using the original mounting holes. For R1 and R2 frame sizes, the mounting holes are identical. For R3 and R4 frame sizes, the inside mounting holes on the top of ACS510 drives match ACS400 mounts.

Remove Front Cover

IP21

1. Remove the control panel, if attached.
2. Loosen the captive screw at the top.
3. Pull near the top to remove the cover.

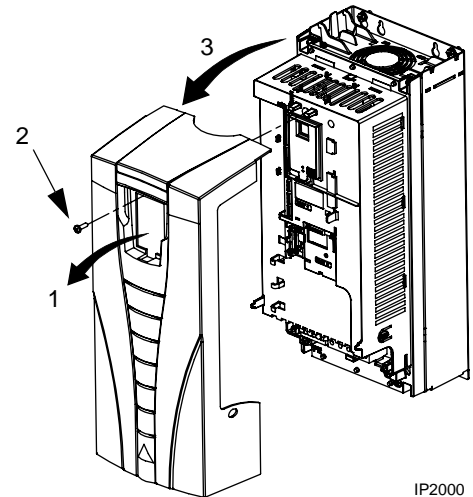

IP54

1. If hood is present: Remove screws (2) holding hood in place.
2. If hood is present: Slide hood up and off of the cover.
3. Loosen the captive screws around the edge of the cover.
4. Remove the cover.

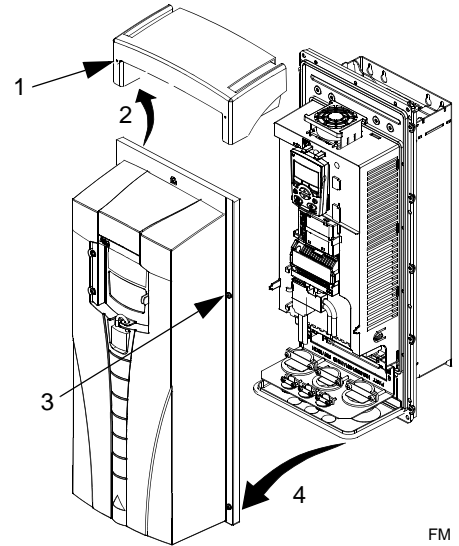
**Mount the Drive****IP21**

1. Position the ACS510 onto the mounting screws or bolts and securely tighten in all four corners.

Note! Lift the ACS510 by its metal chassis (frame size R6 by the lifting holes on both sides at the top).

2. Non-English speaking locations: Add a warning sticker in the appropriate language over the existing warning on the top of the module.

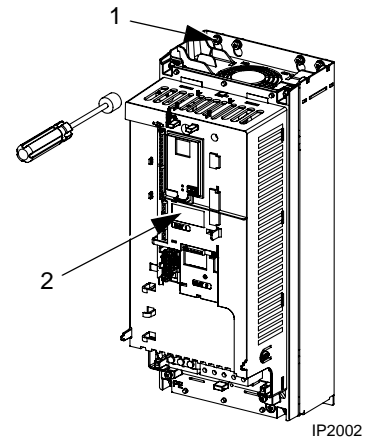
**IP54**

For the IP54 enclosures, rubber plugs are required in the holes provided for access to the drive mounting slots.

1. As required for access, remove the rubber plugs. Push plugs out from the back of the drive.
2. R5 & R6: Align the sheet metal hood (not shown) in front of the drive's top mounting holes. (Attach as part of next step.)
3. Position the ACS510 onto the mounting screws or bolts and securely tighten in all four corners.

Note! Lift the ACS510 by its metal chassis (frame size R6 by the lifting holes on both sides at the top).

4. Re-install the rubber plugs.

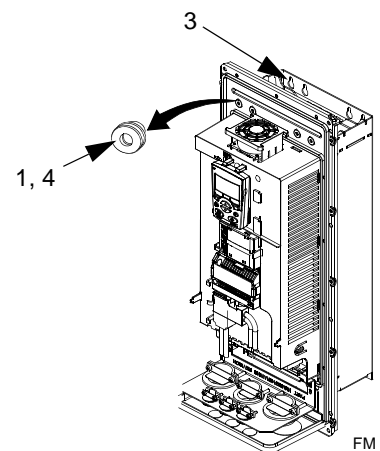

5. Non-English speaking locations: Add a warning sticker in the appropriate language over the existing warning on the top of the module.

Wiring Overview

Conduit/Gland Kit

Wiring drives with the IP21 Enclosure requires a conduit/gland kit with the following items:

- Conduit/gland box
- Five (5) cable clamps
- Screws
- Cover

The kit is included with IP21 Enclosures.

Wiring Requirements



Warning! Ensure the motor is compatible for use with the ACS510. The ACS510 must be installed by a competent person in accordance with the considerations defined in "Preparing for Installation" on page 8. If in doubt, contact your local ABB sales or service office.

As you install the wiring, observe the following:

- There are four sets of wiring instructions – one set for each combination of drive enclosure type (IP21 and IP54), and wiring type (conduit or cable). Be sure to select the appropriate procedure.
- Determine electro-magnetic compliance (EMC) requirements per local codes. See "Motor Cable Requirements for CE Compliance" on page 223. In general:
 - Follow local codes for cable size.
 - Keep these four classes of wiring separated: input power wiring, motor wiring, control/communications wiring, and braking unit wiring.
- When installing input power and motor wiring, refer to the following, as appropriate:

Terminal	Description	Specifications and Notes
U1, V1, W1	3-phase power supply input	"Input Power Connections" on page 214.
PE	Protective Ground	"Ground Connections" on page 216.
U2, V2, W2	Power output to motor	"Motor Connections" on page 220.

- To locate input power and motor connection terminals, see "Power Connection Diagrams" starting on page 15. For specifications on power terminals, see "Drive's Power Connection Terminals" on page 218.
- For frame sizes R1...R4 in unsymmetrically grounded networks, see "Unsymmetrically Grounded Networks" on page 217.
- For floating (or impedance grounded) networks, see "Floating Networks" on page 217.

- For frame size R6, see "Power Terminal Considerations – R6 Frame Size" on page 218 to install the appropriate cable lugs.
- For drives using braking (optional), refer to the following, as appropriate:

Frame Size	Terminal	Description	Braking Accessory
R1, R2	BRK+, BRK-	Braking resistor	Braking resistor. See "Brake Components" on page 225.
R3, R4, R5, R6	UDC+, UDC-	DC bus	Contact your ABB representative to order either: <ul style="list-style-type: none"> • Braking unit or • Chopper and resistor

- When installing control wiring, refer to the following sections, as appropriate:
 - "Control Terminals Table" on page 17.
 - "Control Connections" on page 229.
 - "Application Macros" on page 42.
 - "Complete Parameter Descriptions" on page 63.
 - "Embedded Fieldbus" on page 143.
 - "Fieldbus Adapter" on page 175.

Power Connection Diagrams

The following diagram shows the terminal layout for frame size R3, which, in general, applies to frame sizes R1...R6, except for the R5/R6 power and ground terminals.

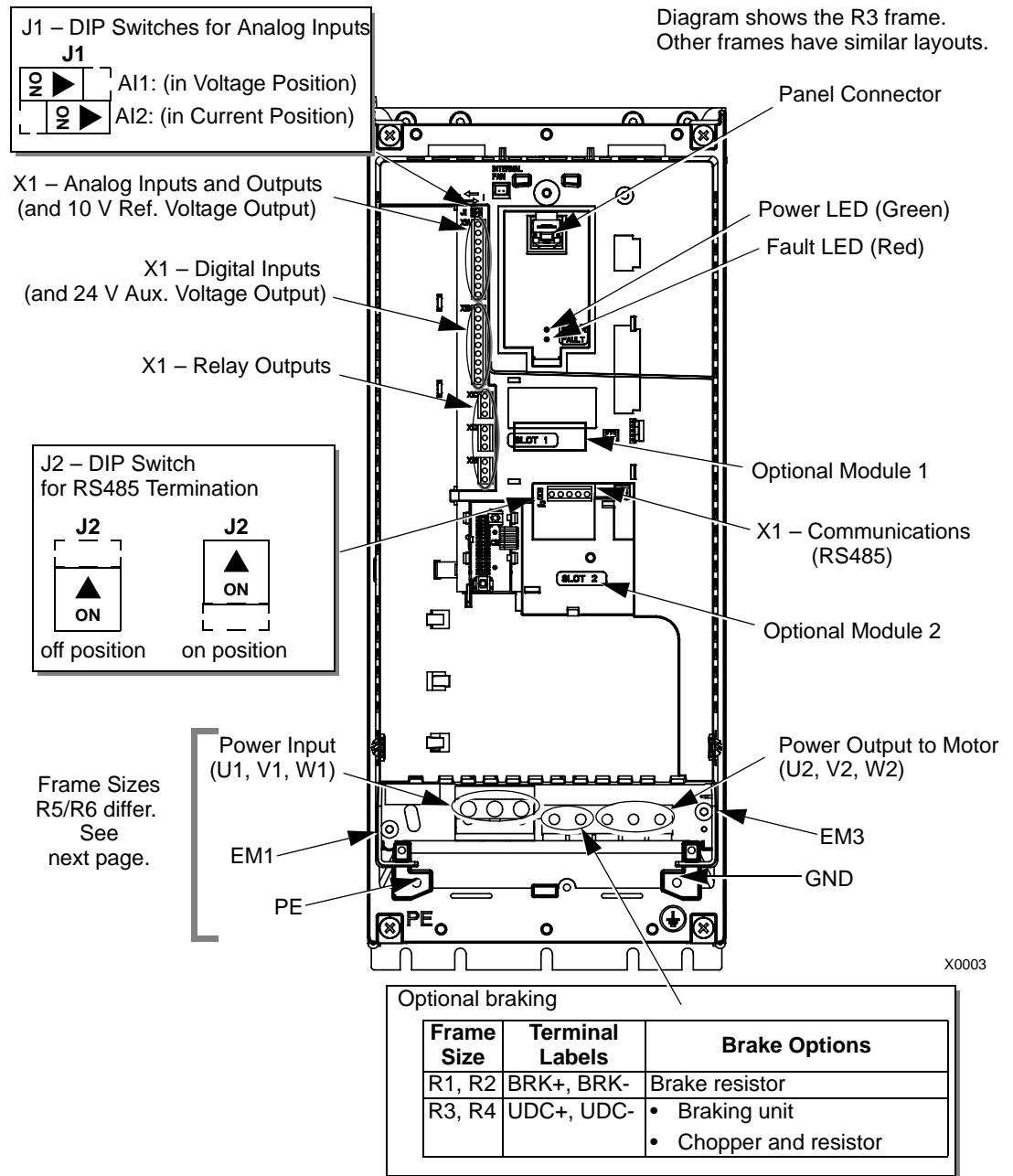

Warning! For floating, impedance grounded, or unsymmetrically grounded networks, disconnect the internal RFI filter by removing:
 - screws EM1 and EM3.
 See "Floating Networks" on page 217.



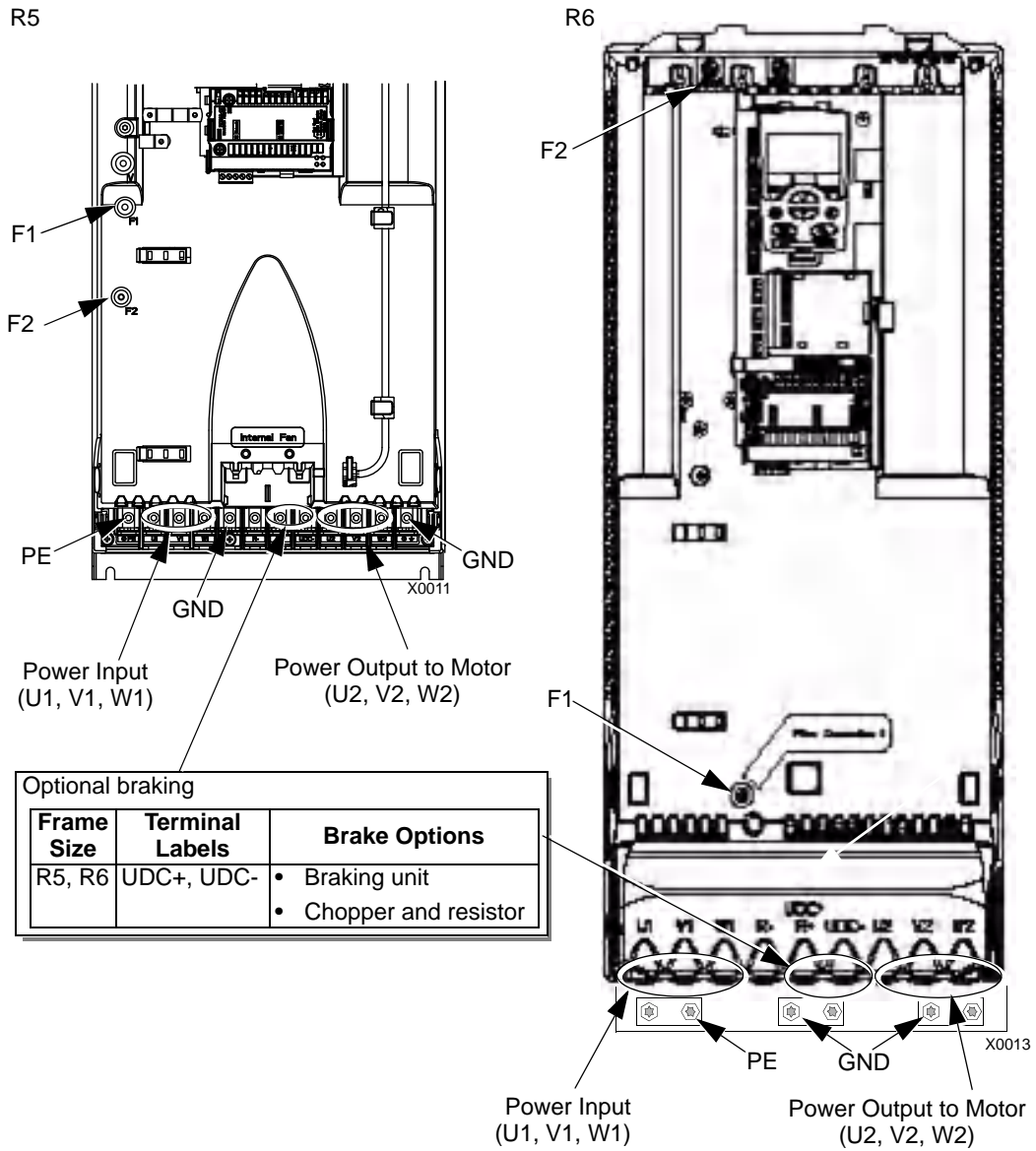

The following diagram shows the power and ground terminal layout for frame sizes R5 and R6



Warning! For floating, impedance grounded, or unsymmetrically grounded networks, disconnect the internal RFI filter by removing screws: F1 and F2. See "Floating Networks" on page 217.

Control Terminals Table

The following provides information for connecting control wiring at X1 on the drive.

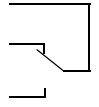
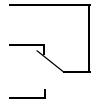
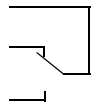
	X1	Hardware Description		
Analog I/O	1	SCR	Terminal for signal cable screen. (Connected internally to chassis ground.)	
	2	AI1	Analog input channel 1, programmable. Default ² = frequency reference. Resolution 0.1%, accuracy $\pm 1\%$.	
			J1:AI1 OFF: 0...10 V ($R_i = 312 \text{ k}\Omega$) 	
			J1:AI1 ON: 0...20 mA ($R_i = 100 \Omega$) 	
	3	AGND	Analog input circuit common (connected internally to chassis gnd. through 1 M Ω).	
	4	+10 V	Potentiometer reference source: 10 V $\pm 2\%$, max. 10 mA ($1\text{k}\Omega \leq R \leq 10\text{k}\Omega$).	
	5	AI2	Analog input channel 2, programmable. Default ² = not used. Resolution 0.1%, accuracy $\pm 1\%$.	
			J1:AI2 OFF: 0...10 V ($R_i = 312 \text{ k}\Omega$) 	
			J1:AI2 ON: 0...20 mA ($R_i = 100 \Omega$) 	
6	AGND	Analog input circuit common (connected internally to chassis gnd. through 1 M Ω).		
7	AO1	Analog output, programmable. Default ² = frequency. 0...20 mA (load < 500 Ω). Accuracy $\pm 3\%$.		
8	AO2	Analog output, programmable. Default ² = current. 0...20 mA (load < 500 Ω). Accuracy $\pm 3\%$.		
9	AGND	Analog output circuit common (connected internally to chassis gnd. through 1 M Ω).		
Digital Inputs ¹	10	+24 V	Auxiliary voltage output 24 V DC / 250 mA (reference to GND), short circuit protected.	
	11	GND	Auxiliary voltage output common (connected internally as floating).	
	12	DCOM	Digital input common. To activate a digital input, there must be $\geq +10 \text{ V}$ (or $\leq -10 \text{ V}$) between that input and DCOM. The 24 V may be provided by the ACS510 (X1-10) or by an external 12...24 V source of either polarity.	
	13	DI1	Digital input 1, programmable. Default ² = start/stop.	
	14	DI2	Digital input 2, programmable. Default ² = fwd/rev.	
	15	DI3	Digital input 3, programmable. Default ² = constant speed sel (code).	
	16	DI4	Digital input 4, programmable. Default ² = constant speed sel (code).	
	17	DI5	Digital input 5, programmable. Default ² = ramp pair selection (code).	
18	DI6	Digital input 6, programmable. Default ² = not used.		
Relay Outputs	19	RO1C		Relay output 1, programmable. Default ² = Ready Maximum: 250 V AC / 30 V DC, 2 A Minimum: 500 mW (12 V, 10 mA)
	20	RO1A		
	21	RO1B		
	22	RO2C		Relay output 2, programmable. Default ² = Running Maximum: 250 V AC / 30 V DC, 2 A Minimum: 500 mW (12 V, 10 mA)
	23	RO2A		
	24	RO2B		
	25	RO3C		Relay output 3, programmable. Default ² = Fault (-1) Maximum: 250 V AC / 30 V DC, 2 A Minimum: 500 mW (12 V, 10 mA)
	26	RO3A		
	27	RO3B		

¹ Digital input impedance 1.5 k Ω . Maximum voltage for digital inputs is 30 V.

² Default values depend on the macro used and software options. Values specified are for the default

macro. See "Application Macros" on page 42.

Note! Terminals 3, 6, and 9 are at the same potential.

Note! For safety reasons the fault relay signals a "fault" when the ACS510 is powered down.

You can wire the digital input terminals in either a PNP or NPN configuration.

PNP connection (source)

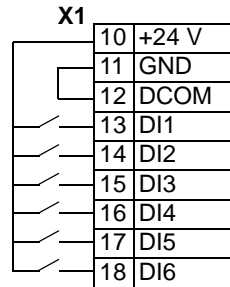

NPN connection (sink)

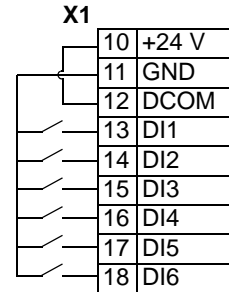

Install the Wiring

Checking Motor and Motor Cable Insulation



Warning! Check the motor and motor cable insulation before connecting the drive to input power. For this test, make sure that motor cables are NOT connected to the drive.

1. Complete motor cable connections to the motor, but NOT to the drive output terminals (U2, V2, W2).
2. At the drive end of the motor cable, measure the insulation resistance between each motor cable phase and Protective Earth (PE): Apply a voltage of 1 kV DC and verify that resistance is greater than 1 Mohm.

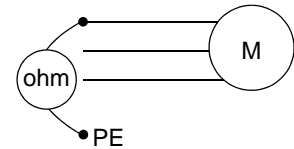

Wiring IP21 Enclosure with Cables

1. Open the appropriate knockouts in the conduit/gland box. (See "Conduit/Gland Kit" above.)
2. Install the cable clamps for the power/motor cables.
3. On the input power cable, strip the sheathing back far enough to route individual wires.
4. On the motor cable, strip the sheathing back far enough to expose the copper wire screen so that the screen can be twisted into a pig-tail. Keep the pig-tail short to minimize noise radiation.

360 ° grounding under the clamp is recommended for the motor cable to minimize noise radiation. In this case, remove the sheathing at the cable clamp.

5. Route both cables through the clamps.
6. Strip and connect the power/motor wires, and the power ground wire to the drive terminals.

Note! For R5 frame size, the minimum power cable size is 25 mm² (4 AWG).

For R6 frame size, refer to "Power Terminal Considerations – R6 Frame Size" on page 218.

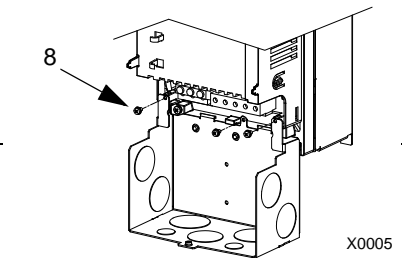
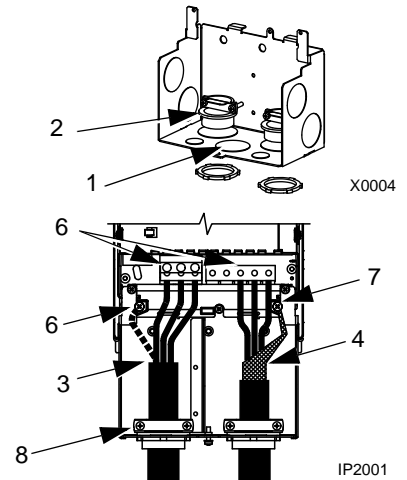

7. Connect the pig-tail created from the motor cable screen to the GND terminal.
8. Install conduit/gland box and tighten the cable clamps.
9. Install the cable clamp(s) for the control cable(s). (Power/motor cables and clamps not shown in figure.)
10. Strip control cable sheathing and twist the copper screen into a pig-tail.
11. Route control cable(s) through clamp(s) and tighten clamp(s).
12. Connect the ground screen pig-tail for digital and analog I/O cables at X1-1. (Ground only at drive end.)
13. Connect the ground screen pig-tail for RS485 cables at X1-28 or X1-32. (Ground only at drive end.)
14. Strip and connect the individual control wires to the drive terminals. See "Control Terminals Table" on page 17.
15. Install the conduit/gland box cover (1 screw).

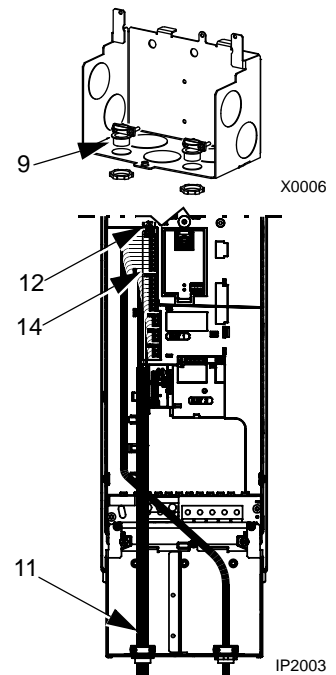

Wiring IP21 Enclosure with Conduit

1. Open the appropriate knockouts in the conduit/gland box. (See "Conduit/Gland Kit" above.)
2. Install thin-wall conduit clamps (not supplied).

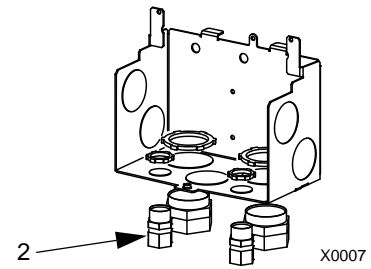

3. Install conduit/gland box.
4. Connect conduit runs to box.

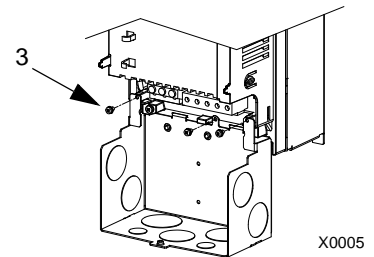

5. Route input power and motor wiring through conduits (must be separate conduit runs).
6. Strip wires.
7. Connect power, motor, and ground wires to the drive terminals.

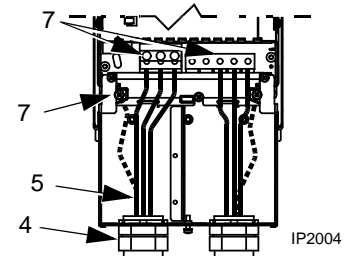

Note! For R5 frame size, the minimum power cable size is 25 mm² (4 AWG).

For R6 frame size, refer to "Power Terminal Considerations – R6 Frame Size" on page 218.

8. Route the control cable through the conduit (must be separate from input power and motor conduit runs).
9. Strip the control cable sheathing and twist the copper screen into a pig-tail.
10. Connect the ground screen pig-tail for digital and analog I/O cables at X1-1. (Ground only at drive end.)
11. Connect the ground screen pig-tail for RS485 cables at X1-28 or X1-32. (Ground only at drive end.)
12. Strip and connect the individual control wires to the drive terminals. See "Control Terminals Table" on page 17.
13. Install the conduit/gland box cover (1 screw).

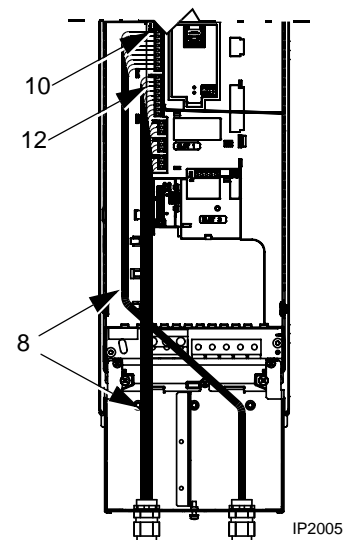

Wiring **IP54** Enclosure with **Cables**

1. Cut the cable seals as needed for the power, motor, and control cables. (The cable seals are cone-shaped, rubber seals on the bottom of the drive.)

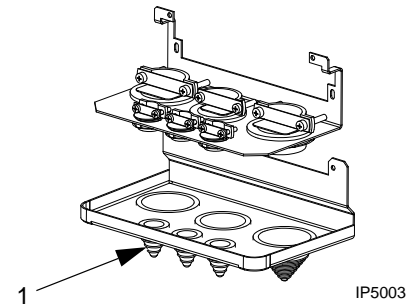

2. On the input power cable, strip the sheathing back far enough to route individual wires.
3. On the motor cable, strip the sheathing back far enough to expose the copper wire screen so that the screen can be twisted into a pig-tail. Keep the pig-tail short to minimize noise radiation.

360° grounding under the clamp is recommended for the motor cable to minimize noise radiation. In this case, remove the sheathing at the cable clamp.

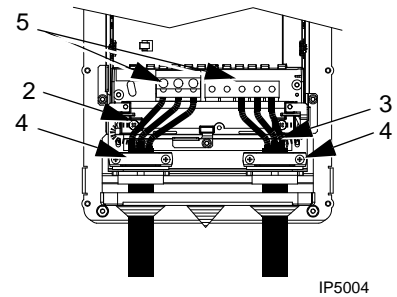

4. Route both cables through the clamps and tighten the clamps.
5. Strip and connect the power/motor wires, and the power ground wire to the drive terminals.

Note! For R5 frame size, the minimum power cable size is 25 mm² (4 AWG). For R6 frame size, refer to "Power Terminal Considerations – R6 Frame Size" on page 218.

6. Connect the pig-tail created from the motor cable screen to the GND terminal.
7. Strip control cable sheathing and twist the copper screen into a pig-tail.
8. Route control cable(s) through clamp(s) and tighten clamp(s).
9. Connect the ground screen pig-tail for digital and analog I/O cables at X1-1. (Ground only at drive end.)
10. Connect the ground screen pig-tail for RS485 cables at X1-28 or X1-32. (Ground only at drive end.)
11. Strip and connect the individual control wires to the drive terminals. See "Control Terminals Table" on page 17.

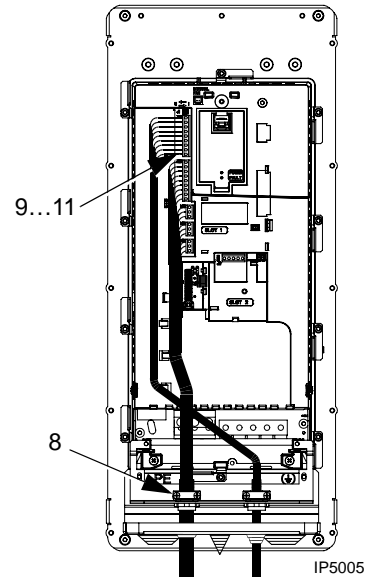

Wiring **IP54** Enclosure with **Conduit**

1. Depends on Frame Size:

- R1...R4: Remove and discard the cable seals where conduit will be installed. (The cable seals are cone-shaped, rubber seals on the bottom of the drive.)
- R5 and R6: Use punch to create holes for conduit connections as needed.

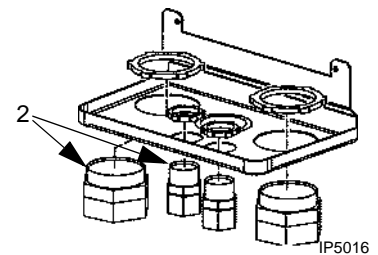
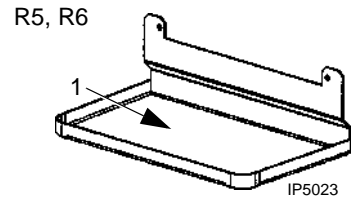
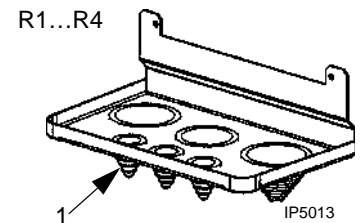

2. For each conduit run, install water tight conduit connectors (not supplied).

3. Route the power wiring through the conduit.
4. Route the motor wiring through the conduit.
5. Strip the wires.
6. Connect the power, motor, and ground wires to the drive terminals.

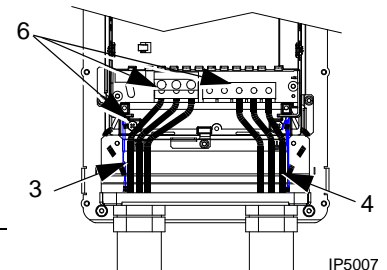

Note! For R5 frame size, the minimum power cable size is 25 mm² (4 AWG).

For R6 frame size, refer to "Power Terminal Considerations – R6 Frame Size" on page 218.

7. Route the control cable through the conduit.
8. Strip the control cable sheathing and twist the copper screen into a pig-tail.
9. Connect the ground screen pig-tail for digital and analog I/O cables at X1-1. (Ground only at drive end.)
10. Connect the ground screen pig-tail for RS485 cables at X1-28 or X1-32. (Ground only at drive end.)
11. Strip and connect the individual control wires to the drive terminals. See "Control Terminals Table" on page 17.

Check Installation

Before applying power, perform the following checks.

✓	Check
	Installation environment conforms to the drive's specifications for ambient conditions.
	The drive is mounted securely.
	Space around the drive meets the drive's specifications for cooling.
	The motor and driven equipment are ready for start.
	For floating networks: The internal RFI filter is disconnected (screws EM1 & EM3 or F1 & F2 removed).
	The drive is properly grounded.
	The input power (mains) voltage matches the drive nominal input voltage.
	The input power (mains) connections at U1, V1, and W1 are connected and tightened as specified.
	The input power (mains) fuses are installed.
	The motor connections at U2, V2, and W2 are connected and tightened as specified.
	The motor cable is routed away from other cables.
	NO power factor compensation capacitors are in the motor cable.
	The control connections are connected and tightened as specified.
	NO tools or foreign objects (such as drill shavings) are inside the drive.
	NO alternate power source for the motor (such as a bypass connection) is connected – no voltage is applied to the output of the drive.

Re-install Cover

IP21

1. Align the cover and slide it on.
2. Tighten the captive screw.
3. Re-install the control panel.

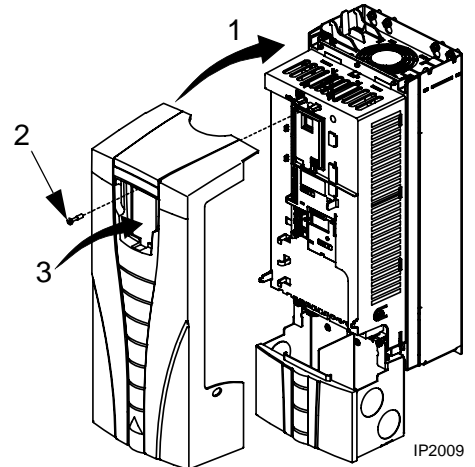

IP54

1. Align the cover and slide it on.
2. Tighten the captive screws around the edge of the cover.
3. R1...R4: Slide the hood down over the top of the cover.
4. R1...R4: Install the two screws that attach the hood.
5. Install the control panel.

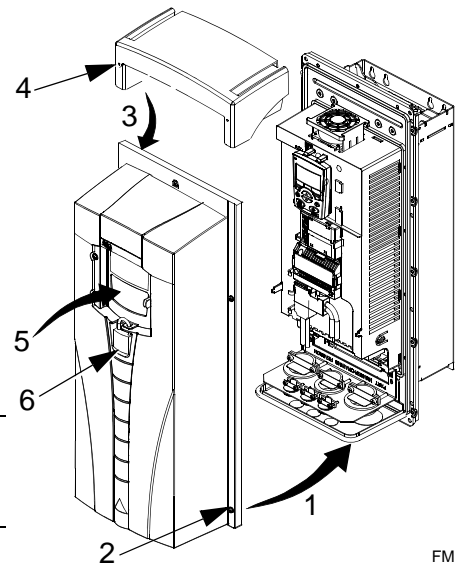

Note! The control panel window must be closed to comply with IP54/UL type 12.

6. Optional: Add a lock (not supplied) to secure the control panel window.

Apply Power

Always re-install the front cover before turning power on.



Warning! The ACS510 will start up automatically at power up, if the external run command is on.

1. Apply input power.

When power is applied to the ACS510, the green LED comes on.

Note! Before increasing motor speed, check that the motor is running in the desired direction.

Start-Up

The ACS510 has default parameter settings that are sufficient for many situations. However, review the following situations. Perform the associated procedures as appropriate.

Motor Data

The motor data on the ratings plate may differ from the defaults in the ACS510. The drive provides more precise control and better thermal protection if you enter the rating plate data.

1. Gather the following from the motor ratings plate:
 - Voltage
 - Nominal motor current
 - Nominal frequency
 - Nominal speed
 - Nominal power
2. Edit parameters 9905...9909 to the correct values.

Macros

Note! Selecting the appropriate macro should be part of the original system design, since the wiring installed in "Control Terminals Table" on page 17 depends on the macro used.

1. Review the macro descriptions in "Application Macros" on page 42. Use the macro that best fits system needs.
2. Edit parameter 9902 to select the appropriate macro.
 - Assistant Control Panel
 - Refer to "Parameters Mode" on page 31, for parameter editing instructions.

- Basic Control Panel: Refer to "Parameters Mode" on page 39, for parameter editing instructions.

Tuning – Parameters

The system can benefit from one or more of the ACS510 special features, and/or fine tuning.

1. Review the parameter descriptions in "Complete Parameter Descriptions" starting on page 63. Enable options and fine tune parameter values as appropriate for the system.
2. Edit parameters as appropriate.

Fault and Alarm Adjustments

The ACS510 can detect a wide variety of potential system problems. For example, initial system operation may generate faults or alarms that indicate set-up problems.

1. Faults and alarms are reported on the control panel with a number. Note the number reported.
2. Review the description provided for the reported fault/alarm:
 - Use the fault and alarm listings on pages 197 and 203 respectively (or page 205 for the Basic Control Panel's alarm listing), or
 - Press the help key (Assistant Control Panel only) while fault or alarm is displayed.
3. Adjust the system or parameters as appropriate.

Start-Up

Start-up configures the drive. This process sets parameters that define how the drive operates and communicates. Depending on the control and communication requirements, the start-up process may require any or all of the following:

- Application macros can be selected to define common, alternate system configurations, using the default settings. See "Application Macros" on page 42.
- Additional refinements can be made using the control panel to manually select and set individual parameters. See "Complete Parameter Descriptions" on page 63.

Control Panels

Use a control panel to control the ACS510, to read status data, and to adjust parameters. The ACS510 works with either of two different control panel types:

- Assistant Control Panel – This panel (described below) includes multi-mode to display and control the ACS510.
- Basic control panel – This panel (described in a later section) provides basic tools for manual entry of parameter values.

Assistant Control Panel

Features

The ACS510 Assistant Control Panel features:

- Alphanumeric control panel with a LCD display
- Language selection for the display
- Drive connection that can be made or detached at any time
- Copy function – Parameters can be copied to the Control Panel memory for later transfer to other drives, or for backup of a particular system.
- Context sensitive help

Controls/Display Overview

The following table summarizes the button functions and displays on the Assistant Control Panel.

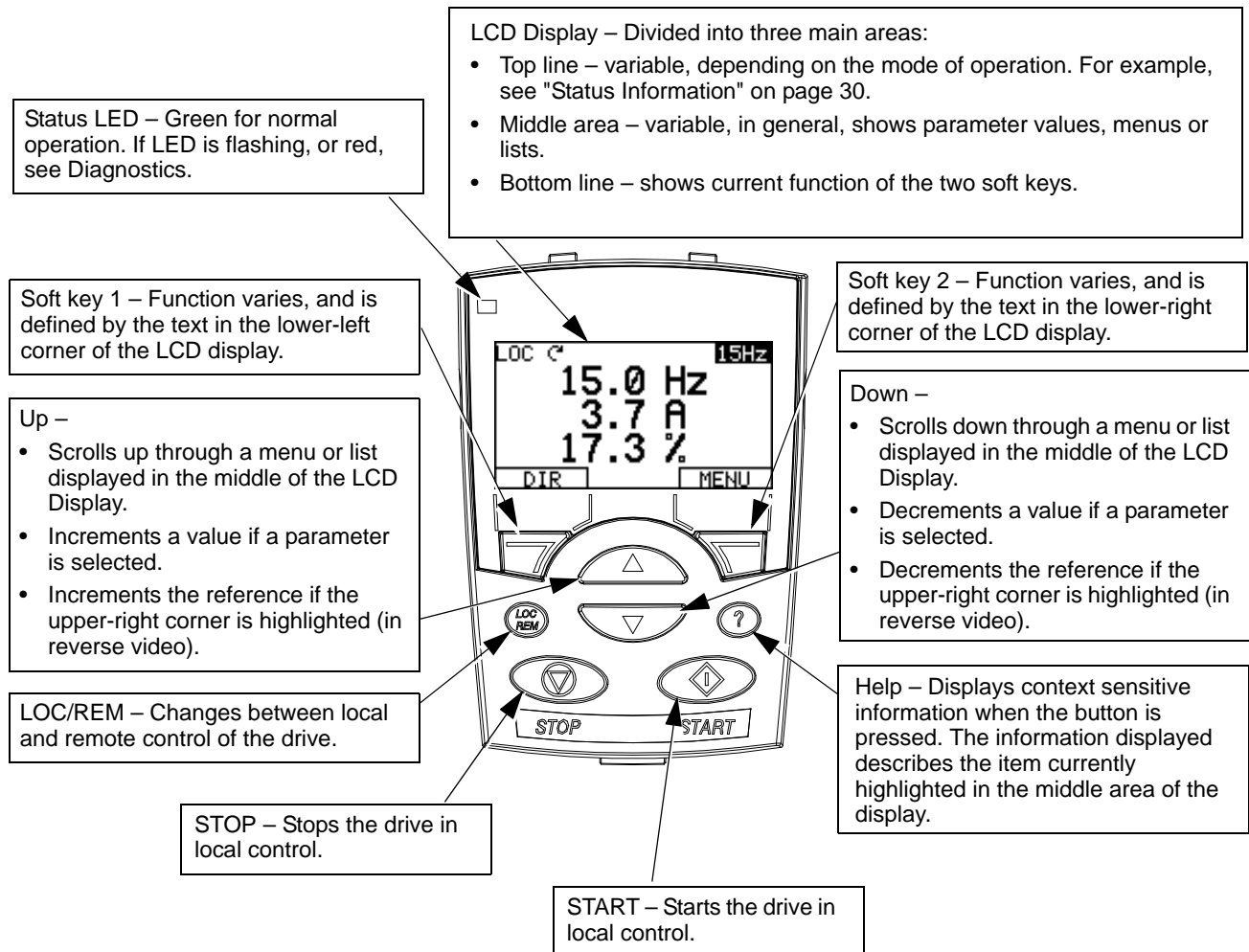

General Display Features

Soft Key Functions

The soft key functions are defined by text displayed just above each key.

Display Contrast

To adjust display contrast, simultaneously press the MENU key and UP or DOWN, as appropriate.

Output Mode

Use the Output mode to read information on the drive's status and to operate the drive. To reach the Output mode, press EXIT until the LCD display shows status information as described below.

Status Information

Top. The top line of the LCD display shows the basic status information of the drive.

- LOC – indicates that the drive control is local, that is, from the control panel.
- REM – indicates that the drive control is remote, such as the basic I/O (X1) or fieldbus.
- ↻ – indicates the drive and motor rotation status as follows:

Control Panel Display	Significance
Rotating arrow (clockwise or counter clockwise)	<ul style="list-style-type: none"> • Drive is running and at setpoint • Shaft direction is forward ↻ or reverse ↺
Rotating dotted blinking arrow	Drive is running but not at setpoint.
Stationary dotted arrow	Start command is present, but motor is not running. E.g. start enable is missing.

- Upper right – shows the active reference.

Middle. Using parameter Group 34, the middle of the LCD display can be configured to display:

- Up to three parameter values.

- By default, the display shows three parameters 0103 (OUTPUT FREQUENCY), 0104 (CURRENT), 0105 (TORQUE).

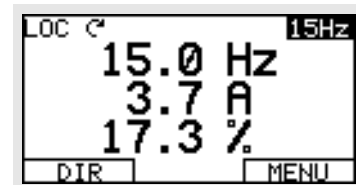

- Use parameters 3401, 3408, and 3415 to select the parameters (from Group 01) to display. Entering “parameter” 0100 results in no parameter displayed. For example, if 3401 = 0100 and 3415 = 0100, then only the parameter specified by 3408 appears in the Control Panel display.
- You can also scale each parameter in the display, for example, to convert the motor speed to a display of conveyor speed. Parameters 3402...3405 scale the parameter specified by 3401, parameters 3409...3412 scale the parameter specified by 3408, etc.

- A bar graph rather than any of the parameter values.

- Enable bar graph displays using parameters 3404, 3411 and 3418.

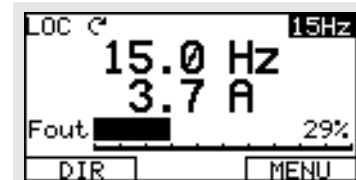

Bottom. The bottom of the LCD display shows:

Lower corners – show the functions currently assigned to the two soft keys.

Operating the Drive

LOC/REM – The very first time the drive is powered up, it is in the remote control (REM) mode, and is controlled from the Control Terminal Block X1.

To switch to local control (LOC) and control the drive using the control panel, press and hold the  button until first, LOCAL CONTROL, or later, LOCAL, KEEP RUN, is displayed:

- Release the button while LOCAL CONTROL is displayed to set the panel reference to the current external reference. The drive stops.
- Release the button when LOCAL, KEEP RUN is displayed, to copy the current run/stop status and the reference from the user I/O.

To switch back to remote control (REM) press and hold the  button until REMOTE CONTROL is displayed.

Start/Stop – To start and stop the drive press the START and STOP buttons.

Shaft direction – To change the shaft direction press DIR (parameter 1003 must be set to 3 (REQUEST)).

Reference – To modify the reference (only possible if the display in the upper right corner is highlighted) press the UP or DOWN buttons (the reference changes immediately).

The reference can be modified when in local control (LOC), and can be parameterized (using Group 11: Reference Select) to also allow modification when in remote control (REM).

Note! The Start/Stop, Shaft direction and Reference functions are only valid in local control (LOC) mode.

Other Modes

Besides the Output mode, the Assistant Control Panel has:

- Other operating modes that are available through the main menu.
- A fault mode that is triggered by faults. The fault mode includes a diagnostic assistant mode.
- An alarm mode that is triggered by drive alarms.

Access to Main Menu and the Other Modes

To reach the main menu:

1. Press EXIT, as necessary, to step back through the menus or lists associated with a particular mode. Continue until you are back to the Output mode.
2. Press MENU from the Output mode.

At this point, the middle of the display is a listing of the other modes, and the top-right text says "Main menu"

3. Press UP/DOWN to scroll to the desired mode.
4. Press ENTER to enter the mode that is highlighted.

The following sections describe each of the other modes.

Parameters Mode

Use the Parameters mode to view and edit parameter values:

1. Select PARAMETERS in the Main Menu.

- Press UP/DOWN to highlight the appropriate parameter group, then press SEL.

```

LOC ↵ PAR GROUPS—01
99 START-UP DATA
01 OPERATING DATA
04 FAULT HISTORY
10 START/STOP/DIR
11 REFERENCE SELECT
EXIT      SEL
  
```

- Press UP/DOWN to highlight the appropriate parameter in a group.

NOTE! The current parameter value appears below the highlighted parameter.

```

LOC ↵ PARAMETERS—
1101 KEYPAD REF SEL
1102 EXT1/EXT2 SEL
      EXT1
1103 REF1 SELECT
1104 REF1 MIN
EXIT      EDIT
  
```

- Press EDIT.
- Press UP/DOWN to step to the desired parameter value.

Note! To view the parameter default value: In the set mode, press UP/DOWN simultaneously.

- Press SAVE to store the modified value or press CANCEL to leave the set mode. Any modifications not saved are cancelled.
- Press EXIT to return to the listing of parameter groups, and again to return to the main menu.

```

LOC ↵ PAR EDIT—
1102 EXT1/EXT2 SEL
      EXT1
CANCEL  SAVE
  
```

Changed Parameters Mode

Use the Changed Parameters mode to view (and edit) a listing of all parameters that have been changed from macro default values.

Procedure:

1. Select CHANGED PAR in the Main Menu.
The display lists all changed parameters.
2. Press ENTER.
3. Press UP/DOWN to select a changed parameter.
As each parameter is highlighted, the parameter value appears.
4. Press EDIT to edit the parameter value.
5. Press UP/DOWN to select a new value / edit the parameter value. (Pressing both keys at the same time sets a parameter to its default value.)
6. Press SAVE to save the new parameter value. (If the new value is the default value, the parameter will no longer appear on the Changed Parameters listing.)

Fault Logger Mode

Use the Fault Logger Mode to see drive fault history, fault state details and help for the faults.

1. Select FAULT LOGGER in the Main Menu.
2. Press ENTER to see the latest faults (up to 10 faults, maximum).
3. Press DETAIL to see details for the selected fault.
Details are available for the three latest faults.
4. Press DIAG to see the help description for the fault. See "Diagnostics" section.

Note! If a power off occurs, only the three latest faults will remain (with details only for the most recent fault).

Par Backup Mode

The Assistant Control Panel can store a full set of drive parameters.

The Par Backup mode has these functions:

- **Upload to Panel** – Copies all parameters from the drive to the Control Panel. This includes user sets of parameters (if defined) and internal parameters. The Control Panel memory is non-volatile.
- **Download Full Set** – Restores the full parameter set from the Control Panel to the drive. Use this option to restore a drive, or to configure identical drives. This download does not include user sets of parameters.

Note! Download Full Set writes all parameters to the drive, including motor parameters. Only use this function to restore a drive, or to transfer parameters to systems that are identical to the original system.

- **Download Application** – Copies a partial parameter set from the Control Panel to a drive. The partial set does not include internal motor parameters, parameters 9905...9909, 1605, 1607, 5201, nor any Group 51 and 53 parameters. Use this option to transfer parameters to systems that use similar configurations – the drive and motor sizes do not need to be the same.
- **Download User Set 1** - Copies USER S1 parameters (user sets are saved using parameter 9902 APPLIC MACRO) from the Control Panel to the drive.
- **Download User Set 2** - Copies USER S2 parameters from the Control Panel to the drive.

The general procedure for parameter backup operations is:

1. Select PAR BACKUP in the Main Menu.
2. Press UP/DOWN to step to the desired option.
3. Press ENTER.

The parameter set is transferred as directed. During the transfer, the display shows the transfer status as a percent of completion.

4. Press EXIT to step back to the Output mode.

Handling Inexact Downloads

In some situations, an exact copy of the download is not appropriate for the target drive. Some examples:

- A download to an old drive specifies parameters/values that are not available on the old drive.
- A download (from an old drive) to a new drive does not have definitions for the new parameters – parameters that did not originally exist.
- A download can include an illegal value for the target drive, e.g. a backup from a small drive can have a switching frequency of 12 kHz whereas a big drive can only handle 8 kHz.



As a default, the control panel handles these situations by:

- Discarding parameters/values not available on the target drive.
- Using parameter default values when the download provides no values or invalid values.
- Providing a Differences List – A listing of the type and number of items that the target cannot accept exactly as specified.

LOC  DIFFERENCES ----	
VALUES UNDER MIN	3
VALUES OVER MAX	2
INVALID VALUES	1
EXTRA PARS	5
MISSING VALUES	7
READY	SEL

You can either accept the default edits by pressing READY, or view and edit each item as follows:

1. Highlight an item type in the Differences List (left screen below) and press SEL to see the details for the selected type (right screen below).

LOC  DIFFERENCES ----		LOC  INVALID VAL	
VALUES UNDER MIN	3	9902 APLIC MACRO	
VALUES OVER MAX	2	2606*SWITCHING FREQ	
INVALID VALUES	1	12 kHz	
EXTRA PARS	5	8 kHz	
MISSING VALUES	7	3401*DISP 1 SEL	
READY	SEL	EXIT	EDIT

In the above-right “details” screen:

- The first item that requires editing is automatically highlighted and includes details: In general, the first item listed in the details is the value defined by the backup file. The second item listed is the “default edit.”
 - For tracking purposes, an asterisk initially appears by each item. As edits are made, the asterisks disappear.
2. In the illustrated example, the backup specifies a switching frequency of 12 kHz, but the target drive is limited to 8 kHz.
 3. Press EDIT to edit the parameter. The display is the target drive’s standard edit screen for the selected parameter.
 4. Highlight the desired value for the target drive.
 5. Press SAVE to save setting.
 6. Press EXIT to step back to the differences view and continue for each remaining exception.
 7. When your editing is complete, press READY in the Differences List and then select “Yes, save parameters.”

Download Failures

In some situations, the drive may be unable to accept a download. In those cases, the control panel display is: “Parameter download failed” plus one of the following causes:

- Set not found – You are attempting to download a data set that was not defined in the backup. The remedy is to manually define the set, or upload the set from a drive that has the desired set definitions.
- Par lock – The remedy is to unlock the parameter set (parameter 1602).
- Incompat drive/model – The remedy is to perform backups only between drives of the same type (ACS/industrial or ACH/HVAC) and the same model (all ACS510).
- Too many differences – The remedy is to manually define a new set, or upload the set from a drive that more closely resembles the target drive.

I/O Settings Mode

Use the I/O Setting mode to check (and edit) the setting at any I/O terminal.

1. Select I/O SETTINGS in the Main Menu.

2. Press UP/DOWN to step to the desired I/O group, for example, digital inputs.
3. Press ENTER.
4. Press UP/DOWN to step to a particular item, for example DI1.
After a brief pause, the displays shows the current setting for the selection.
5. Press EDIT.
6. Press UP/DOWN to select a new setting.
7. Press SAVE to save.

Basic Control Panel

Features

The Basic Control Panel features:

- Numeric control panel with a LCD display.
- Drive connection that can be made or detached at any time
- Copy function – Parameters can be copied to the Control Panel memory for later transfer to other drives, or for backup of a particular system.

Controls/Display Overview

The following table summarizes the button functions and displays on the Basic Control Panel.

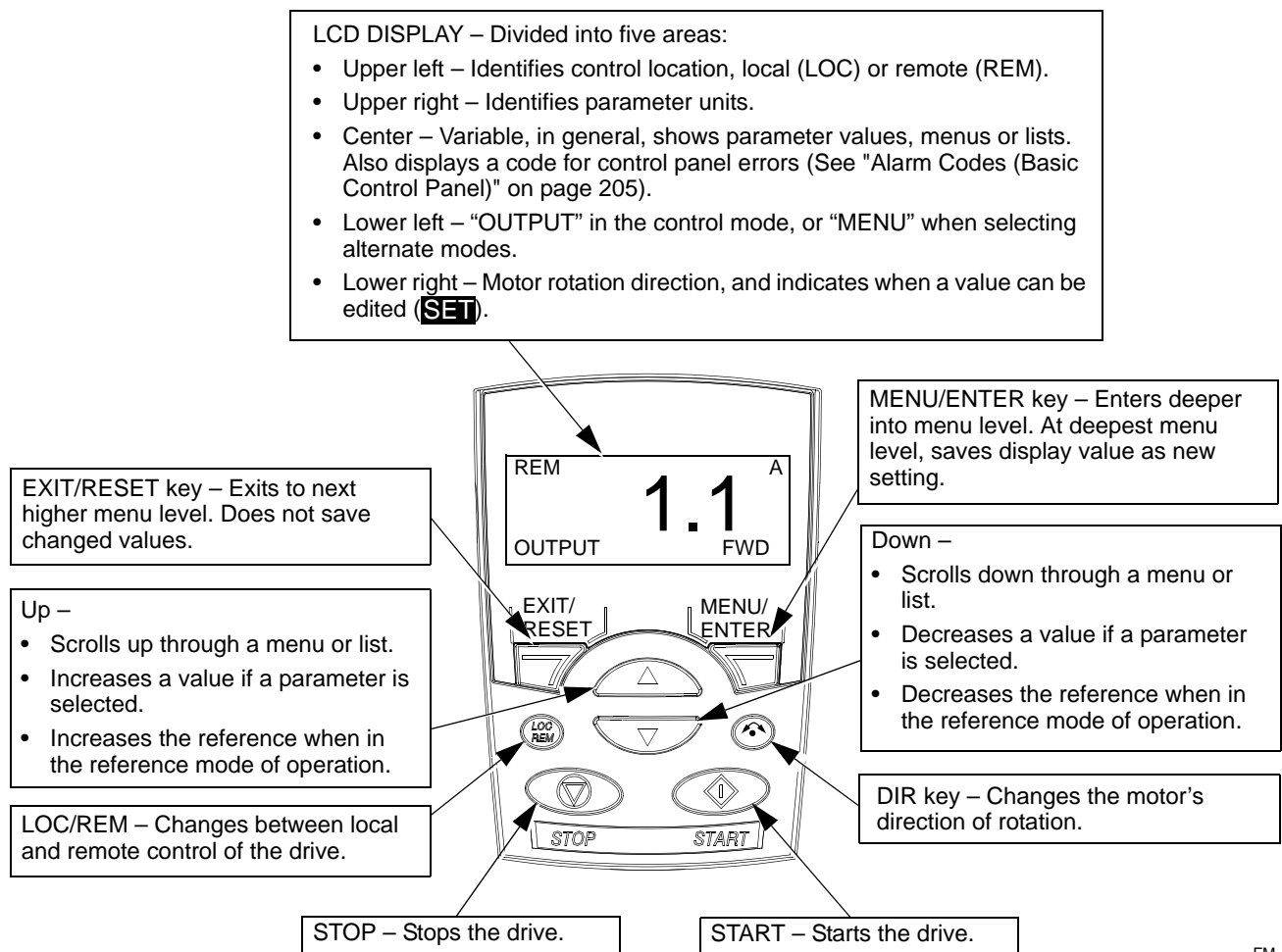

FM

Output Mode

Use the Output mode to read information on the drive's status and to operate the drive. To reach the Output mode, press EXIT/RESET until the display shows status information as described below.

Status Information

When the Basic Control Panel is in the Output mode, the display:

- Top-left shows the control location:
 - LOC – indicates that the drive control is local, that is, from the control panel.
 - REM – indicates that the drive control is remote, such as the basic I/O (X1) or fieldbus.
- The center of the display provides one Group 01 parameter value at a time, and makes up to three parameter values available (press UP or DOWN to scroll through available parameters).
 - By default, the display can scroll through three parameters 0103 (OUTPUT FREQUENCY), 0104 (CURRENT) and 0105 (TORQUE).
 - To change the defaults, use parameters 3401, 3408, and 3415 to select the parameters (from Group 01) in the scroll list. Enter value 0100 to disable any of the three items in the scroll list. For example, if 3401 = 0100 and 3415 = 0100, then scrolling is disabled and only the parameter specified by 3408 appears in the Control Panel display.
 - You can also scale each item in the scroll list, for example, to convert motor speed to a display of conveyor speed. Parameters 3402...3405 scale the parameter specified by 3401, parameters 3409...3412 scale the parameter specified by 3408, etc.
- Top-right shows the units for the parameter value.
- Bottom-left shows OUTPUT.
- Bottom-right shows the motor direction of rotation. Text display (FWD or REV) is:
 - Steady when the motor is up to speed
 - Flashing slowly when the motor is stopped.
 - Flashing quickly when the motor is accelerating.



Operating the Drive

LOC/REM – The very first time the drive is powered up, it is in the remote control (REM) mode, and is controlled from the Control Terminal Block X1.

To switch to local control (LOC) and control the drive using the control panel, press

 . If you:

- Press and release (the display flashes “LOC”), then: the drive stops. Use the Reference Mode to set the local control reference.
- Press and hold for about 2 seconds (release when the display changes from “LoC” to “LoC r”), then the drive continues as before. The drive copies the current remote values for run/stop status and the reference, and uses them as the initial local control commands.

To switch back to remote control (REM) press  .

Start/Stop – To start and stop the drive press the START and STOP buttons.

Shaft direction – To change the shaft direction press DIR ↕ (parameter 1003 must be set to 3 (REQUEST)).

Reference – See "Reference Mode" below.

Reference Mode

Use the Reference Mode to set the frequency reference. Normally this reference control is only possible when the drive is under Local (LOC) control. However, the drive can be set up (using Group 11: Reference Select) to also allow reference modification when the drive is under remote (REM) control.

1. Starting from the Output mode, press MENU/ENTER.

The display shows one of the following alternate modes:

- reF (Reference)
- PAr (Parameter)
- CoPY (Copy)

2. Use UP or DOWN arrow key to step through to the "reF" (Reference Mode).
3. Press MENU/ENTER.

The display shows the current reference value with **SET** under the value.

Note! Normally, reference adjustment is only possible here when under LOC control, but settings in Group 11, do allow reference adjustments under REM control. The **SET** display indicates when reference adjustment is possible at the control panel.

4. Use UP or DOWN arrow key to step to the desired reference value.
5. Press EXIT/RESET to step back to the Output mode.

Parameters Mode

Use the Parameter Mode to set parameter values.

1. Starting from the Output mode, press MENU/ENTER.

The display shows one of the following alternate modes:

- reF (Reference)
- PAr (Parameter)
- CoPY (Copy)

2. Use UP or DOWN arrow key to step through to the "PAr" (Parameter Mode).
3. Press MENU/ENTER.

The display shows one of the parameter groups:

- "01"
- ...
- "99"

4. Use UP or DOWN arrow key to step through to the desired group, for example "03".
5. Press MENU/ENTER.

The display shows one of the parameters in the selected parameter group. For example, "0301".

6. Use UP or DOWN arrow key to step through to the desired parameter.
7. Press MENU/ENTER, either:

- Press and hold for about 2 seconds or
- Press the key twice in quick succession

The display shows the value of the selected parameter with **SET** under the value.

Note! Briefly pressing the MENU/ENTER key displays the parameter's current value for about 2 seconds. During this display, pressing the MENU/ENTER key again also enables **SET**.

8. Use UP or DOWN arrow key to step to the desired parameter value.

Note! In **SET**, pressing the UP and DOWN arrow keys simultaneously displays the default parameter value.

9. In **SET**, press MENU/ENTER to save the parameter value being displayed.

Note! If, instead, you press EXIT/RESET the original, or last saved, parameter value is the active value.

10. Press EXIT/RESET to step back to the Output mode.

Par Backup Mode

The Basic Control Panel can store a full set of drive parameters. If two sets of parameters are defined, both are copied and transferred when using this feature.

The Par Backup mode has three functions:

- uL (Upload) – Copies all parameters from the drive to the Control Panel. This includes a second set of parameters (if defined) and internal parameters. The Control Panel memory is non-volatile.
- rE A (Restore All) – Restores the full parameter set(s) from the Control Panel to the drive. Use this option to restore a drive, or to configure identical drives.

Note! The Restore All function writes all parameters to the drive, including motor parameters. Only use this function to restore a drive, or to transfer parameters to systems that are identical to the original system.

- dL P (Download Partial) – Copies a partial parameter set from the Control Panel to a drive. The partial set does not include internal motor parameters, parameters 9905...9909, 1605, 1607, 5201, nor any Group 51 and Group 53 parameters. Use this option to transfer parameters to systems that use similar configurations – the drive and motor sizes do not need to be the same.
 - dL u1 (Download User Set 1) – Copies USER S1 parameters (user sets are saved using parameter 9902 APPLIC MACRO) from the Control Panel to the drive.
 - dl u2 (Download User Set 2) – Copies USER S2 parameters from the Control Panel to the drive.
1. Starting from the Output mode, press MENU/ENTER.
The display shows one of the following alternate modes:
 - reF (Reference)
 - PAr (Parameter)
 - CoPY (Copy)
 2. Use UP or DOWN arrow key to step through to the “CoPY” (Copy) Mode.
 3. Press MENU/ENTER.
The display shows one of the following copy options:
 - uL (Upload)
 - rE A (Restore All)
 - dL P (Download Partial)
 4. Use UP or DOWN arrow key to step to the desired option.
 5. Press MENU/ENTER.
The parameter set is transferred as directed. During the transfer, the display shows the transfer status as a percent of completion.
 6. Press EXIT/RESET to step back to the Output mode.

Handling Inexact Downloads

In some situations, an exact copy of the download is not appropriate for the target drive. The Basic control panel automatically handles these situations by:

- Discarding parameters/values not available on the target drive.
- Using parameter default values when the download provides no values or invalid values.

Alarm Codes

The Basic Control Panel indicates Control Panel alarms with a code of the form A5xxx. See "Alarm Codes (Basic Control Panel)" on page 205 for a list of the alarm codes and descriptions.

Application Macros

Macros change a group of parameters to new, predefined values. Use macros to minimize the need for manual editing of parameters. Selecting a macro sets all other parameters to their default values, except:

- Group 99: Start-Up Data parameters
- 1602 PARAMETER LOCK
- 1607 PARAM SAVE
- 3018 COMM FAULT FUNC and 3019 COMM FAULT TIME
- 9802 COMM PROT SEL
- Groups 51...53 parameters

After selecting a macro, additional parameter changes can be made manually using the control panel.

Application macros are enabled by setting the value for parameter 9902 APPLIC MACRO. By default, 1, ABB Standard, is the enabled macro.

The following sections describe each of the application macros and provide a connection example for each macro.

The last section below, "Macro Default Values for Parameters" lists the parameters that the macros change, and the default values established by each macro.

Application Macro: ABB Standard (Default)

This macro provides a general purpose, 2-wire I/O configuration, with three (3) constant speeds. This is the default macro. Parameter values are the default values defined in the "Complete Parameter List for ACS510" on page 52.

Connection example:

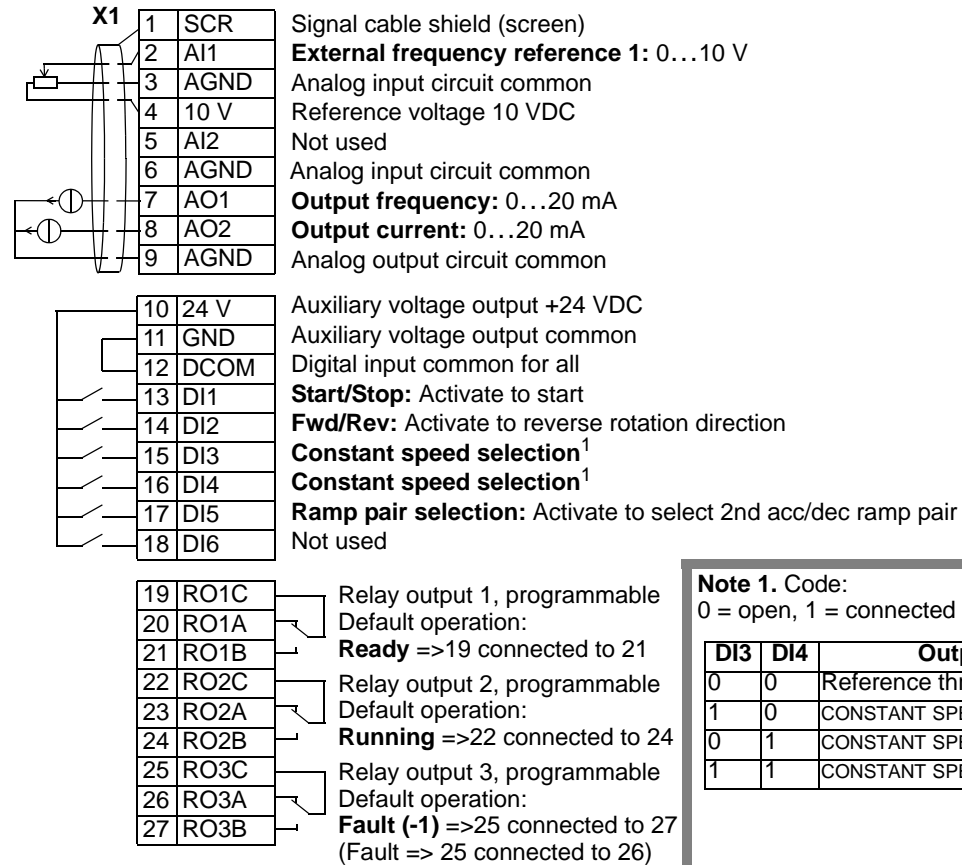

Note 1. Code:
0 = open, 1 = connected

DI3	DI4	Output
0	0	Reference through AI1
1	0	CONSTANT SPEED 1 (1202)
0	1	CONSTANT SPEED 2 (1203)
1	1	CONSTANT SPEED 3 (1204)

Input signals

- Analog reference (AI1)
- Start, stop and direction (DI1,2)
- Constant speed selection (DI3,4)
- Ramp pair (1 of 2) selection (DI5)

Output signals

- Analog output AO1: Frequency
- Analog output AO2: Current
- Relay output 1: Ready
- Relay output 2: Running
- Relay output 3: Fault (-1)

Jumper Setting

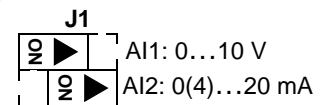

Application Macro: 3-wire

This macro is used when the drive is controlled using momentary push-buttons, and provides three (3) constant speeds. To enable, set the value of parameter 9902 to 2 (3-WIRE).

Note! When the stop input (DI2) is deactivated (no input), the control panel start/stop buttons are disabled.

Connection example:

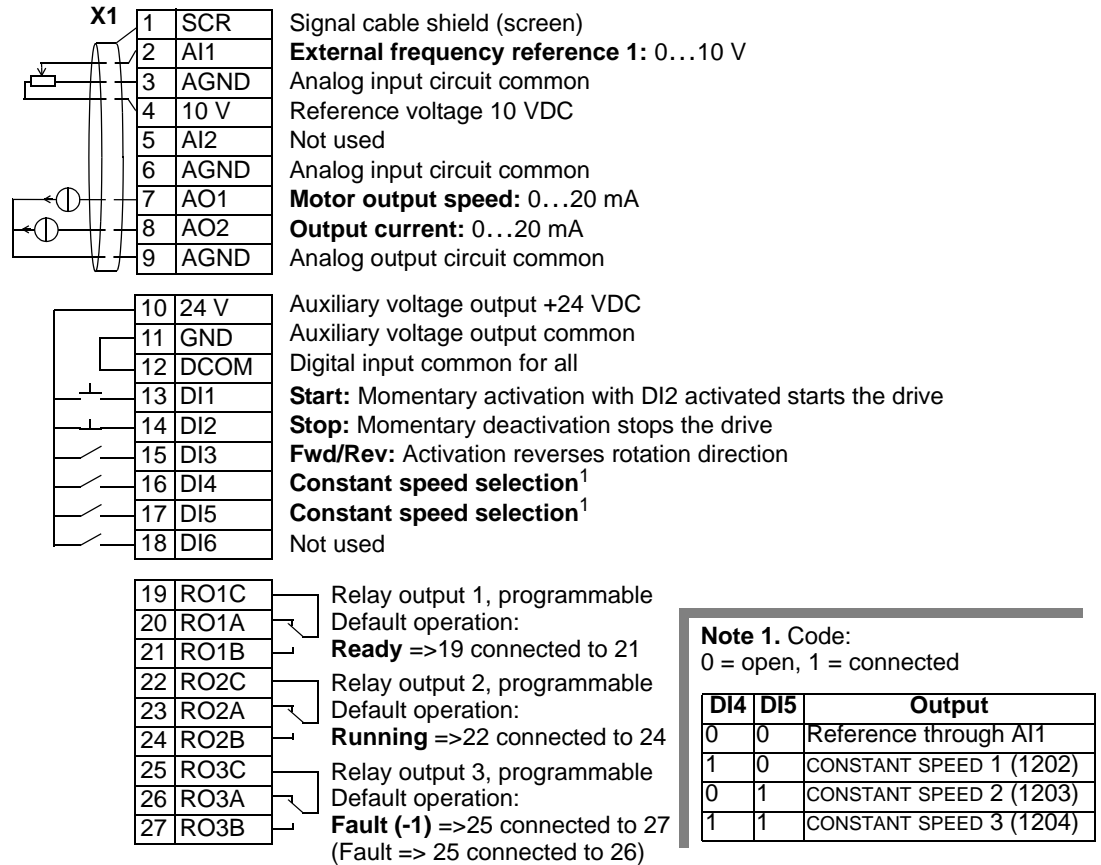

Input signals

- Analog reference (AI1)
- Start, stop and direction (DI1,2,3)
- Constant speed selection (DI4,5)

Output signals

- Analog output AO1: Speed
- Analog output AO2: Current
- Relay output 1: Ready
- Relay output 2: Running
- Relay output 3: Fault (-1)

Jumper Setting

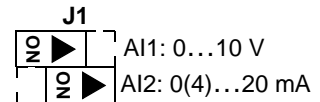

Application Macro: Alternate

This macro provides an I/O configuration adopted to a sequence of DI control signals used when alternating the rotation direction of the drive. To enable, set the value of parameter 9902 to 3 (ALTERNATE).

Connection example:

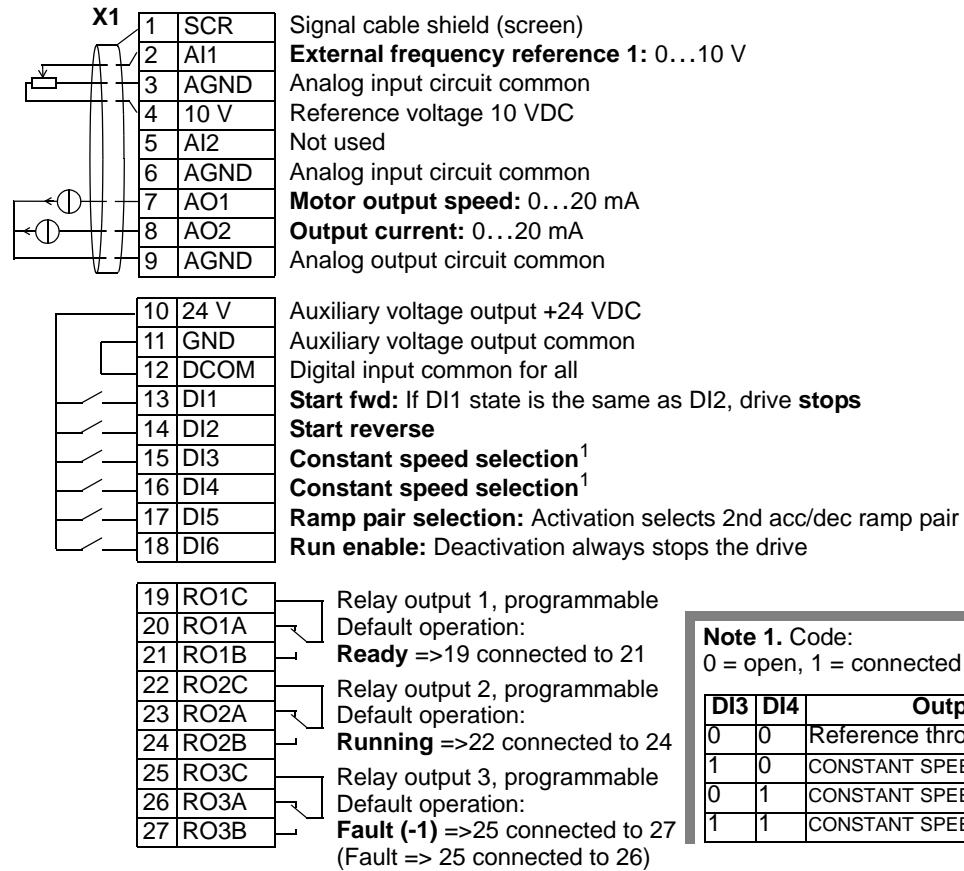

Input signals

- Analog reference (AI1)
- Start, stop and direction (DI1,2)
- Constant speed selection (DI3,4)
- Ramp pair 1/2 selection (DI5)
- Run enable (DI6)

Output signals

- Analog output AO1: Speed
- Analog output AO2: Current
- Relay output 1: Ready
- Relay output 2: Running
- Relay output 3: Fault (-1)

Jumper Setting

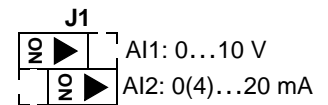

Application Macro: Motor Potentiometer

This macro provides a cost-effective interface for PLCs that vary the speed of the drive using only digital signals. To enable, set the value of parameter 9902 to 4 (MOTOR POT).

Connection example:

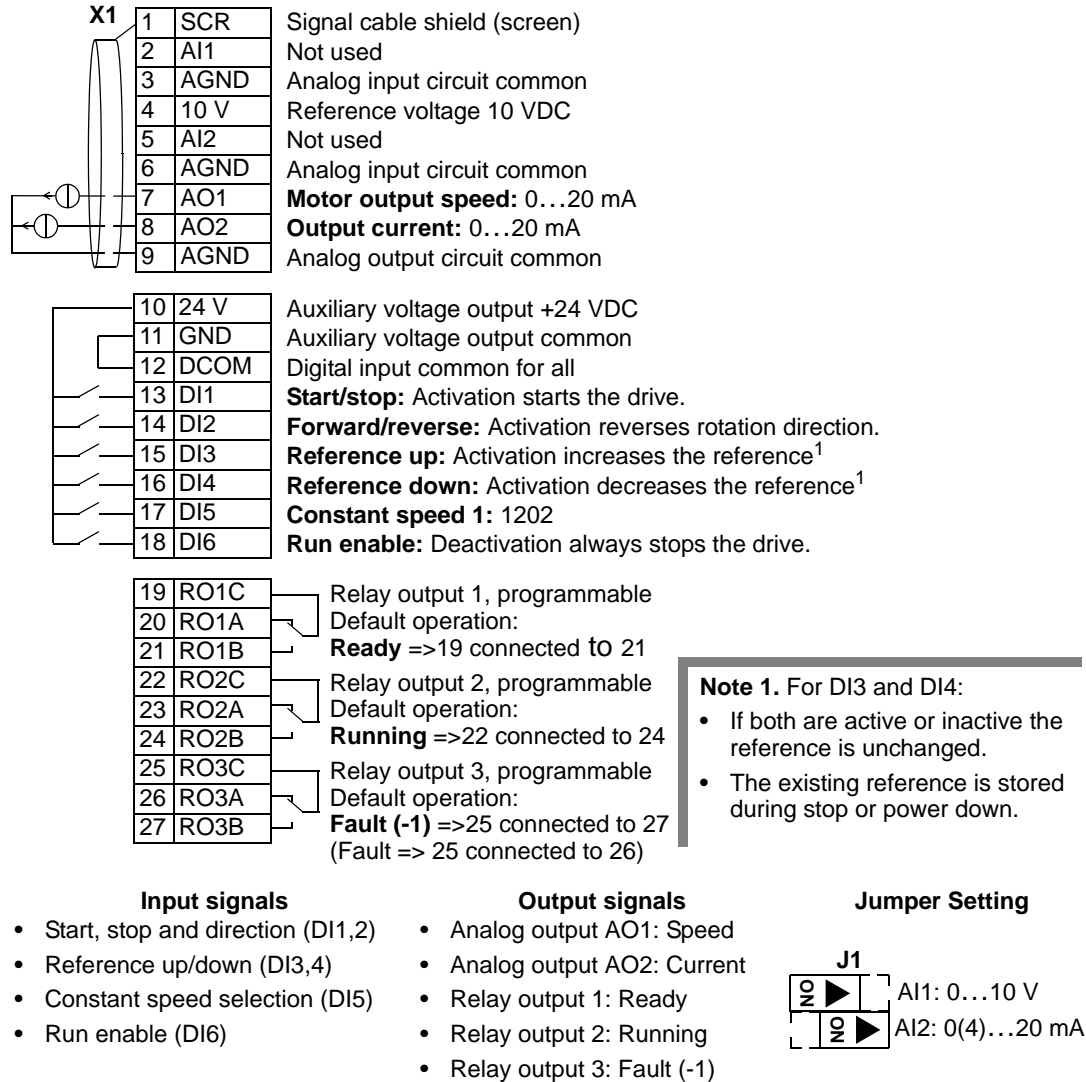

Application macro: Hand-Auto

This macro provides an I/O configuration that is typically used in HVAC applications. To enable, set the value of parameter 9902 to 5 (HAND/AUTO).

Note! Parameter 2108 START INHIBIT must remain in the default setting, 0 (OFF).

Connection example:

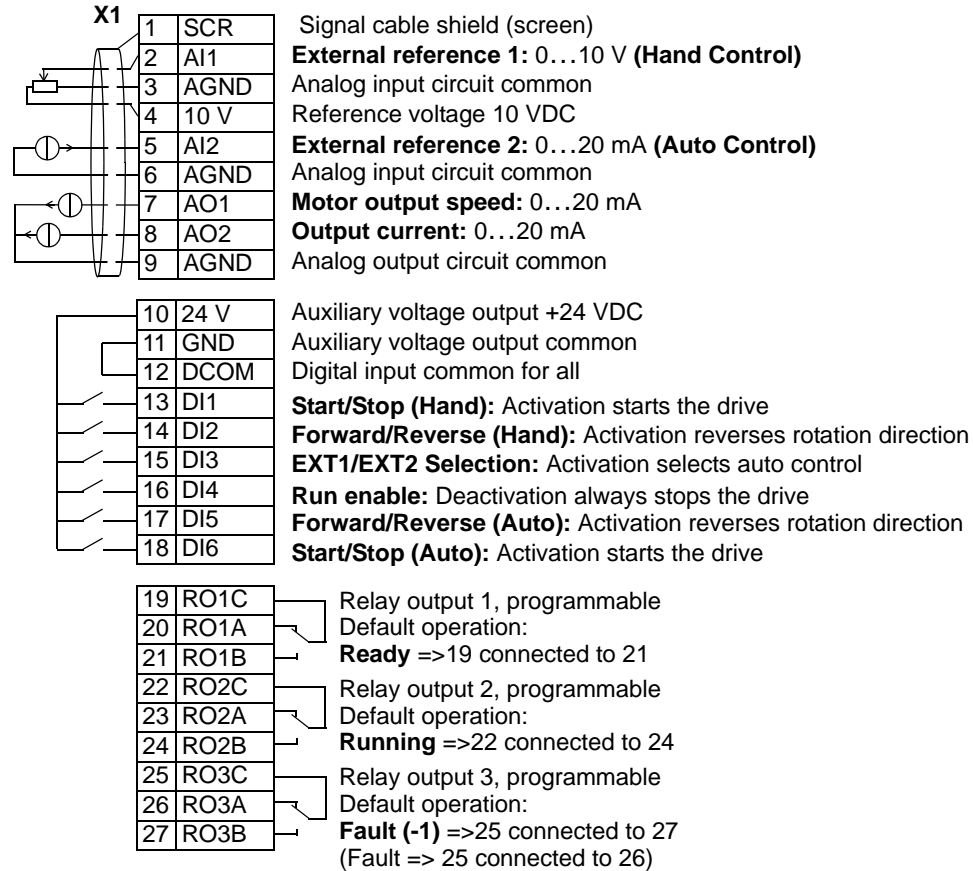

Input signals

- Two analog references (AI1, 2)
- Start/stop – hand/auto (DI1, 6)
- Direction – hand/auto (DI2, 5)
- Control location selection (DI3)
- Run enable (DI4)

Output signals

- Analog output AO1: Speed
- Analog output AO2: Current
- Relay output 1: Ready
- Relay output 2: Running
- Relay output 3: Fault (-1)

Jumper Setting

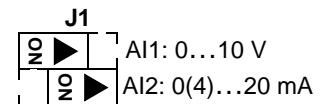

Application Macro: PID Control

This macro provides parameter settings for closed-loop control systems such as pressure control, flow control, etc. To enable, set the value of parameter 9902 to 6 (PID CTRL).

Note! Parameter 2108 START INHIBIT must remain in the default setting, 0 (OFF).

Connection example:

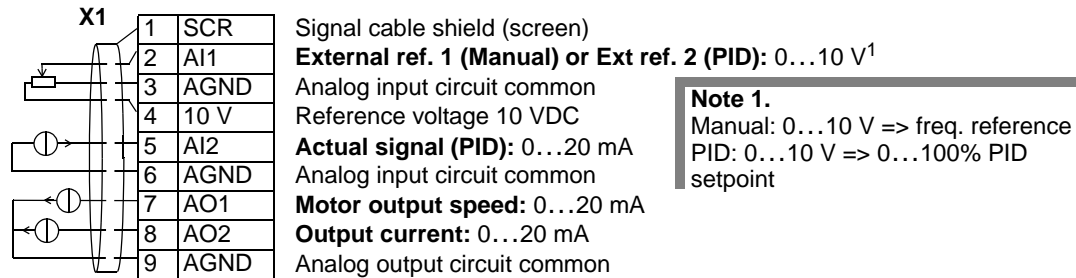

Note 1.
Manual: 0...10 V => freq. reference
PID: 0...10 V => 0...100% PID setpoint

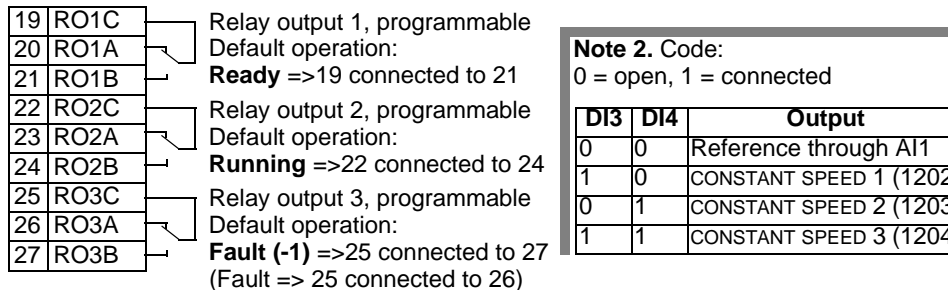
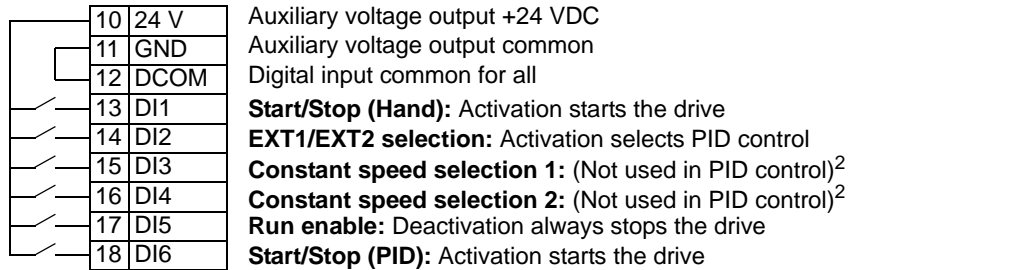

Note 2. Code:
0 = open, 1 = connected

DI3	DI4	Output
0	0	Reference through AI1
1	0	CONSTANT SPEED 1 (1202)
0	1	CONSTANT SPEED 2 (1203)
1	1	CONSTANT SPEED 3 (1204)

- | | |
|--|---|
| <p>Input signals</p> <ul style="list-style-type: none"> • Analog reference (AI1) • Actual value (AI2) • Start/stop – hand/PID (DI1, 6) • EXT1/EXT2 selection (DI2) • Constant speed selection (DI3, 4) • Run enable (DI5) | <p>Output signals</p> <ul style="list-style-type: none"> • Analog output AO1: Speed • Analog output AO2: Current • Relay output 1: Ready • Relay output 2: Running • Relay output 3: Fault (-1) |
|--|---|

Jumper Setting

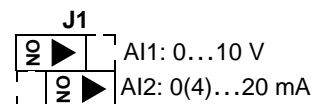

Application Macro: PFC

This macro provides parameter settings for pump and fan control (PFC) applications. To enable, set the value of parameter 9902 to 7 (PFC CONTROL).

Note! Parameter 2108 START INHIBIT must remain in the default setting, 0 (OFF).

Connection example:

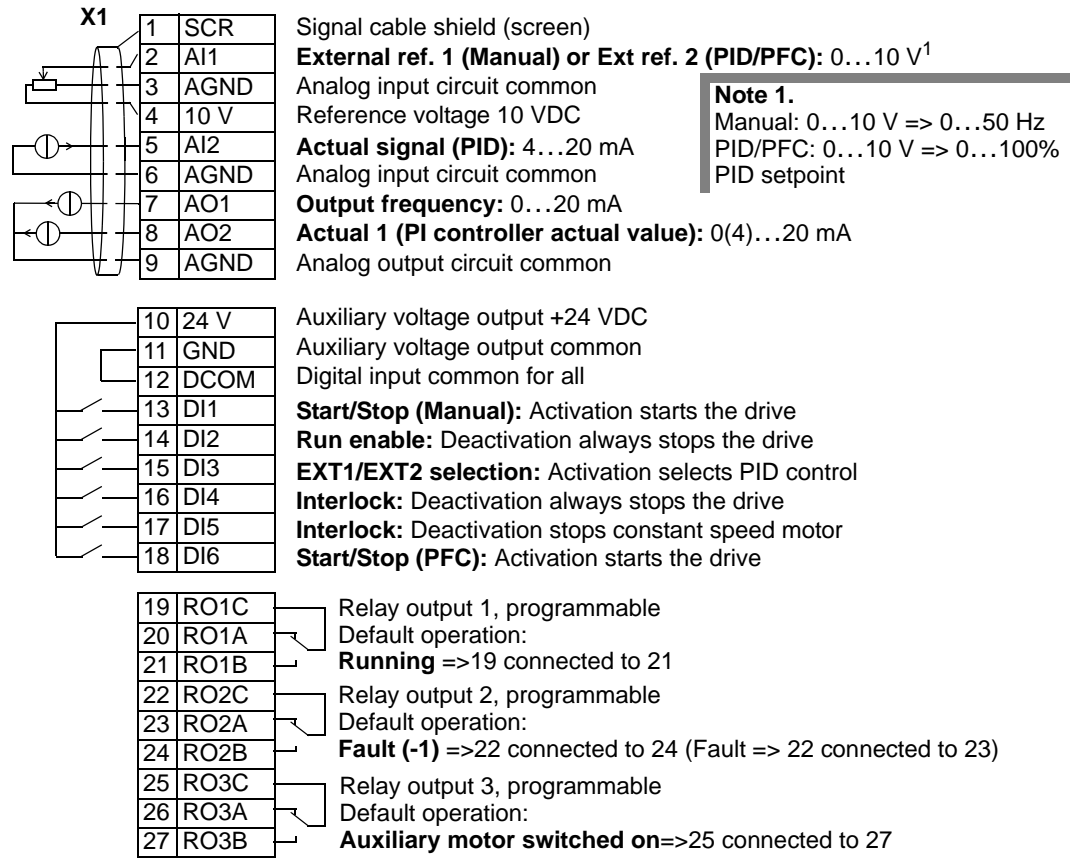

Note 1.
Manual: 0...10 V => 0...50 Hz
PID/PFC: 0...10 V => 0...100%
PID setpoint

- Input signals**
- Analog ref. and actual (AI1, 2)
 - Start/stop – manual/PFC (DI1, 6)
 - Run enable (DI2)
 - EXT1/EXT2 selection (DI3)
 - Interlock (DI4, 5)

- Output signals**
- Analog output AO1: Frequency
 - Analog output AO2: Actual 1
 - Relay output 1: Running
 - Relay output 2: Fault (-1)
 - Relay output 3: Aux. motor ON

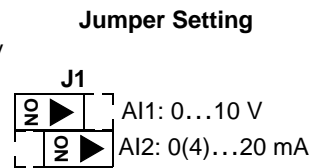

Application Macro: SPFC

This macro provides parameter settings for pump and fan control (PFC) applications with cycle soft start function. To enable, set the value of parameter 9902 to 15 (SPFC CONTROL).

Note! Parameter 2108 START INHIBIT must remain in the default setting, 0 (OFF).

Connection example:

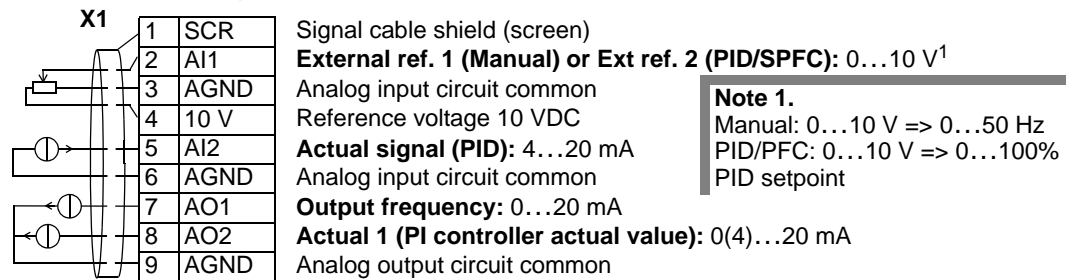

Note 1.
 Manual: 0...10 V => 0...50 Hz
 PID/PFC: 0...10 V => 0...100%
 PID setpoint

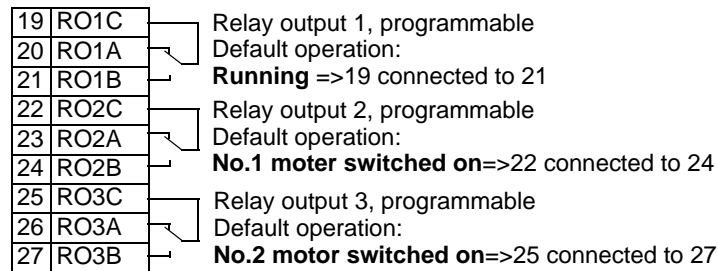
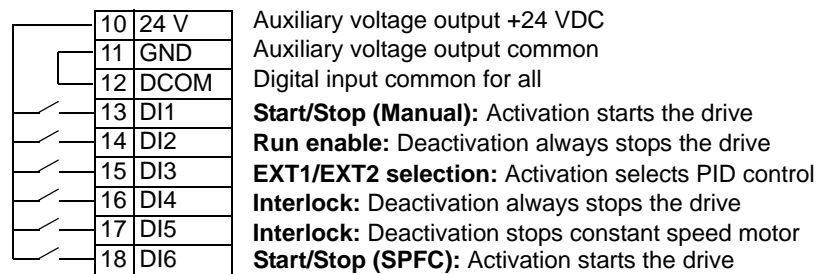

- Input signals**
- Analog ref. and actual (AI1, 2)
 - Start/stop – manual/PFC (DI1, 6)
 - Run enable (DI2)
 - EXT1/EXT2 selection (DI3)
 - Interlock (DI4, 5)

- Output signals**
- Analog output AO1: Frequency
 - Analog output AO2: Actual 1
 - Relay output 1: Running
 - Relay output 2: Fault (-1)
 - Relay output 3: Aux. motor ON

Jumper Setting

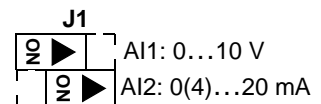

Macro Default Values for Parameters

Parameter default values are listed in "Complete Parameter List for ACS510". Changing from the default macro (ABB Standard), that is, editing the value of parameter 9902, changes the parameter default values as defined in the following tables.

ACS510-01

Parameter		ABB Standard	3-wire	Alternate	Motor Potentiometer	Hand-auto	PID Control	PFC Control	SPFC Control
9902	APPLIC MACRO	1	2	3	4	5	6	7	15
1001	EXT1 COMMANDS	2	4	9	2	2	1	1	1
1002	EXT2 COMMANDS	0	0	0	0	7	6	6	6
1003	DIRECTION	3	3	3	3	3	1	1	1
1102	EXT1/EXT2 SEL	0	0	0	0	3	2	3	3
1103	REF1 SELECT	1	1	1	12	1	1	1	1
1106	REF2 SELECT	2	2	2	2	2	19	19	19
1201	CONST SPEED SEL	9	10	9	5	0	9	0	0
1304	MINIMUM AI2	0	0	0	0	20	20	20	20
1401	RELAY OUTPUT 1	1	1	1	1	1	1	2	2
1402	RELAY OUTPUT 2	2	2	2	2	2	2	3	31
1403	RELAY OUTPUT 3	3	3	3	3	3	3	31	31
1501	AO1 CONTENT SEL	103	102	102	102	102	102	103	103
1503	AO1 CONTENT MAX	50	50	50	50	50	50	52	52
1507	AO2 CONTENT SEL	104	104	104	104	104	104	130	130
1510	MINIMUM AO2	0	0	0	0	0	0	4	4
1601	RUN ENABLE	0	0	6	6	4	5	2	2
2008	MAXIMUM FREQ	50	50	50	50	50	50	52	52
2201	ACC/DEC 1/2 SEL	5	0	5	0	0	0	0	0
3201	SUPERV 1 PARAM	103	102	102	102	102	102	103	103
3401	SIGNAL 1 PARAM	103	102	102	102	102	102	103	103
4001	GAIN	2.5	2.5	2.5	2.5	2.5	2.5	25	2.5
4002	INTEGRATION TIME	3	3	3	3	3	3	3	3
4101	GAIN	1	1	1	1	1	1	2,5	2,5
4102	INTEGRATION TIME	60	60	60	60	60	60	3	3
8118	AUTOCHG INTERV	0	0	0	0	0	0	0	0,1
8123	PFC ENABLE	0	0	0	0	0	0	1	2

* This parameter is not available in software option +N688 and +N689.

Complete Parameter List for ACS510

The following table lists all parameters. Table header abbreviations are:

- S = Parameters can be modified only when the drive is stopped.
- User = Space to enter desired parameter values

Some values vary depending on the drive software options. This is indicated by "+N688:" or "+N689" in the table below. Refer to the type code on the drive nameplate. For example ACS510-01...+N688 .

Code	Name	Range	Resolution	Default	User	S
Group 99: Start-Up Data						
9901	LANGUAGE	0...3	1	0		
9902	APPLIC MACRO	-3...7, 15	1	1		✓
9905	MOTOR NOM VOLT	200...600 V /	1 V	400 V		✓
9906	MOTOR NOM CURR	0.2*I _{2n} ...2.0*I _{2n}	0.1 A	1.0*I _{2n}		✓
9907	MOTOR NOM FREQ	10.0...500.0 Hz / +N688:10.0...50.0 Hz / +N689:10.0...55.0 Hz	0.1 Hz	50.0 Hz / +N688:50.0 Hz / +N689:55.0 Hz		✓
9908	MOTOR NOM SPEED	50...30,000 rpm	1 rpm	Size dependent		✓
9909	MOTOR NOM POWER	0.2...3.0*P _n	0.1 kW	1.0 * P _n		✓
Group 01: Operating Data						
0101	SPEED & DIR	-30000...30000 rpm	1 rpm	-		
0102	SPEED	0...30000 rpm	1 rpm	-		
0103	OUTPUT FREQ	0.0...500.0 Hz / +N688:0.0...50.0 Hz / +N689:0.0...55.0 Hz	0.1 Hz	-		
0104	CURRENT	0...2.0*I _{2n}	0.1 A	-		
0105	TORQUE	-200.0...200.0%	0.1%	-		
0106	POWER	-2.0...2.0*P _n	0.1 kW	-		
0107	DC BUS VOLTAGE	0...2.5*V _{dN}	1 V	-		
0109	OUTPUT VOLTAGE	0...2.0*V _{dN}	1 V	-		
0110	DRIVE TEMP	0.0...150.0 °C	0.1 °C	-		
0111	EXTERNAL REF 1	0.0...500.0 Hz / +N688:0.0...50.0 Hz / +N689:0.0...55.0 Hz	0.1 Hz	-		
0112	EXTERNAL REF 2	0.0...100.0%	0.1%	-		
0113	CTRL LOCATION	0 = local, 1 = ext1, 2 = ext2	1	-		
0114	RUN TIME (R)	0...9999 h	1 h	0 h		
0115	KWH COUNTER (R)	0...9999 kWh	1 kWh	-		
0116	APPL BLK OUTPUT	0.0...100.0%	0.1%	-		
0118	DI 1-3 STATUS	000...111 (0...7 decimal)	1	-		
0119	DI 4-6 STATUS	000...111 (0...7 decimal)	1	-		
0120	AI1	0.0...100.0%	0.1%	-		
0121	AI2	0.0...100.0%	0.1%	-		
0122	RO 1-3 STATUS	000...111 (0...7 decimal)	1	-		
0123	RO 4-6 STATUS	000...111 (0...7 decimal)	1	-		
0124	AO1	0.0...20.0 mA	0.1 mA	-		

Code	Name	Range	Resolution	Default	User	S
0125	AO2	0.0...20.0 mA	0.1 mA	-		
0126	PID 1 OUTPUT	-1000.0...1000.0%	0.1%	-		
0127	PID 2 OUTPUT	-100.0...100.0%	0.1%	-		
0128	PID 1 SETPNT	Unit and scale defined by par. 4006/ 4106 and 4007/4107	-	-		
0129	PID 2 SETPNT	Unit and scale defined by par. 4206 and 4207				
0130	PID 1 FBK	Unit and scale defined by par. 4006/ 4106 and 4007/4107	-	-		
0131	PID 2 FBK	Unit and scale defined by par. 4206 and 4207	-	-		
0132	PID 1 DEVIATION	Unit and scale defined by par. 4006/ 4106 and 4007/4107	-	-		
0133	PID 2 DEVIATION	Unit and scale defined by par. 4206 and 4207	-	-		
0134	COMM RO WORD	0...65535	1	0		
0135	COMM VALUE 1	-32768...+32767	1	0		
0136	COMM VALUE 2	-32768...+32767	1	0		
0137	PROCESS VAR 1	-	1			
0138	PROCESS VAR 2	-	1			
0139	PROCESS VAR 3	-	1			
0140	RUN TIME	0.00...499.99 kh	0.01 kh	0 kh		
0141	MWH COUNTER	0...9999 MWh	1 MWh	-		
0142	REVOLUTION CNTR	0...65535 Mrev	1 Mrev	0		
0143	DRIVE ON TIME HI	0...65535 Days	1 day	0		
0144	DRIVE ON TIME LO	hh.mm.ss	1 = 2s	0		
0145	MOTOR TEMP	-10...200 °C/ 0...5000 Ohm / 0...1	1	0		
0146... 0148	Not used					
0149	OVERRIDE ACTIVED	0..1	1	0		
0150	CB TEMP	-20.0 ... 150.0 °C	1.0 °C	-		
0151	INPUT KWH (R)	0.0 ... 999.9 kWh	1.0 kWh	-		
0152	INPUT MWH	0 ... 9999 MWh	1 MWh	-		
0158	PID COMM VALUE 1	-32768 ... +32767	1	-		
0159	PID COMM VALUE 2	-32768 ... +32767	1	-		
Group 03: FB Actual Signals						
0301	FB CMD WORD 1	-	-	-		
0302	FB CMD WORD 2	-	-	-		
0303	FB STS WORD 1	-	-	-		
0304	FB STS WORD 2	-	1	0		
0305	FAULT WORD 1	-	1	0		
0306	FAULT WORD 2	-	1	0		
0307	FAULT WORD 3	-	1	0		
0308	ALARM WORD 1	-	1	0		
0309	ALARM WORD 2	-	1	0		
Group 04: Fault History						
0401	LAST FAULT	Fault codes (panel displays as text)	1	0		

Code	Name	Range	Resolution	Default	User	S
0402	FAULT TIME 1	Date dd.mm.yy / power-on time in days	1 day	0		
0403	FAULT TIME 2	Time hh.mm.ss	2 s	0		
0404	SPEED AT FLT	-32768 ... +32767	1 rpm	0		
0405	FREQ AT FLT	-3276.8 ... +3276.7	0.1 Hz	0		
0406	VOLTAGE AT FLT	0.0 ... 6553.5	0.1 V	0		
0407	CURRENT AT FLT	0.0 ... 6553.5	0.1 A	0		
0408	TORQUE AT FLT	-3276.8 ... +3276.7	0.1%	0		
0409	STATUS AT FLT	0 ... 0xFFFF (hex)	1	0		
0410	DI 1-3 AT FLT	000...111 (0...7 decimal)	1	0		
0411	DI 4-6 AT FLT	000...111 (0...7 decimal)	1	0		
0412	PREVIOUS FAULT 1	As Par. 0401	1	0		
0413	PREVIOUS FAULT 2	As Par. 0401	1	0		
Group 10: Start/Stop/Dir						
1001	EXT1 COMMANDS	0...10	1	2 +N688:1 +N689:1		✓
1002	EXT2 COMMANDS	0...10	1	0		✓
1003 (NOTE)	DIRECTION	1...3	1	3		✓
Group 11: Reference Select						
1101	KEYPAD REF SEL	1...2	1	1		
1102	EXT1/EXT2 SEL	-6...8	1	0		✓
1103	REF1 SELECT	0...17, 20...21	1	1		✓
1104	REF1 MIN	0.0...500.0 Hz / +N688:0.0...50.0 Hz / +N689:0.0...55.0 Hz	0.1 Hz	0.0 Hz		
1105	REF1 MAX	0.0...500.0 Hz / +N688:0.0...50.0 Hz / +N689:0.0...55.0 Hz	0.1 Hz	50.0 Hz / +N688:50.0 Hz / +N689:55.0 Hz		
1106	REF2 SELECT	0...17, 19...21	1	2		✓
1107	REF2 MIN	0.0...100.0%	0.1%	0.0%		
1108	REF2 MAX	0.0...100.0%	0.1%	100.0%		
Group 12: Constant Speeds						
1201	CONST SPEED SEL	-14 ... 14	1	9		✓
1202	CONST SPEED 1	0.0...500.0 Hz / +N688:0.0...50.0 Hz / +N689:0.0...55.0 Hz	0.1 Hz	5.0 Hz / +N688:5.0 Hz / +N689:5.5Hz		
1203	CONST SPEED 2	0.0...500.0 Hz / +N688:0.0...50.0 Hz / +N689:0.0...55.0 Hz	0.1 Hz	10.0 Hz / +N688:10.0 Hz / +N689:11.0 Hz		
1204	CONST SPEED 3	0.0...500.0 Hz / +N688:0.0...50.0 Hz / +N689:0.0...55.0 Hz	0.1 Hz	15.0 Hz / +N688:15.0 Hz / +N689:16.5Hz		
1205	CONST SPEED 4	0.0...500.0 Hz / +N688:0.0...50.0 Hz / +N689:0.0...55.0 Hz	0.1 Hz	20.0 Hz / +N688:20.0 Hz / +N689:22.0 Hz		

Code	Name	Range	Resolution	Default	User	S
1206	CONST SPEED 5	0.0...500.0 Hz / +N688:0.0...50.0 Hz / +N689:0.0...55.0 Hz	0.1 Hz	25.0 Hz / +N688:25.0 Hz / +N689:27.5Hz		
1207	CONST SPEED 6	0.0...500.0 Hz / +N688:0.0...50.0 Hz / +N689:0.0...55.0 Hz	0.1 Hz	40.0 Hz / +N688:40.0 Hz / +N689:44.0 Hz		
1208	CONST SPEED 7	0.0...500.0 Hz / +N688:0.0...50.0 Hz / +N689:0.0...55.0 Hz	0.1 Hz	50.0 Hz / +N688:50.0 Hz / +N689:55.0 Hz		
Group 13: Analogue Inputs						
1301	MINIMUM AI1	0.0...100.0%	0.1%	0.0%		
1302	MAXIMUM AI1	0.0...100.0%	0.1%	100.0%		
1303	FILTER AI1	0.0...10.0 s	0.1 s	0.1 s		
1304	MINIMUM AI2	0.0...100.0%	0.1%	0.0%		
1305	MAXIMUM AI2	0.0...100.0%	0.1%	100.0%		
1306	FILTER AI2	0.0...10.0 s	0.1 s	0.1 s		
Group 14: Relay Outputs						
1401	RELAY OUTPUT 1	0...36, 45...47	1	1		
1402	RELAY OUTPUT 2	0...36, 45...47	1	2		
1403	RELAY OUTPUT 3	0...36, 45...47	1	3		
1404	RO 1 ON DELAY	0.0...3600.0 s	0.1 s	0.0 s		
1405	RO 1 OFF DELAY	0.0...3600.0 s	0.1 s	0.0 s		
1406	RO 2 ON DELAY	0.0...3600.0 s	0.1 s	0.0 s		
1407	RO 2 OFF DELAY	0.0...3600.0 s	0.1 s	0.0 s		
1408	RO 3 ON DELAY	0.0...3600.0 s	0.1 s	0.0 s		
1409	RO 3 OFF DELAY	0.0...3600.0 s	0.1 s	0.0 s		
1410	RELAY OUTPUT 4	0...36, 45...47	1	0		
1411	RELAY OUTPUT 5	0...36, 45...47	1	0		
1412	RELAY OUTPUT 6	0...36, 45...47	1	0		
1413	RO 4 ON DELAY	0.0...3600.0 s	0.1 s	0.0 s		
1414	RO 4 OFF DELAY	0.0...3600.0 s	0.1 s	0.0 s		
1415	RO 5 ON DELAY	0.0...3600.0 s	0.1 s	0.0 s		
1416	RO 5 OFF DELAY	0.0...3600.0 s	0.1 s	0.0 s		
1417	RO 6 ON DELAY	0.0...3600.0 s	0.1 s	0.0 s		
1418	RO 6 OFF DELAY	0.0...3600.0 s	0.1 s	0.0 s		
Group 15: Analogue Outputs						
1501	AO1 CONTENT SEL	99...159	1	103		
1502	AO1 CONTENT MIN	-	-	Defined by par. 0103		
1503	AO1 CONTENT MAX	-	-	Defined by par. 0103		
1504	MINIMUM AO1	0.0...20.0 mA	0.1 mA	0.0 mA		
1505	MAXIMUM AO1	0.0...20.0 mA	0.1 mA	20.0 mA		
1506	FILTER AO1	0.0...10.0 s	0.1 s	0.1 s		
1507	AO2 CONTENT SEL	99...159	1	104		
1508	AO2 CONTENT MIN	-	-	Defined by par. 0104		
1509	AO2 CONTENT MAX	-	-	Defined by par. 0104		
1510	MINIMUM AO2	0.0...20.0 mA	0.1 mA	0.0 mA		

Code	Name	Range	Resolution	Default	User	S
1511	MAXIMUM AO2	0.0...20.0 mA	0.1 mA	20.0 mA		
1512	FILTER AO2	0.0...10.0 s	0.1 s	0.1 s		
Group 16: System Controls						
1601	RUN ENABLE	-6...7	1	0		✓
1602	PARAMETER LOCK	0...2	1	1		
1603	PASS CODE	0...65535	1	0		
1604	FAULT RESET SEL	-6...8	1	0		
1605	USER PAR SET CHG	-6...6	1	0		
1606	LOCAL LOCK	-6...8	1	0		
1607	PARAM SAVE	0 = DONE, 1 = SAVE	1	0		
1608	START ENABLE 1	-6...7	1	0		
1609	START ENABLE 2	-6...7	1	0		
1610	DISPLAY ALARMS	0...1	1	0		
Group 17: Override Mode						
1701	OVERRIDE SEL	-6...6	1	0		
1702	OVERRIDE FREQ	0.0...500.0 Hz / +N688:0.0...50.0 Hz / +N689:-0.0...55.0 Hz	0.1Hz	0.0		
1704	OVERRIDE PASSCODE	0...65535	1	0		
1705	OVERRIDE ENABLE	0...2	1	0		
1706	OVERRIDE DIR	-6...7	1	0		
1707	OVERRIDE REF	1...2	1	1		
Group 20: Limits						
2003	MAX CURRENT	0... 1.1 * I _{2n}	0.1 A	1.1 * I _{2n}		✓
2005	OVERVOLT CTRL	0 = DISABLE, 1 = ENABLE	1	1		
2006	UNDERVOLT CTRL	0 = DISABLE, 1 = ENABLE (TIME), 2 = ENABLE	1	1		
2007	MINIMUM FREQ	-500.0...500.0 Hz / +N688:-50.0...50.0 Hz / +N689:-55.0...55.0 Hz	0.1 Hz	0.0 Hz		✓
2008	MAXIMUM FREQ	0...500.0 Hz / +N688:0...50.0 Hz / +N689:0...55.0 Hz	0.1 Hz	50.0 Hz / +N688:50.0 Hz / +N689:55.0 Hz		✓
Group 21: Start/Stop						
2101	START FUNCTION	1...5, 8	1	8		✓
2102	STOP FUNCTION	1 = COAST, 2 = RAMP	1	1		
2103	DC MAGN TIME	0.00...10.00 s	0.01 s	0.30 s		
2104	DC CURR CTL	0, 2	-	0		✓
2106	DC CURR REF	0%...100%	1%	30%		
2107	DC BRAKE TIME	0.0...250.0 s	0.1 s	0.0 s		
2108	START INHIBIT	0 = OFF, 1 = ON	1	0		✓
2109	EM STOP SEL	-6...6	1	0		
2110	TORQ BOOST CURR	15...300%	1%	100%		
2113	START DELAY	0.00...60.00 s	0.01 s	0.00 s		

Code	Name	Range	Resolution	Default	User	S
Group 22: Accel/Decel						
2201	ACC/DEC 1/2 SEL	-6...7	1	5		
2202	ACCELER TIME 1	0.0...1800.0 s	0.1 s	5.0 s		
2203	DECELER TIME 1	0.0...1800.0 s	0.1 s	5.0 s		
2204	RAMP SHAPE 1	0=LINEAR; 0.1...1000.0 s	0.1 s	0.0 s		
2205	ACCELER TIME 2	0.0...1800.0 s	0.1 s	60.0 s		
2206	DECELER TIME 2	0.0...1800.0 s	0.1 s	60.0 s		
2207	RAMP SHAPE 2	0=LINEAR; 0.1...1000.0 s	0.1 s	0.0 s		
2208	EM DEC TIME	0.0...1800.0 s	0.1 s	1.0 s		
2209	RAMP INPUT 0	-6...7	1	0		
Group 25: Critical Speeds						
2501	CRIT SPEED SEL	0 = OFF, 1 = ON	1	0		
2502	CRIT SPEED 1 LO	0.0...500.0 Hz / +N688:0.0...50.0 Hz / +N689:0.0...55.0 Hz	0.1 Hz	0.0 Hz		
2503	CRIT SPEED 1 HI	0.0...500.0 Hz / +N688:0.0...50.0 Hz / +N689:0.0...55.0 Hz	0.1 Hz	0.0 Hz		
2504	CRIT SPEED 2 LO	0.0...500.0 Hz / +N688:0.0...50.0 Hz / +N689:0.0...55.0 Hz	0.1 Hz	0.0 Hz		
2505	CRIT SPEED 2 HI	0.0...500.0 Hz / +N688:0.0...50.0 Hz / +N689:0.0...55.0 Hz	0.1 Hz	0.0 Hz		
2506	CRIT SPEED 3 LO	0.0...500.0 Hz / +N688:0.0...50.0 Hz / +N689:0.0...55.0 Hz	0.1 Hz	0.0 Hz		
2507	CRIT SPEED 3 HI	0.0...500.0 Hz / +N688:0.0...50.0 Hz / +N689:0.0...55.0 Hz	0.1 Hz	0.0 Hz		
Group 26: Motor Control						
2601	FLUX OPT ENABLE	0 = OFF, 1 = ON	1	0		
2602	FLUX BRAKING	0 = OFF, 1 = ON	1	0		
2603	IR COMP VOLT	0.0 ...100.0 V	0.1 V	Size dependent		
2604	IR COMP FREQ	0...100%	1%	80%		
2605	U/F RATIO	1 = LINEAR, 2 = SQUARED, 3 = FREELY DEFINED	1	2		
2606	SWITCHING FREQ	1, 4, 8, 12 kHz	-	4 kHz		
2607	SW FREQ CTRL	0 = OFF, 1 = ON	1	1		
2608	SLIP COMP RATIO	0...200%	1%	0		
2609	NOISE SMOOTHING	0 = DISABLE, 1 = ENABLE	1	0		
2610	USER U1	0...480 V	1 V	76 V		
2611	USER F1	0.0...500.0 Hz / +N688:0.0...50.0 Hz / +N689:0.0...55.0 Hz	0.1 Hz	10.0 Hz / +N688:10.0 Hz / +N689:11.0 Hz		
2612	USER U2	0...480 V	1 V	152 V		

Code	Name	Range	Resolution	Default	User	S
2613	USER F2	0.0...500.0 Hz / +N688:0.0...50.0 Hz / +N689:0.0...55.0 Hz	0.1 Hz	20.0 Hz / +N688:20.0 Hz / +N689:22.0 Hz		
2614	USER U3	0...480 V	1 V	228 V		
2615	USER F3	0.0...500.0 Hz / +N688:0.0...50.0 Hz / +N689:0.0...55.0 Hz	0.1 Hz	30.0 Hz / +N688:30.0 Hz / +N689:33.0 Hz		
2616	USER U4	0...480 V	1 V	304 V		
2617	USER F4	0.0...500.0 Hz / +N688:0.0...50.0 Hz / +N689:0.0...55.0 Hz	0.1 Hz	40.0 Hz / +N688:40.0 Hz / +N689:44.0 Hz		
2618	FW VOLTAGE	190...480 V	1 V	380 V		
2619	DC STABILIZER	0...1	1	0		
Group 30: Fault Functions						
3001	AI<MIN FUNCTION	0...3	1	0		
3002	PANEL COMM ERR	1...3	1	1		
3003	EXTERNAL FAULT 1	-6...6	1	0		
3004	EXTERNAL FAULT 2	-6...6	1	0		
3005	MOT THERM PROT	0 = NOT SEL, 1 = FAULT, 2 = WARNING	1	1 (FAULT)		
3006	MOT THERM TIME	256...9999 s	1	1050 s		
3007	MOT LOAD CURVE	50...150%	1	100%		
3008	ZERO SPEED LOAD	25...150%	1	70%		
3009	BREAK POINT FREQ	1...250 Hz	1	35 Hz		
3010	STALL FUNCTION	0...2	1	0 (NOT SEL)		
3011	STALL FREQUENCY	0.5...50.0 Hz	0.1 Hz	20.0 Hz		
3012	STALL TIME	10...400 s	1 s	20 s		
3017	EARTH FAULT	0 = DISABLE, 1 = ENABLE	1	1 (ENABLE)		
3018	COMM FAULT FUNC	0 = NOT SEL, 1 = FAULT, 2 = CONST SP 7, 3 = LAST SPEED	1	0 (NOT SEL)		
3019	COMM FAULT TIME	0.0...60.0 s	0.1 s	10.0 s		
3021	AI1 FAULT LIMIT	0.0...100.0%	0.1%	0.0%		
3022	AI2 FAULT LIMIT	0.0...100.0%	0.1%	0.0%		
3023	WIRING FAULT	0 = DISABLE, 1 = ENABLE	1	1		
3024	CB TEMP FAULT	0...1	1	1		
Group 31: Automatic Reset						
3101	NUMBER OF TRIALS	0...5	1	5		
3102	TRIAL TIME	1.0...600.0 s	0.1 s	30.0 s		
3103	DELAY TIME	0.0...120.0 s	0.1 s	6.0 s		
3104	AR OVERCURRENT	0 = DISABLE, 1 = ENABLE	1	1		
3105	AR OVERVOLTAGE	0 = DISABLE, 1 = ENABLE	1	1		
3106	AR UNDERVOLTAGE	0 = DISABLE, 1 = ENABLE	1	1		
3107	AR AI<MIN	0 = DISABLE, 1 = ENABLE	1	1		
3108	AR EXTERNAL FLT	0 = DISABLE, 1 = ENABLE	1	1		
Group 32: Supervision						
3201	SUPERV 1 PARAM	100...159	1	103		
3202	SUPERV 1 LIM LO	-	-	0		

Code	Name	Range	Resolution	Default	User	S
3203	SUPERV 1 LIM HI	-	-	0		
3204	SUPERV 2 PARAM	100...159	1	104		
3205	SUPERV 2 LIM LO	-	-	0		
3206	SUPERV 2 LIM HI	-	-	0		
3207	SUPERV 3 PARAM	100...159	1	105		
3208	SUPERV 3 LIM LO	-	-	0		
3209	SUPERV 3 LIM HI	-	-	0		
Group 33: Information						
3301	FIRMWARE	0000...FFFF hex	1	Firmware version		
3302	LOADING PACKAGE	0000...FFFF hex	1	0		
3303	TEST DATE	yy.ww	1	0		
3304	DRIVE RATING	-	-	-		
3305	PARAMETER TABLE	0000...FFFF hex	1	Par. table version		
Group 34: Panel Display / Process Variables						
3401	SIGNAL 1 PARAM	100...159	1	103		
3402	SIGNAL 1 MIN	-	1	-		
3403	SIGNAL 1 MAX	-	1	-		
3404	OUTPUT 1 DSP FORM	0...9	1	9		
3405	OUTPUT 1 UNIT	0...127	1	.		
3406	OUTPUT 1 MIN	-	1	-		
3407	OUTPUT 1 MAX	-	1	-		
3408	SIGNAL 2 PARAM	100...159	1	104		
3409	SIGNAL 2 MIN	-	1	-		
3410	SIGNAL 2 MAX	-	1	-		
3411	OUTPUT 2 DSP FORM	0...9	1	9		
3412	OUTPUT 2 UNIT	0...127	1	-		
3413	OUTPUT 2 MIN	-	1	-		
3414	OUTPUT 2 MAX	-	1	-		
3415	SIGNAL 3 PARAM	100...159	1	105		
3416	SIGNAL 3 MIN	-	1	-		
3417	SIGNAL 3 MAX	-	1	-		
3418	OUTPUT 3 DSP FORM	0...9	1	9		
3419	OUTPUT 3 UNIT	0...127	1	.		
3420	OUTPUT 3 MIN	-	1	-		
3421	OUTPUT 3 MAX	-	1	-		
Group 35: Motor Temp Meas						
3501	SENSOR TYPE	0...6	1	0		
3502	INPUT SELECTION	1...8	1	1		
3503	ALARM LIMIT	-10...200 °C / 0...5000 Ohm / 0...1	1	110 °C / 1500 Ohm / 0		
3504	FAULT LIMIT	-10...200 °C / 0...5000 Ohm / 0...1	1	130 °C / 4000 Ohm / 0		
Group 37: User Adjustable Load Curves						
3701	USER LOAD C MODE	0...3	1	0		
3702	USER LOAD C FUNC	1...2	1	1		
3703	USER LOAD C TIME	10...400 s	1 s	20 s		
3704	LOAD FREQ 1	0...500 Hz	1 Hz	5 Hz		

Code	Name	Range	Resolution	Default	User	S
3705	LOAD TORQ LOW 1	0%...600%	1%	10%		
3706	LOAD TORQ HIGH 1	0%...600%	1%	300%		
3707	LOAD FREQ 2	0...500 Hz	1 Hz	25 Hz		
3708	LOAD TORQ LOW 2	0%...600%	1%	15%		
3709	LOAD TORQ HIGH 2	0%...600%	1%	300%		
3710	LOAD FREQ 3	0...500 Hz	1 Hz	43 Hz		
3711	LOAD TORQ LOW 3	0%...600%	1%	25%		
3712	LOAD TORQ HIGH 3	0%...600%	1%	300%		
3713	LOAD FREQ 4	0...500 Hz	1 Hz	50 Hz		
3714	LOAD TORQ LOW 4	0%...600%	1%	30%		
3715	LOAD TORQ HIGH 4	0%...600%	1%	300%		
3716	LOAD FREQ 5	0...500 Hz	1 Hz	500 Hz		
3717	LOAD TORQ LOW 5	0%...600%	1%	30%		
3718	LOAD TORQ HIGH 5	0%...600%	1%	300%		
Group 40: Process PID Set 1						
4001	GAIN	0.1...100	0.1	2.5		
4002	INTEGRATION TIME	0.0s = NOT SEL, 0.1...3600.0 s	0.1 s	3.0 s		
4003	DERIVATION TIME	0...10.0 s	0.1 s	0.0 s		
4004	PID DERIV FILTER	0...10.0 s	0.1 s	1.0 s		
4005	ERROR VALUE INV	0 = NO, 1 = YES	-	0		
4006	UNITS	0...127	1	4		
4007	UNIT SCALE	0...4	1	1		
4008	0% VALUE	Unit and scale defined by par. 4006 and 4007	-	0.0%		
4009	100% VALUE	Unit and scale defined by par. 4006 and 4007	-	100.0%		
4010	SET POINT SEL	0...2, 8...17, 19, 20	1	1		✓
4011	INTERNAL SETPNT	Unit and scale defined by par. 4006 and 4007	0.1%	40.0%		
4012	SETPOINT MIN	-500.0%...500.0%	0.1%	0.0%		
4013	SETPOINT MAX	-500.0%...500.0%	0.1%	100.0%		
4014	FBK SEL	1...13	1	1		
4015	FBK MULTIPLIER	-32.768...32.767 (0 = not used)	0.001	0		
4016	ACT1 INPUT	1...7	1	2		✓
4017	ACT2 INPUT	1...7	1	2		✓
4018	ACT1 MINIMUM	-1000...1000%	1%	0%		
4019	ACT1 MAXIMUM	-1000...1000%	1%	100%		
4020	ACT2 MINIMUM	-1000...1000%	1%	0%		
4021	ACT2 MAXIMUM	-1000...1000%	1%	100%		
4022	SLEEP SELECTION	-6...7	1	0		
4023	PID SLEEP LEVEL	0.0...500.0 Hz / +N688:0.0...50.0 Hz / +N689:0.0...55.0 Hz	0.1 Hz	0.0 Hz		
4024	PID SLEEP DELAY	0.0...3600.0 s	0.1 s	60.0 s		
4025	WAKE-UP DEV	Unit and scale defined by par. 4006 and 4007	-	0.0%		

Code	Name	Range	Resolution	Default	User	S
4026	WAKE-UP DELAY	0...60 s	0.01 s	0.50 s		
4027	PID 1 PARAM SET	-6...7	1	0		
Group 41: Process PID Set 2						
4101	GAIN	0.1...100	0.1	2.5		
4102	INTEGRATION TIME	0.0s = NOT SEL, 0.1...3600 s	0.1 s	3.0 s		
4103	DERIVATION TIME	0.0...10.0 s	0.1 s	0.0 s		
4104	PID DERIV FILTER	0.0...10.0 s	0.1 s	1.0 s		
4105	ERROR VALUE INV	0 = NO, 1 = YES	-	0		
4106	UNITS	0...127	1	4		
4107	UNIT SCALE	0...4	1	1		
4108	0% VALUE	Unit and scale defined by par. 4106 and 4107	-	0.0%		
4109	100% VALUE	Unit and scale defined by par. 4106 and 4107	-	100.0%		
4110	SET POINT SEL	0...2, 8...17, 19, 20	1	1		✓
4111	INTERNAL SETPNT	Unit and scale defined by par. 4106 and 4107	0.1%	40.0%		
4112	SETPOINT MIN	-500.0%...500.0%	0.1%	0.0%		
4113	SETPOINT MAX	-500.0%...500.0%	0.1%	100.0%		
4114	FBK SEL	1...13	1	1		
4115	FBK MULTIPLIER	-32.768...32.767 (0 = NOT USED)	0.001	0		
4116	ACT1 INPUT	1...7	1	2		✓
4117	ACT2 INPUT	1...7	1	2		✓
4118	ACT1 MINIMUM	-1000...1000%	1%	0%		
4119	ACT1 MAXIMUM	-1000...1000%	1%	100%		
4120	ACT2 MINIMUM	-1000...1000%	1%	0%		
4121	ACT2 MAXIMUM	-1000...1000%	1%	100%		
4122	SLEEP SELECTION	-6...7	1	0		
4123	PID SLEEP LEVEL	0.0...500.0 Hz / +N688:0.0...50.0 Hz / +N689:0.0...55.0 Hz	0.1 Hz	0.0 Hz		
4124	PID SLEEP DELAY	0.0...3600.0 s	0.1 s	60.0 s		
4125	WAKE-UP DEV	Unit and scale defined by par. 4106 and 4107	-	0.0%		
4126	WAKE-UP DELAY	0.00...60.00 s	0.01 s	0.50 s		
Group 42: Ext / Trim PID						
4201	GAIN	0.1...100.0	0.1	1.0		
4202	INTEGRATION TIME	0.0s = NOT SEL, 0.1...3600.0 s	0.1 s	60.0 s		
4203	DERIVATION TIME	0.0...10.0 s	0.1 s	0.0 s		
4204	PID DERIV FILTER	0.0...10.0 s	0.1 s	1.0 s		
4205	ERROR VALUE INV	0 = NO, 1 = YES	1	0		
4206	UNITS	0...127	1	4		
4207	UNIT SCALE	0...4	1	1		
4208	0% VALUE	Unit and scale defined by par. 4206 and 4207	-	0%		
4209	100% VALUE	Unit and scale defined by par. 4206 and 4207	-	100%		

Code	Name	Range	Resolution	Default	User	S
4210	SET POINT SEL	0...2, 8...17, 19, 20	1	1		✓
4211	INTERNAL SETPNT	Unit and scale defined by par. 4206 and 4207	0.0%	40.0%		
4212	SETPOINT MIN	-500.0%...500.0%	0.1%	0.0%		
4213	SETPOINT MAX	-500.0%...500.0%	0.1%	100.0%		
4214	FBK SEL	1...13	1	1		
4215	FBK MULTIPLIER	-32.768...32.767 (0 = NOT USED)	0.001	0.000		
4216	ACT1 INPUT	1...7	1	2		✓
4217	ACT2 INPUT	1...7	1	2		✓
4218	ACT1 MINIMUM	-1000...1000%	1%	0%		
4219	ACT1 MAXIMUM	-1000...1000%	1%	100%		
4220	ACT2 MINIMUM	-1000...1000%	1%	0%		
4221	ACT2 MAXIMUM	-1000...1000%	1%	100%		
4228	ACTIVATE	-6...8	1	0		
4229	OFFSET	0.0...100.0%	0.1%	0.0%		
4230	TRIM MODE	0...3	1	0		
4231	TRIM SCALE	-100.0%...100.0%	0.1%	0.0%		
4232	CORRECTION SRC	1...2	1	1 (PID2 REF)		
Group 51: Ext Comm Module						
5101	FBA TYPE	-	-	0		
5102... 5126	FB PAR 2...26	0...65535	1	0		
5127	FBA PAR REFRESH	0 = done, 1 = refresh	1	0		✓
5128	FILE CPI FW REV	0...0xFFFF (hex)	1	0		
5129	FILE CONFIG ID	0...0xFFFF (hex)	1	0		
5130	FILE CONFIG REV	0...0xFFFF (hex)	1	0		
5131	FBA STATUS	0...6	1	0		
5132	FBA CPI FW REV	0...0xFFFF (hex)	1	0		
5133	FBA APPL FW REV	0...0xFFFF (hex)	1	0		
Group 53: EFB Protocol						
5301	EFB PROTOCOL ID	0...0xFFFF	1	0		
5302	EFB STATION ID	0...65535	1	1		✓
5303	EFB BAUD RATE	1.2, 2.4, 4.8, 9.6, 19.2, 38.4, 57.6, 76.8 kbits/s	-	9.6 kbits/s		
5304	EFB PARITY	0 = 8 NONE 1, 1 = 8 NONE2, 2 = 8 EVEN 1, 3 = 8 ODD 1		0		
5305	EFB CTRL PROFILE	0 = ABB DRV LIM, 1 = DCU PROFILE, 2 = ABB DRV FULL	1	0 (ABB DRV LIM)		
5306	EFB OK MESSAGES	0...65535	1	0		
5307	EFB CRC ERRORS	0...65535	1	0		
5308	EFB UART ERRORS	0...65535	1	0		
5309	EFB STATUS	0...7	1	0 (IDLE)		
5310	EFB PAR 10	0...65535	1	0 (NOT SEL)		
5311	EFB PAR 11	0...65535	1	0 (NOT SEL)		
5312	EFB PAR 12	0...65535	1	0 (NOT SEL)		
5313	EFB PAR 13	0...65535	1	0 (NOT SEL)		

Code	Name	Range	Resolution	Default	User	S
5314	EFB PAR 14	0...65535	1	0 (NOT SEL)		
5315	EFB PAR 15	0...65535	1	0 (NOT SEL)		
5316	EFB PAR 16	0...65535	1	0 (NOT SEL)		
5317	EFB PAR 17	0...65535	1	0 (NOT SEL)		
5318	EFB PAR 18	0...65535	1	0		
5319	EFB PAR 19	0...0xFFFF (hex)	1	0		
5320	EFB PAR 20	0...0xFFFF (hex)	1	0		
Group 81: PFC Control						
8103	REFERENCE STEP 1	0.0...100.0%	0.1%	0.0%		
8104	REFERENCE STEP 2	0.0...100.0%	0.1%	0.0%		
8105	REFERENCE STEP 3	0.0...1000.0%	0.1%	0.0%		
8109	START FREQ 1	0.0...500.0 Hz / +N688:0.0...50.0 Hz / +N689:0.0...55.0 Hz	0.1 Hz	50.0 Hz / +N688:48.0 Hz / +N689:53.0 Hz		
8110	START FREQ 2	0.0...500.0 Hz / +N688:0.0...50.0 Hz / +N689:0.0...55.0 Hz	0.1 Hz	50.0 Hz / +N688:48.0 Hz / +N689:53.0 Hz		
8111	START FREQ 3	0.0...500.0 Hz / +N688:0.0...50.0 Hz / +N689:0.0...55.0 Hz	0.1 Hz	50.0 Hz / +N688:48.0 Hz / +N689:53.0 Hz		
8112	LOW FREQ 1	0.0...500.0 Hz / +N688:0.0...50.0 Hz / +N689:0.0...55.0 Hz	0.1 Hz	25.0 Hz / +N688:25.0 Hz / +N689:27.5Hz		
8113	LOW FREQ 2	0.0...500.0 Hz / +N688:0.0...50.0 Hz / +N689:0.0...55.0 Hz	0.1 Hz	25.0 Hz / +N688:25.0 Hz / +N689:27.5Hz		
8114	LOW FREQ 3	0.0...500.0 Hz / +N688:0.0...50.0 Hz / +N689:0.0...55.0 Hz	0.1 Hz	25.0 Hz / +N688:25.0 Hz / +N689:27.5Hz		
8115	AUX MOT START D	0.0...3600.0 s	0.1 s	5.0 s		
8116	AUX MOT STOP D	0.0...3600.0 s	0.1 s	3.0 s		
8117	NR OF AUX MOT	0...6	1	1		✓
8118	AUTOCHNG INTERV	-0.1...336.0 h	0.1 h	0.0 h (NOT SEL)		✓
8119	AUTOCHNG LEVEL	0.0...100.0%	0.1%	50.0%		
8120	INTERLOCKS	0...6	1	4		✓
8121	REG BYPASS CTRL	0...1	1	0 (NO)		
8122	PFC START DELAY	0.00...10.00 s	0.01 s	0.50 s		
8123	PFC ENABLE	0...2	1	0 (NOT SEL)		✓
8124	ACC IN AUX STOP	0.0...1800.0 s	0.1 s	0.0 s (NOT SEL)		
8125	DEC IN AUX START	0.0...1800.0 s	0.1 s	0.0 s (NOT SEL)		
8127	MOTORS	1...7	1	2		
8128	AUX START ORDER	1...2	1	1		
Group 98: Options						
9802	COMM PROT SEL	0...4	1	0 (NOT SEL)		✓

NOTE: This parameter 1003 is not available in software option +N688 and +N689.

Complete Parameter Descriptions

This section describes the actual signals and parameters for ACS510.

Some values vary depending on the drive software options. This is indicated by "+N688:" or "+N689" in the table below. Refer to the type code on the drive nameplate. For example ACS510-01...+N688

Term	Definition
Actual signal	Signal measured or calculated by the drive. Can be monitored by the user. No user setting possible.
FbEq	Fieldbus equivalent: The scaling between the value shown on the panel and the integer used in serial communication.
Parameter	A user-adjustable operation instruction of the drive.

Group 99: Start-up Data

This group defines special Start-up data required to:

- Set up the drive.
- Enter motor information.

Code	Description
9901	<p>LANGUAGE Selects the display language.</p> <p>0 = ENGLISH 1 = CHINESE 2 = KOREAN 3 = JAPANESE</p>
9902	<p>APPLIC MACRO Selects an application macro. Application macros automatically edit parameters to configure the ACS510 for a particular application.</p> <p>1 = ABB STANDARD 2 = 3-WIRE 3 = ALTERNATE 4 = MOTOR POT 5 = HAND/AUTO 6 = PID CONTROL 7 = PFC CONTROL 15 = SPFC CONTROL 0 = USER S1 LOAD -1 = USER S1 SAVE -2 = USER S2 LOAD -3 = USER S2 SAVE</p>
9905	<p>MOTOR NOM VOLT Defines the nominal motor voltage.</p> <ul style="list-style-type: none"> • Must equal the value on the motor rating plate. • The ACS510 cannot supply the motor with a voltage greater than the mains voltage.
9906	<p>MOTOR NOM CURR Defines the nominal motor current.</p> <ul style="list-style-type: none"> • Must equal the value on the motor rating plate. • Range allowed: $(0.2...2.0) \cdot I_{2n}$.
9907	<p>MOTOR NOM FREQ Defines the nominal motor frequency.</p> <ul style="list-style-type: none"> • Range: 10...500 Hz, or 10...50 HZ (+N688), or 10...55 HZ (+N689). • Sets the frequency at which output voltage equals the MOTOR NOM VOLT. • Field weakening point = Nom Freq * Supply Volt / Mot Nom Volt
9908	<p>MOTOR NOM SPEED Defines the nominal motor speed. Must equal the value on the motor rating plate.</p>

9909	MOTOR NOM POWER Defines the nominal motor power. Must equal the value on the motor rating plate.
------	---

Group 01: Operating Data

This group contains drive operating data, including actual signals. The drive sets the values for actual signals, based on measurements or calculations. You cannot set these values.

Code	Description
0101	SPEED & DIR The calculated signed speed of the motor (rpm). The absolute value of this parameter is the same as the value of 0102 SPEED. <ul style="list-style-type: none"> • The value is positive if the motor runs in the forward direction. • The value is negative if the motor runs in the reverse direction.
0102	SPEED The calculated speed of the motor (rpm).
0103	OUTPUT FREQ The frequency (Hz) applied to the motor. (Shown by default in the control panel OUTPUT mode.)
0104	CURRENT The motor current, as measured by the ACS510. (Shown by default in the control panel OUTPUT mode.)
0105	TORQUE Output torque. Calculated value of torque on motor shaft in % of motor nominal torque. (Shown by default in the control panel OUTPUT mode.)
0106	POWER The measured motor power in kW.
0107	DC BUS VOLTAGE The DC bus voltage in V DC, as measured by the ACS510.
0109	OUTPUT VOLTAGE The voltage applied to the motor.
0110	DRIVE TEMP The temperature of the drive power transistors in degree Celsius.
0111	EXTERNAL REF 1 External reference, REF1, in Hz.
0112	EXTERNAL REF 2 External reference, REF2, in %.
0113	CTRL LOCATION Active control location. Alternatives are: 0 = LOCAL 1 = EXT1 2 = EXT2
0114	RUN TIME (R) The drive's accumulated running time in hours (h). Can be reset by pressing UP and DOWN keys simultaneously when the control panel is in the Parameters mode.
0115	KWH COUNTER (R) The drive's accumulated power consumption in kilowatt hours. Can be reset by pressing UP and DOWN keys simultaneously when the control panel is in the Parameters mode.
0116	APPL BLK OUTPUT Application block output signal. Value is from either: <ul style="list-style-type: none"> • PFC control, if PFC Control is active, or • Parameter 0112 EXTERNAL REF 2.

Code	Description	
0118	DI 1-3 STATUS Status of the three digital inputs. <ul style="list-style-type: none"> • Status is displayed as a binary number. • 1 indicates that the input is activated. • 0 indicates that the input is deactivated. 	
0119	DI 4-6 STATUS Status of the three digital inputs. See parameter 0118 DI 1-3 STATUS.	
0120	AI 1 Relative value of analog input 1 in %.	
0121	AI 2 The relative value of analog input 2 in %.	
0122	RO 1-3 STATUS Status of the three relay outputs. <ul style="list-style-type: none"> • 1 indicates that the relay is energized. • 0 indicates that the relay is de-energized. 	
0123	RO 4-6 STATUS Status of the three relay outputs. See parameter 0122.	
0124	AO 1 The analog output 1 value in milliamperes.	
0125	AO 2 The analog output 2 value in milliamperes.	
0126	PID 1 OUTPUT The PID Controller 1 output value in %.	
0127	PID 2 OUTPUT The PID Controller 2 output value in %.	
0128	PID 1 SETPNT The PID 1 controller setpoint signal. Units and scale defined by PID parameters.	
0129	PID 2 SETPNT The PID 2 controller setpoint signal. Units and scale defined by PID parameters.	
0130	PID 1 FBK The PID 1 controller feedback signal. Units and scale defined by PID parameters.	
0131	PID 2 FBK The PID 2 controller feedback signal. Units and scale defined by PID parameters.	
0132	PID 1 DEVIATION The difference between the PID 1 controller reference value and actual value. Units and scale defined by PID parameters.	
0133	PID 2 DEVIATION The difference between the PID 2 controller reference value and actual value. Units and scale defined by PID parameters.	
0134	COMM RO WORD Free data location that can be written from serial link. <ul style="list-style-type: none"> • Used for relay output control. • See parameter 1401. 	

Code	Description
0135	COMM VALUE 1 Free data location that can be written from serial link.
0136	COMM VALUE 2 Free data location that can be written from serial link.
0137	PROCESS VAR 1 Process variable 1 Defined by parameters in Group 34: Panel Display.
0138	PROCESS VAR 2 Process variable 2 Defined by parameters in Group 34: Panel Display.
0139	PROCESS VAR 3 Process variable 3 Defined by parameters in Group 34: Panel Display.
0140	RUN TIME The drive's accumulated running time in thousands of hours (kh). Cannot be reset.
0141	MWH COUNTER The drive's accumulated power consumption in megawatt hours. Can not be reset.
0142	REVOLUTION CNTR The motor's accumulated revolutions in millions of revolutions. Can be reset by pressing UP and DOWN keys simultaneously when the control panel is in the Parameters mode.
0143	DRIVE ON TIME HI The drive's accumulated power-on time in days. Cannot be reset.
0144	DRIVE ON TIME LO The drive's accumulated power on time in 2 second ticks (30 ticks = 60 seconds). Cannot be reset.
0145	MOTOR TEMP Motor temperature in degrees Celsius / PTC resistance in ohms. Applies only if motor temperature sensor is set up. See parameter 3501.
0146	NOT USED
...	
0148	
0149	OVERRIDE ACTIVED Override mode actived recorder. 1 = Drive is in override mode. Parameter setting or drive control is not possible. Please see parameter group 17. 0 = Drive is in normal operating mode (in override mode). Note! If override mode actived, this ACS510 module is out of warranty.
0150	CB TEMP Temperature of the drive control board in degrees Celsius/Fahrenheit. Note: Some drives have a control board (OMIO) that does not support this feature. These drives always show the constant value of 25.0 °C.
0151	INPUT KWH (R) Calculated actual intake energy in kWh. Can be reset by pressing UP and DOWN keys simultaneously when the control panel is in the Parameters mode.
0152	INPUT MWH Calculated actual intake energy in MWh.
0158	PID COMM VALUE 1 Data received from fieldbus for PID control (PID1 and PID2).
0159	PID COMM VALUE 2 Data received from fieldbus for PID control (PID1 and PID2).

Group 03: FB Actual Signals

This group monitors fieldbus communications.

Code	Description			
0301	FB CMD WORD 1 Read-only copy of the Fieldbus Command Word 1. <ul style="list-style-type: none"> The fieldbus command is the principal means for controlling the drive from a fieldbus controller. The command consists of two Command Words. Bit-coded instructions in the Command Words switch the drive between states. To control the drive, using the Command Words, an external location (EXT1 or EXT2) must be active and set to COMM. (See parameters 1001 and 1002.) The control panel displays the word in hex. For example, all zeros and a 1 in Bit 0 displays as 0001. All zeros and a 1 in Bit 15 displays as 8000. 	Bit #	0301, FB CMD WORD 1	0302, FB CMD WORD 2
		0	STOP	FBLOCAL_CTL
		1	START	FBLOCAL_REF
		2	REVERSE	START_DISABLE 1
		3	LOCAL	START_DISABLE 2
		4	RESET	Reserved
		5	EXT2	Reserved
		6	RUN_DISABLE	Reserved
		7	STPMODE_R	Reserved
		8	STPMODE_EM	Reserved
		9	STPMODE_C	Reserved
		10	RAMP_2	Reserved
		11	RAMP_OUT_0	REF_CONST
		12	RAMP_HOLD	REF_AVE
		13	RAMP_IN_0	LINK_ON
		14	RREQ_LOCALLOC	REQ_STARTINH
15	Reserved	OFF_INTERLOCK		
0302	FB CMD WORD 2 Read-only copy of the Fieldbus Command Word 2. See parameter 0301.			
0303	FB STS WORD 1 Read-only copy of the Status Word 1. <ul style="list-style-type: none"> The drive sends status information to the fieldbus controller. The status consists of two Status Words. The control panel displays the word in hex. For example, all zeros and a 1 in Bit 0 displays as 0001. All zeros and a 1 in Bit 15 displays as 8000. 	Bit #	0303, FB STS WORD 1	0304, FB STS WORD 2
		0	READY	ALARM
		1	ENABLED	NOTICE
		2	STARTED	DIRLOCK
		3	RUNNING	LOCALLOCK
		4	ZERO_SPEED	CTL_MODE
		5	ACCELERATE	Reserved
		6	DECELERATE	Reserved
		7	AT_SETPOINT	CPY_CTL
		8	LIMIT	CPY_REF 1
		9	SUPERVISION	CPY_REF 2
		10	REV_REF	REQ_CTL
		11	REV_ACT	REQ_REF1
		12	PANEL_LOCAL	REQ_REF2
		13	FIELDBUS_LOCAL	REQ_REF2EXT
		14	EXT2_ACT	ACK_STARTINH
15	FAULT	ACK_OFF_ILCK		
0304	FB STS WORD 2 Read-only copy of the Status Word 2. See parameter 0303.			

0305	FAULT WORD 1 Read-only copy of the Fault Word 1. <ul style="list-style-type: none"> When a fault is active, the corresponding bit for the active fault is set in the Fault Words. Each fault has a dedicated bit allocated within Fault Words. See "Fault Listing" on page 197 for a description of the faults. The control panel displays the word in hex. For example, all zeros and a 1 in Bit 0 displays as 0001. All zeros and a 1 in Bit 15 displays as 8000. 	<table border="1"> <thead> <tr> <th>Bit #</th> <th>0305, FAULT WORD 1</th> <th>0306, FAULT WORD 2</th> <th>0307, FAULT WORD 3</th> </tr> </thead> <tbody> <tr><td>0</td><td>OVERCURRENT</td><td>Obsolete</td><td>EFB 1</td></tr> <tr><td>1</td><td>DC OVERVOLT</td><td>THERM FAIL</td><td>EFB 2</td></tr> <tr><td>2</td><td>DEV OVERTEMP</td><td>OPEX LINK</td><td>EFB 3</td></tr> <tr><td>3</td><td>SHORT CIRC</td><td>OPEX PWR</td><td>INCOMPATIBLE SW</td></tr> <tr><td>4</td><td>Reserved</td><td>CURR MEAS</td><td>USER LOAD CURVE</td></tr> <tr><td>5</td><td>DC UNDERVOLT</td><td>SUPPLY PHASE</td><td>Reserved</td></tr> <tr><td>6</td><td>AI1 LOSS</td><td>Reserved</td><td>Reserved</td></tr> <tr><td>7</td><td>AI2 LOSS</td><td>Reserved</td><td>Reserved</td></tr> <tr><td>8</td><td>MOT OVERTEMP</td><td>Reserved</td><td>Reserved</td></tr> <tr><td>9</td><td>PANEL LOSS</td><td>DRIVE ID</td><td>Reserved</td></tr> <tr><td>10</td><td>Reserved</td><td>CONFIG FILE</td><td>System error</td></tr> <tr><td>11</td><td>MOTOR STALL</td><td>SERIAL 1 ERR</td><td>System error</td></tr> <tr><td>12</td><td>CB OVERTEMP</td><td>EFB CON FILE</td><td>System error</td></tr> <tr><td>13</td><td>EXT FAULT 1</td><td>FORCE TRIP</td><td>System error</td></tr> <tr><td>14</td><td>EXT FAULT 2</td><td>MOTOR PHASE</td><td>System error</td></tr> <tr><td>15</td><td>EARTH FAULT</td><td>OUTP WIRING</td><td>Param. setting fault</td></tr> </tbody> </table>			Bit #	0305, FAULT WORD 1	0306, FAULT WORD 2	0307, FAULT WORD 3	0	OVERCURRENT	Obsolete	EFB 1	1	DC OVERVOLT	THERM FAIL	EFB 2	2	DEV OVERTEMP	OPEX LINK	EFB 3	3	SHORT CIRC	OPEX PWR	INCOMPATIBLE SW	4	Reserved	CURR MEAS	USER LOAD CURVE	5	DC UNDERVOLT	SUPPLY PHASE	Reserved	6	AI1 LOSS	Reserved	Reserved	7	AI2 LOSS	Reserved	Reserved	8	MOT OVERTEMP	Reserved	Reserved	9	PANEL LOSS	DRIVE ID	Reserved	10	Reserved	CONFIG FILE	System error	11	MOTOR STALL	SERIAL 1 ERR	System error	12	CB OVERTEMP	EFB CON FILE	System error	13	EXT FAULT 1	FORCE TRIP	System error	14	EXT FAULT 2	MOTOR PHASE	System error	15	EARTH FAULT	OUTP WIRING	Param. setting fault
Bit #	0305, FAULT WORD 1	0306, FAULT WORD 2	0307, FAULT WORD 3																																																																					
0	OVERCURRENT	Obsolete	EFB 1																																																																					
1	DC OVERVOLT	THERM FAIL	EFB 2																																																																					
2	DEV OVERTEMP	OPEX LINK	EFB 3																																																																					
3	SHORT CIRC	OPEX PWR	INCOMPATIBLE SW																																																																					
4	Reserved	CURR MEAS	USER LOAD CURVE																																																																					
5	DC UNDERVOLT	SUPPLY PHASE	Reserved																																																																					
6	AI1 LOSS	Reserved	Reserved																																																																					
7	AI2 LOSS	Reserved	Reserved																																																																					
8	MOT OVERTEMP	Reserved	Reserved																																																																					
9	PANEL LOSS	DRIVE ID	Reserved																																																																					
10	Reserved	CONFIG FILE	System error																																																																					
11	MOTOR STALL	SERIAL 1 ERR	System error																																																																					
12	CB OVERTEMP	EFB CON FILE	System error																																																																					
13	EXT FAULT 1	FORCE TRIP	System error																																																																					
14	EXT FAULT 2	MOTOR PHASE	System error																																																																					
15	EARTH FAULT	OUTP WIRING	Param. setting fault																																																																					
0306	FAULT WORD 2 Read-only copy of the Fault Word 2. See parameter 0305.																																																																							
0307	FAULT WORD 3 Read-only copy of the Fault Word 3. See parameter 0305.																																																																							
0308	ALARM WORD 1 <ul style="list-style-type: none"> When an alarm is active, the corresponding bit for the active alarm is set in the Alarm Words. Each alarm has a dedicated bit allocated within Alarm Words. Bits remain set until the whole alarm word is reset. (Reset by writing zero to the word.) The control panel displays the word in hex. For example, all zeros and a 1 in Bit 0 displays as 0001. All zeros and a 1 in Bit 15 displays as 8000. 	<table border="1"> <thead> <tr> <th>Bit #</th> <th>0308, ALARM WORD 1</th> <th>0309, ALARM WORD 2</th> </tr> </thead> <tbody> <tr><td>0</td><td>OVERCURRENT</td><td>OFF BUTTON</td></tr> <tr><td>1</td><td>OVERVOLTAGE</td><td>PID SLEEP</td></tr> <tr><td>2</td><td>UNDERVOLTAGE</td><td>Reserved</td></tr> <tr><td>3</td><td>DIRLOCK</td><td>Reserved</td></tr> <tr><td>4</td><td>COMM LOSS</td><td>START ENABLE 1</td></tr> <tr><td>5</td><td>AI1 LOSS</td><td>START ENABLE 2</td></tr> <tr><td>6</td><td>AI2 LOSS</td><td>EMERGENCY STOP</td></tr> <tr><td>7</td><td>PANEL LOSS</td><td>Reserved</td></tr> <tr><td>8</td><td>DEVICE OVERTEMP</td><td>Reserved</td></tr> <tr><td>9</td><td>MOTOR TEMP</td><td>Reserved</td></tr> <tr><td>10</td><td>Reserved</td><td>USER LOAD CURVE</td></tr> <tr><td>11</td><td>MOTOR STALL</td><td>START DELAY</td></tr> <tr><td>12</td><td>AUTORESET</td><td>Reserved</td></tr> <tr><td>13</td><td>PFC AUTOCHANGE</td><td>Reserved</td></tr> <tr><td>14</td><td>PFC ILOCK</td><td>Reserved</td></tr> <tr><td>15</td><td>Reserved</td><td>Reserved</td></tr> </tbody> </table>			Bit #	0308, ALARM WORD 1	0309, ALARM WORD 2	0	OVERCURRENT	OFF BUTTON	1	OVERVOLTAGE	PID SLEEP	2	UNDERVOLTAGE	Reserved	3	DIRLOCK	Reserved	4	COMM LOSS	START ENABLE 1	5	AI1 LOSS	START ENABLE 2	6	AI2 LOSS	EMERGENCY STOP	7	PANEL LOSS	Reserved	8	DEVICE OVERTEMP	Reserved	9	MOTOR TEMP	Reserved	10	Reserved	USER LOAD CURVE	11	MOTOR STALL	START DELAY	12	AUTORESET	Reserved	13	PFC AUTOCHANGE	Reserved	14	PFC ILOCK	Reserved	15	Reserved	Reserved																	
Bit #	0308, ALARM WORD 1	0309, ALARM WORD 2																																																																						
0	OVERCURRENT	OFF BUTTON																																																																						
1	OVERVOLTAGE	PID SLEEP																																																																						
2	UNDERVOLTAGE	Reserved																																																																						
3	DIRLOCK	Reserved																																																																						
4	COMM LOSS	START ENABLE 1																																																																						
5	AI1 LOSS	START ENABLE 2																																																																						
6	AI2 LOSS	EMERGENCY STOP																																																																						
7	PANEL LOSS	Reserved																																																																						
8	DEVICE OVERTEMP	Reserved																																																																						
9	MOTOR TEMP	Reserved																																																																						
10	Reserved	USER LOAD CURVE																																																																						
11	MOTOR STALL	START DELAY																																																																						
12	AUTORESET	Reserved																																																																						
13	PFC AUTOCHANGE	Reserved																																																																						
14	PFC ILOCK	Reserved																																																																						
15	Reserved	Reserved																																																																						
0309	ALARM WORD 2 See parameter 0308.																																																																							

Group 04: Fault History

This group stores a recent history of the faults reported by the drive.

Code	Description
0401	LAST FAULT 0 - Clear the fault history (on panel = NO RECORD). n - Fault code of the last recorded fault.
0402	FAULT TIME 1 The day on which the last fault occurred. The number of days after power on .
0403	FAULT TIME 2 The time at which the last fault occurred... The time since power on (minus the whole days reported in 0402), in format hh:mm:ss.
0404	SPEED AT FLT The motor speed (rpm) at the time the last fault occurred.
0405	FREQ AT FLT The frequency (Hz) at the time the last fault occurred.
0406	VOLTAGE AT FLT The DC bus voltage (V) at the time the last fault occurred.
0407	CURRENT AT FLT The motor current (A) at the time the last fault occurred.
0408	TORQUE AT FLT The motor torque (%) at the time the last fault occurred.
0409	STATUS AT FLT The drive status (hex code word) at the time the last fault occurred.
0410	DI 1-3 AT FLT The status of digital inputs 1...3 at the time the last fault occurred.
0411	DI 4-6 AT FLT The status of digital inputs 4...6 at the time the last fault occurred.
0412	PREVIOUS FAULT 1 Fault code of the second last fault. Read-only.
0413	PREVIOUS FAULT 2 Fault code of the third last fault. Read-only.

Group 10: Start/Stop/Dir

This group:

- Defines external sources (EXT1, and EXT2) for commands that enable start, stop and direction changes.
- Locks direction or enables direction control.

To select between the two external locations use the next group (parameter 1102).

Code	Description
1001	<p>EXT1 COMMANDS</p> <p>Defines external control location 1 (EXT1) – the configuration of start, stop and direction commands.</p> <p>0 = NOT SEL – No external start, stop and direction command source.</p> <p>1 = DI1 – Two-wire Start/Stop.</p> <ul style="list-style-type: none"> • Start/Stop is through digital input DI1 (DI1 activated = Start; DI1 de-activated = Stop). • Parameter 1003 defines the direction. Selecting 1003 = 3 (REQUEST) is the same as 1003 = 1 (FWD). <p>2 = DI1,2 – Two-wire Start/Stop, Direction.</p> <ul style="list-style-type: none"> • Start/Stop is through digital input DI1 (DI1 activated = Start; DI1 de-activated = Stop). • Direction control (requires parameter 1003 = 3 (REQUEST)) is through digital input DI2 (DI2 activated = Reverse; de-activated = Forward). <p>3 = DI1P,2P – Three-wire Start/Stop.</p> <ul style="list-style-type: none"> • Start/Stop commands are through momentary push-buttons (the P stands for “pulse”). • Start is through a normally open push-button connected to digital input DI1. In order to start the drive, the digital input DI2 must be activated prior to the pulse in DI1. • Connect multiple Start push-buttons in parallel. • Stop is through a normally closed push-button connected to digital input DI2. • Connect multiple Stop push-buttons in series. • Parameter 1003 defines the direction. Selecting 1003 = 3 (REQUEST) is the same as 1003 = 1 (FWD). <p>4 = DI1P, 2P, 3 – Three-wire Start/Stop, Direction.</p> <ul style="list-style-type: none"> • Start/Stop commands are through momentary push-buttons, as described for DI1P, 2P. • Direction control (requires parameter 1003 = 3 (REQUEST)) is through digital input DI3 (DI3 activated = Reverse; de-activated = Forward). <p>5 = DI1P, 2P, 3P – Start Forward, Start Reverse, and Stop.</p> <ul style="list-style-type: none"> • Start and Direction commands are given simultaneously with two separate momentary push-buttons (the P stands for “pulse”). • Start Forward command is through a normally open push-button connected to digital input DI1. In order to start the drive, the digital input DI3 must be activated prior to the pulse in DI1. • Start Reverse command is through a normally open push-button connected to digital input DI2. In order to start the drive, the digital input DI3 must be activated during the pulse in DI2. • Connect multiple Start push-buttons in parallel. • Stop is through a normally closed push-button connected to digital input DI3. • Connect multiple Stop push-buttons in series. • Requires parameter 1003 = 3 (REQUEST). <p>6 = DI6 – Two-wire Start/Stop.</p> <ul style="list-style-type: none"> • Start/Stop is through digital input DI6 (DI6 activated = Start; DI6 de-activated = Stop). • Parameter 1003 defines the direction. Selecting 1003 = 3 (REQUEST) is the same as 1003 = 1 (FWD). <p>7 = DI6, 5 – Two-wire Start/Stop/Direction.</p> <ul style="list-style-type: none"> • Start/Stop is through digital input DI6 (DI6 activated = Start; DI6 de-activated = Stop). • Direction control (requires parameter 1003 = 3 (REQUEST)) is through digital input DI5 (DI5 activated = Reverse; de-activated = Forward). <p>8 = KEYPAD – Control Panel.</p> <ul style="list-style-type: none"> • Start/Stop and Direction commands are through the control panel when EXT1 is active. • Direction control requires parameter 1003 = 3 (REQUEST). <p>9 = DI1F, 2R – Start/Stop/Direction commands through DI1 and DI2 combinations.</p> <ul style="list-style-type: none"> • Start forward = DI1 activated and DI2 de-activated. • Start reverse = DI1 de-activated and DI2 activated. • Stop = both DI1 and DI2 activated, or both de-activated. • Requires parameter 1003 = 3 (REQUEST). <p>10 = COMM – Assigns the fieldbus Command Word as the source for the start/stop and direction commands.</p> <ul style="list-style-type: none"> • Bits 0,1, 2 of Command Word 1 (parameter 0301) activates the start/stop and direction commands. • See Fieldbus user's manual for detailed instructions.

Code	Description
1002	EXT2 COMMANDS Defines external control location 2 (EXT2) – the configuration of start, stop and direction commands. See parameter 1001 EXT1 COMMANDS above.
1003	DIRECTION Defines the control of motor rotation direction. 1 = FORWARD – Rotation is fixed in the forward direction. 2 = REVERSE – Rotation is fixed in the reverse direction. 3 = REQUEST – Rotation direction can be changed on command. Note! This parameter is not available in software option +N688 and +N689.

Group 11: Reference Select

This group defines:

- How the drive selects between command sources.
- Characteristics and sources for REF1 and REF2.

Code	Description
1101	<p>KEYPAD REF SEL</p> <p>Selects the reference controlled in local control mode.</p> <p>1 = REF1 (Hz) – Frequency reference as hertz.</p> <p>2 = REF2 (%) – Reference as percentage.</p>
1102	<p>EXT1/EXT2 SEL</p> <p>Defines the source for selecting between the two external control locations EXT1 or EXT2. Thus, defines the source for Start/Stop/Direction commands and reference signals.</p> <p>0 = EXT1 – Selects external control location 1 (EXT1).</p> <ul style="list-style-type: none"> • See parameter 1001 EXT1 COMMANDS for EXT1's Start/Stop/Dir definitions. • See parameter 1103 REF1 SELECT for EXT1's reference definitions. <p>1 = DI1 – Assigns control to EXT1 or EXT2 based on the state of DI1 (DI1 activated = EXT2; DI1 de-activated = EXT1).</p> <p>2...6 = DI2...DI6 – Assigns control to EXT1 or EXT2 based on the state of the selected digital input. See DI1 above.</p> <p>7 = EXT2 – Selects external control location 2 (EXT2).</p> <ul style="list-style-type: none"> • See parameter 1002 EXT2 COMMANDS for EXT2's Start/Stop/Dir definitions. • See parameter 1106 REF2 SELECT for EXT2's reference definitions. <p>8 = COMM – Assigns control of the drive via external control location EXT1 or EXT2 based on the fieldbus control word.</p> <ul style="list-style-type: none"> • Bit 5 of the Command Word 1 (parameter 0301) defines the active external control location (EXT1 or EXT2). • See Fieldbus user's manual for detailed instructions. <p>-1 = DI1(INV) – Assigns control to EXT1 or EXT2 based on the state of DI1 (DI1 activated = EXT1; DI1 de-activated = EXT2).</p> <p>-2...-6 = DI2(INV)...DI6(INV) – Assigns control to EXT1 or EXT2 based on the state of the selected digital input. See DI1(INV) above.</p>
1103	<p>REF1 SELECT</p> <p>Selects the signal source for external reference REF1.</p> <p>0 = KEYPAD – Defines the control panel as the reference source.</p> <p>1 = AI1 – Defines analog input 1 (AI1) as the reference source.</p> <p>2 = AI2 – Defines analog input 2 (AI2) as the reference source.</p> <p>3 = AI1/JOYST – Defines analog input 1 (AI1), configured for joystick operation, as the reference source.</p> <ul style="list-style-type: none"> • The minimum input signal runs the drive at the maximum reference in the reverse direction. Define the minimum using parameter 1104. • The maximum input signal runs the drive at maximum reference in the forward direction. Define the maximum using parameter 1105. • Requires parameter 1003 = 3 (REQUEST). <p>Warning! Because the low end of the reference range commands full reverse operation, do not use 0 V as the lower end of the reference range. Doing so means that if the control signal is lost (which is a 0 V input) the result is full reverse operation. Instead, use the following set-up so that loss of the analog input triggers a fault, stopping the drive:</p> <ul style="list-style-type: none"> • Set parameter 1301 MINIMUM AI1 (1304 MINIMUM AI2) at 20% (2 V or 4 mA). • Set parameter 3021 AI1 FAULT LIMIT to a value 5% or higher. • Set parameter 3001 AI<MIN FUNCTION to 1 (FAULT). <p>4 = AI2/JOYST – Defines analog input 2 (AI2), configured for joystick operation, as the reference source.</p> <ul style="list-style-type: none"> • See above (AI1/JOYST) description.

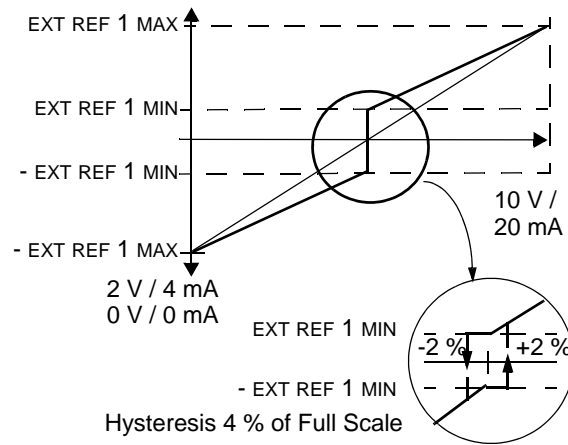

<p>5 = DI3U,4D(R) – Defines digital inputs as the frequency reference source (motor potentiometer control).</p> <ul style="list-style-type: none"> • Digital input DI3 increases the speed (the U stands for “up”). • Digital input DI4 decreases the speed (the D stands for “down”). • A Stop command resets the reference to zero (the R stands for “reset”). • Parameter 2205 ACCELER TIME 2 controls the reference signal's rate of change. <p>6 = DI3U,4D – Same as above (DI3U,4D(R)), except:</p> <ul style="list-style-type: none"> • A Stop command does not reset the reference to zero. The reference is stored. • When the drive restarts, the motor ramps up (at the selected acceleration rate) to the stored reference. <p>7 = DI5U,6D – Same as above (DI3U,4D), except that DI5 and DI6 are the digital inputs used.</p> <p>8 = COMM – Defines the fieldbus as the reference source.</p> <p>9 = COMM+AI1 – Defines a fieldbus and analog input 1 (AI1) combination as the reference source. See Analog Input Reference Correction below.</p> <p>10 = COMM*AI1 – Defines a fieldbus and analog input 1 (AI1) combination as the reference source. See Analog Input Reference Correction below.</p> <p>11 = DI3U, 4D(RNC) – Same as DI3U,4D(R) above, except that:</p> <ul style="list-style-type: none"> • Changing the control source (EXT1 to EXT2, EXT2 to EXT1, LOC to REM) does not copy the reference. <p>12 = DI3U,4D(NC) – Same as DI3U,4D above, except that:</p> <ul style="list-style-type: none"> • Changing the control source (EXT1 to EXT2, EXT2 to EXT1, LOC to REM) does not copy the reference. <p>13 = DI5U,6D(NC) – Same as DI5U,6D above, except that:</p> <ul style="list-style-type: none"> • Changing the control source (EXT1 to EXT2, EXT2 to EXT1, LOC to REM) does not copy the reference. <p>14 = AI1+AI2 – Defines an analog input 1 (AI1) and analog input 2 (AI2) combination as the reference source. See Analog Input Reference Correction below.</p> <p>15 = AI1*AI2 – Defines an analog input 1 (AI1) and analog input 2 (AI2) combination as the reference source. See Analog Input Reference Correction below.</p> <p>16 = AI1-AI2 – Defines an analog input 1 (AI1) and analog input 2 (AI2) combination as the reference source. See Analog Input Reference Correction below.</p> <p>17 = AI1/AI2 – Defines an analog input 1 (AI1) and analog input 2 (AI2) combination as the reference source. See Analog Input Reference Correction below.</p> <p>20 = KEYPAD(RNC) – Defines the control panel as the reference source. A stop command resets the reference to zero (R stands for reset). Changing the control source (EXT1 to EXT2, EXT2 to EXT1) does not copy the reference.</p> <p>21 = KEYPAD(NC) – Defines the control panel as the reference source. A stop command dose not reset the reference to zero. The reference is stored. Changing the control source (EXT1 to EXT2, EXT2 to EXT1) does not copy the reference.</p>

Analog Input Reference Correction

Parameter values 9, 10, and 14...17 use the formula in the following table.

Value Setting	AI reference is calculated as following:
C + B	C value + (B value - 50% of reference value)
C * B	C value * (B value / 50% of reference value)
C - B	(C value + 50% of reference value) - B value
C / B	(C value * 50% of reference value) / B value

Where:

- C = Main Reference value
(= COMM for values 9, 10 and = AI1 for values 14...17).
- B = Correcting reference
(= AI1 for values 9, 10 and = AI2 for values 14...17).

Example:

The figure shows the reference source curves for value settings 9, 10, and 14...17, where:

- C = 25%.
- P 4012 SETPOINT MIN = 0.
- P 4013 SETPOINT MAX = 0.
- B varies along the horizontal axis.

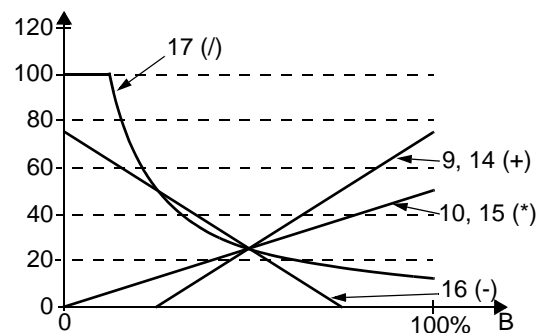

<p>1104</p>	<p>REF1 MIN Sets the minimum for external reference 1.</p> <ul style="list-style-type: none"> The minimum analog input signal (as a percent of the full signal in volts or amps) corresponds to REF1 MIN in Hz. Parameter 1301 MINIMUM AI1 or 1304 MINIMUM AI2 sets the minimum analog input signal. These parameters (reference and analog min. and max. settings) provide scale and offset adjustment for the reference. 	
<p>1105</p>	<p>REF1 MAX Sets the maximum for external reference 1.</p> <ul style="list-style-type: none"> The maximum analog input signal (as a percent of full the signal in volts or amps) corresponds to REF1 MAX in Hz. Parameter 1302 MAXIMUM AI1 or 1305 MAXIMUM AI2 sets the maximum analog input signal. 	
<p>1106</p>	<p>REF2 SELECT Selects the signal source for external reference REF2. 0...17 – Same as for parameter 1103 REF1 SELECT. 19 = PID1OUT – The reference is taken from the PID1 output. See Groups 40 and 41. 20, 21 – Same as for parameter 1103 REF1 SELECT.</p>	
<p>1107</p>	<p>REF2 MIN Sets the minimum for external reference 2.</p> <ul style="list-style-type: none"> The minimum analog input signal (in volts or amps) corresponds to REF2 MIN in %. Parameter 1301 MINIMUM AI1 or 1304 MINIMUM AI2 sets the minimum analog input signal. This parameter sets the minimum frequency reference. The value is a percentage of the: <ul style="list-style-type: none"> – maximum frequency. – maximum process reference 	
<p>1108</p>	<p>REF2 MAX Sets the maximum for external reference 2.</p> <ul style="list-style-type: none"> The maximum analog input signal (in volts or amps) corresponds to REF2 MAX in %. Parameter 1302 MAXIMUM AI1 or 1305 MAXIMUM AI2 sets the maximum analog input signal. This parameter sets the maximum frequency reference. The value is a percentage of the: <ul style="list-style-type: none"> – maximum frequency. – maximum process reference 	

Group 12: Constant Speeds

This group defines a set of constant speeds. In general:

- You can program up to 7 constant speeds.
- Values must be positive (No negative speed values for constant speeds).
- Constant speed selections are ignored if:
 - the process PID reference is followed, or
 - the drive is in local control mode, or
 - PFC (Pump-Fan Control) is active.

Note! Parameter 1208 CONST SPEED 7 acts also as a so-called fault speed which may be activated if the control signal is lost. For example, see parameters 3001 AI<MIN FUNCTION, 3002 PANEL COMM ERR and 3018 COMM FAULT FUNC.

Code	Description																																																			
1201	<p>CONST SPEED SEL Defines the digital inputs used to select Constant Speeds. See general comments in introduction. 0 = NOT SEL – Disables the constant speed function. 1 = DI1 – Selects Constant Speed 1 with digital input DI1. • Digital input activated = Constant Speed 1 activated. 2...6 = DI2...DI6 – Selects Constant Speed 1 with digital input DI2...DI6. See above. 7 = DI1,2 – Selects one of three Constant Speeds (1...3) using DI1 and DI2. • Uses two digital inputs, as defined below (0 = DI de-activated, 1 = DI activated):</p> <table border="1" style="margin-left: 20px;"> <thead> <tr> <th>DI1</th> <th>DI2</th> <th>Function</th> </tr> </thead> <tbody> <tr> <td>0</td> <td>0</td> <td>No constant speed</td> </tr> <tr> <td>1</td> <td>0</td> <td>Constant speed 1 (1202)</td> </tr> <tr> <td>0</td> <td>1</td> <td>Constant speed 2 (1203)</td> </tr> <tr> <td>1</td> <td>1</td> <td>Constant speed 3 (1204)</td> </tr> </tbody> </table> <p>• Can be set up as a so-called fault speed, which is activated if the control signal is lost. Refer to parameter 3001 AI<MIN function and parameter 3002 PANEL COMM ERR.</p> 8 = DI2,3 – Selects one of three Constant Speeds (1...3) using DI2 and DI3. • See above (DI1,2) for code. 9 = DI3,4 – Selects one of three Constant Speeds (1...3) using DI3 and DI4. • See above (DI1,2) for code. 10 = DI4,5 – Selects one of three Constant Speeds (1...3) using DI4 and DI5. • See above (DI1,2) for code. 11 = DI5,6 – Selects one of three Constant Speeds (1...3) using DI5 and DI6. • See above (DI1,2) for code. 12 = DI1,2,3 – Selects one of seven Constant Speeds (1...7) using DI1, DI2 and DI3. • Uses three digital inputs, as defined below (0 = DI de-activated, 1 = DI activated): <table border="1" style="margin-left: 20px;"> <thead> <tr> <th>DI1</th> <th>DI2</th> <th>DI3</th> <th>Function</th> </tr> </thead> <tbody> <tr> <td>0</td> <td>0</td> <td>0</td> <td>No constant speed</td> </tr> <tr> <td>1</td> <td>0</td> <td>0</td> <td>Constant speed 1 (1202)</td> </tr> <tr> <td>0</td> <td>1</td> <td>0</td> <td>Constant speed 2 (1203)</td> </tr> <tr> <td>1</td> <td>1</td> <td>0</td> <td>Constant speed 3 (1204)</td> </tr> <tr> <td>0</td> <td>0</td> <td>1</td> <td>Constant speed 4 (1205)</td> </tr> <tr> <td>1</td> <td>0</td> <td>1</td> <td>Constant speed 5 (1206)</td> </tr> <tr> <td>0</td> <td>1</td> <td>1</td> <td>Constant speed 6 (1207)</td> </tr> <tr> <td>1</td> <td>1</td> <td>1</td> <td>Constant speed 7 (1208)</td> </tr> </tbody> </table>	DI1	DI2	Function	0	0	No constant speed	1	0	Constant speed 1 (1202)	0	1	Constant speed 2 (1203)	1	1	Constant speed 3 (1204)	DI1	DI2	DI3	Function	0	0	0	No constant speed	1	0	0	Constant speed 1 (1202)	0	1	0	Constant speed 2 (1203)	1	1	0	Constant speed 3 (1204)	0	0	1	Constant speed 4 (1205)	1	0	1	Constant speed 5 (1206)	0	1	1	Constant speed 6 (1207)	1	1	1	Constant speed 7 (1208)
DI1	DI2	Function																																																		
0	0	No constant speed																																																		
1	0	Constant speed 1 (1202)																																																		
0	1	Constant speed 2 (1203)																																																		
1	1	Constant speed 3 (1204)																																																		
DI1	DI2	DI3	Function																																																	
0	0	0	No constant speed																																																	
1	0	0	Constant speed 1 (1202)																																																	
0	1	0	Constant speed 2 (1203)																																																	
1	1	0	Constant speed 3 (1204)																																																	
0	0	1	Constant speed 4 (1205)																																																	
1	0	1	Constant speed 5 (1206)																																																	
0	1	1	Constant speed 6 (1207)																																																	
1	1	1	Constant speed 7 (1208)																																																	

Code	Description																																																			
	<p>13 = DI3,4,5 – Selects one of seven Constant Speeds (1...7) using DI3, DI4 and DI5. • See above (DI1,2,3) for code.</p> <p>14 = DI4,5,6 – Selects one of seven Constant Speeds (1...7) using DI5, DI6 and DI7. • See above (DI1,2,3) for code.</p> <p>-1 = DI1(INV) – Selects Constant Speed 1 with digital input DI1. • Inverse operation: Digital input de-activated = Constant Speed 1 activated.</p> <p>-2...-6 = DI2(INV)...DI6(INV) – Selects Constant Speed 1 with digital input. See above.</p> <p>-7 = DI1,2(INV) – Selects one of three Constant Speeds (1...3) using DI1 and DI2. • Inverse operation uses two digital inputs, as defined below (0 = DI de-activated, 1 = DI activated):</p> <table border="1"> <thead> <tr> <th>DI1</th> <th>DI2</th> <th>Function</th> </tr> </thead> <tbody> <tr> <td>1</td> <td>1</td> <td>No constant speed</td> </tr> <tr> <td>0</td> <td>1</td> <td>Constant speed 1 (1202)</td> </tr> <tr> <td>1</td> <td>0</td> <td>Constant speed 2 (1203)</td> </tr> <tr> <td>0</td> <td>0</td> <td>Constant speed 3 (1204)</td> </tr> </tbody> </table> <p>-8 = DI2,3(INV) – Selects one of three Constant Speeds (1...3) using DI2 and DI2. • See above (DI1,2(INV)) for code.</p> <p>-9 = DI3,4(INV) – Selects one of three Constant Speeds (1...3) using DI3 and DI4. • See above (DI1,2(INV)) for code.</p> <p>-10 = DI4,5(INV) – Selects one of three Constant Speeds (1...3) using DI4 and DI5. • See above (DI1,2(INV)) for code.</p> <p>-11 = DI5,6(INV) – Selects one of three Constant Speeds (1...3) using DI5 and DI6. • See above (DI1,2(INV)) for code.</p> <p>-12 = DI1,2,3(INV) – Selects one of seven Constant Speeds (1...3) using DI1, DI2 and DI3. • Inverse operation uses three digital inputs, as defined below (0 = DI de-activated, 1 = DI activated):</p> <table border="1"> <thead> <tr> <th>DI1</th> <th>DI2</th> <th>DI3</th> <th>Function</th> </tr> </thead> <tbody> <tr> <td>1</td> <td>1</td> <td>1</td> <td>No constant speed</td> </tr> <tr> <td>0</td> <td>1</td> <td>1</td> <td>Constant speed 1 (1202)</td> </tr> <tr> <td>1</td> <td>0</td> <td>1</td> <td>Constant speed 2 (1203)</td> </tr> <tr> <td>0</td> <td>0</td> <td>1</td> <td>Constant speed 3 (1204)</td> </tr> <tr> <td>1</td> <td>1</td> <td>0</td> <td>Constant speed 4 (1205)</td> </tr> <tr> <td>0</td> <td>1</td> <td>0</td> <td>Constant speed 5 (1206)</td> </tr> <tr> <td>1</td> <td>0</td> <td>0</td> <td>Constant speed 6 (1207)</td> </tr> <tr> <td>0</td> <td>0</td> <td>0</td> <td>Constant speed 7 (1208)</td> </tr> </tbody> </table> <p>-13 = DI3,4,5(INV) – Selects one of seven Constant Speeds (1...3) using DI3, DI4 and DI5. • See above (DI1,2,3(INV)) for code.</p> <p>-14 = DI4,5,6(INV) – Selects one of seven Constant Speeds (1...3) using DI4, DI5 and DI6. • See above (DI1,2,3(INV)) for code.</p>	DI1	DI2	Function	1	1	No constant speed	0	1	Constant speed 1 (1202)	1	0	Constant speed 2 (1203)	0	0	Constant speed 3 (1204)	DI1	DI2	DI3	Function	1	1	1	No constant speed	0	1	1	Constant speed 1 (1202)	1	0	1	Constant speed 2 (1203)	0	0	1	Constant speed 3 (1204)	1	1	0	Constant speed 4 (1205)	0	1	0	Constant speed 5 (1206)	1	0	0	Constant speed 6 (1207)	0	0	0	Constant speed 7 (1208)
DI1	DI2	Function																																																		
1	1	No constant speed																																																		
0	1	Constant speed 1 (1202)																																																		
1	0	Constant speed 2 (1203)																																																		
0	0	Constant speed 3 (1204)																																																		
DI1	DI2	DI3	Function																																																	
1	1	1	No constant speed																																																	
0	1	1	Constant speed 1 (1202)																																																	
1	0	1	Constant speed 2 (1203)																																																	
0	0	1	Constant speed 3 (1204)																																																	
1	1	0	Constant speed 4 (1205)																																																	
0	1	0	Constant speed 5 (1206)																																																	
1	0	0	Constant speed 6 (1207)																																																	
0	0	0	Constant speed 7 (1208)																																																	
1202	<p>CONST SPEED 1 Sets value for Constant Speed 1. • The range depend on software option type. • Standare software: 0...500 HZ. • +N688: 0...50 HZ. • +N689: 0...55 HZ.</p>																																																			
1203 ... 1208	<p>CONST SPEED 2...CONST SPEED 7 Each sets a value for a Constant Speed. See CONST SPEED 1 above.</p>																																																			

Group 13: Analog Inputs

This group defines the limits and the filtering for analog inputs.

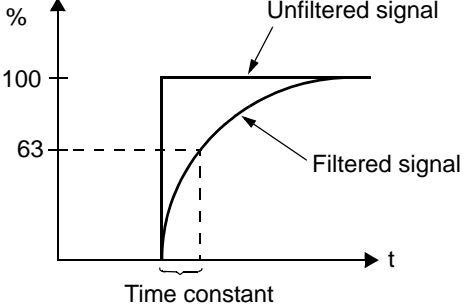
Code	Description
1301	<p>MINIMUM AI1</p> <p>Defines the minimum value of the analog input.</p> <ul style="list-style-type: none"> Define value as a percent of the full analog signal range. See example below. The minimum analog input signal corresponds to 1104 REF1 MIN or 1107 REF2 MIN. MINIMUM AI cannot be greater than MAXIMUM AI. These parameters (reference and analog min. and max. settings) provide scale and offset adjustment for the reference. See figure at parameter 1104. <p>Example. To set the minimum analog input value to 4 mA:</p> <ul style="list-style-type: none"> Configure the analog input for 0...20 mA current signal. Calculate the minimum (4 mA) as a percent of full range (20 mA) = $4 \text{ mA} / 20 \text{ mA} * 100\% = 20\%$
1302	<p>MAXIMUM AI1</p> <p>Defines the maximum value of the analog input.</p> <ul style="list-style-type: none"> Define value as a percent of the full analog signal range. The maximum analog input signal corresponds to 1105 REF1 MAX or 1108 REF2 MAX. See figure at parameter 1104.
1303	<p>FILTER AI1</p> <p>Defines the filter time constant for analog input 1 (AI1). The filtered signal reaches 63% of a step change within the time specified.</p> 
1304	<p>MINIMUM AI2</p> <p>Defines the minimum value of the analog input. Please See parameter 1302 MINIMUM AI1.</p>
1305	<p>MAXIMUM AI2</p> <p>Defines the maximum value of the analog input. Please See parameter 1302 MINIMUM AI1.</p>
1306	<p>FILTER AI2</p> <p>Defines the filter time constant for analog input 2 (AI2). Please See parameter 1303 FILTER AI1.</p>

Group 14: Relay Outputs

This group defines the condition that activates each of the relay outputs.

Code	Description
1401	<p>RELAY OUTPUT 1</p> <p>Defines the event or condition that activates relay 1 – what relay output 1 means.</p> <p>0 = NOT SEL – Relay is not used and is de-energized.</p> <p>1 = READY – Energize relay when drive is ready to function. Requires:</p> <ul style="list-style-type: none"> • Run enable signal present. • No faults exist. • Supply voltage is within range. • Emergency Stop command is not on. <p>2 = RUN – Energize relay when the drive is running.</p> <p>3 = FAULT (-1) – Energize relay when power is applied. De-energizes when a fault occurs.</p> <p>4 = FAULT – Energize relay when a fault is active.</p> <p>5 = ALARM – Energize relay when an alarm is active.</p> <p>6 = REVERSED – Energize relay when motor rotates in reverse direction.</p> <p>7 = STARTED – Energize relay when drive receives a start command (even if Run Enable signal is not present). De-energized relay when drive receives a stop command or a fault occurs.</p> <p>8 = SUPRV1 OVER – Energize relay when first supervised parameter (3201) exceeds the limit (3203).</p> <ul style="list-style-type: none"> • See "Group 32: Supervision" starting on page 105. <p>9 = SUPRV1 UNDER – Energize relay when first supervised parameter (3201) drops below the limit (3202).</p> <ul style="list-style-type: none"> • See "Group 32: Supervision" starting on page 105. <p>10 = SUPRV2 OVER – Energize relay when second supervised parameter (3204) exceeds the limit (3206).</p> <ul style="list-style-type: none"> • See "Group 32: Supervision" starting on page 105. <p>11 = SUPRV2 UNDER – Energize relay when second supervised parameter (3204) drops below the limit (3205).</p> <ul style="list-style-type: none"> • See "Group 32: Supervision" starting on page 105. <p>12 = SUPRV3 OVER – Energize relay when third supervised parameter (3207) exceeds the limit (3209).</p> <ul style="list-style-type: none"> • See "Group 32: Supervision" starting on page 105. <p>13 = SUPRV3 UNDER – Energize relay when third supervised parameter (3207) drops below the limit (3208).</p> <ul style="list-style-type: none"> • See "Group 32: Supervision" starting on page 105. <p>14 = AT SET POINT – Energize relay when the output frequency is equal to the reference frequency.</p> <p>15 = FAULT (RST) – Energize relay when the drive is in a fault condition and will reset after the programmed auto-reset delay.</p> <ul style="list-style-type: none"> • See parameter 3103 DELAY TIME. <p>16 = FLT/ALARM – Energize relay when fault or alarm occurs.</p> <p>17 = EXT CTRL – Energize relay when external control is selected.</p> <p>18 = REF 2 SEL – Energize relay when EXT2 is selected.</p> <p>19 = CONST FREQ – Energize relay when a constant speed is selected.</p> <p>20 = REF LOSS – Energize relay when reference or active control place is lost.</p> <p>21 = OVERCURRENT – Energize relay when an overcurrent alarm or fault occurs.</p> <p>22 = OVERVOLTAGE – Energize relay when an overvoltage alarm or fault occurs.</p> <p>23 = DRIVE TEMP – Energize relay when a drive or control board overtemperature alarm or fault occurs.</p> <p>24 = UNDERVOLTAGE – Energize relay when an undervoltage alarm or fault occurs.</p> <p>25 = AI1 LOSS – Energize relay when AI1 signal is lost.</p> <p>26 = AI2 LOSS – Energize relay when AI2 signal is lost.</p> <p>27 = MOTOR TEMP – Energize relay when a motor overtemperature alarm or fault occurs.</p> <p>28 = STALL – Energize relay when a stall alarm or fault exists.</p> <p>30 = PID SLEEP – Energize relay when the PID sleep function is active.</p> <p>31 = PFC – Use relay to start/stop motor in PFC control (See Group 81: PFC Control).</p> <ul style="list-style-type: none"> • Use this option only when PFC control is used. • Selection activated / deactivated when drive is not running. <p>32 = AUTOCHANGE – Energize relay when PFC autochange operation is performed.</p> <ul style="list-style-type: none"> • Use this option only when PFC control is used. <p>33 = FLUX READY – Energize relay when the motor is magnetized and able to supply nominal torque (motor has reached nominal magnetizing).</p> <p>34 = USER MACRO 2 – Energize relay when User Parameter Set 2 is active.</p>

Code	Description																																																																																																																																
	<p>35 = COMM – Energize relay based on input from fieldbus communication.</p> <ul style="list-style-type: none"> Fieldbus writes binary code in parameter 0134 that can energize relay 1...relay 6 according to the following: <table border="1"> <thead> <tr> <th>Par. 0134</th> <th>Binary</th> <th>RO6</th> <th>RO5</th> <th>RO4</th> <th>RO3</th> <th>RO2</th> <th>RO1</th> </tr> </thead> <tbody> <tr> <td>0</td> <td>000000</td> <td>0</td> <td>0</td> <td>0</td> <td>0</td> <td>0</td> <td>0</td> </tr> <tr> <td>1</td> <td>000001</td> <td>0</td> <td>0</td> <td>0</td> <td>0</td> <td>0</td> <td>1</td> </tr> <tr> <td>2</td> <td>000010</td> <td>0</td> <td>0</td> <td>0</td> <td>0</td> <td>1</td> <td>0</td> </tr> <tr> <td>3</td> <td>000011</td> <td>0</td> <td>0</td> <td>0</td> <td>0</td> <td>1</td> <td>1</td> </tr> <tr> <td>4</td> <td>000100</td> <td>0</td> <td>0</td> <td>0</td> <td>1</td> <td>0</td> <td>0</td> </tr> <tr> <td>5...62</td> <td>...</td> <td>...</td> <td>...</td> <td>...</td> <td>...</td> <td>...</td> <td>...</td> </tr> <tr> <td>63</td> <td>111111</td> <td>1</td> <td>1</td> <td>1</td> <td>1</td> <td>1</td> <td>1</td> </tr> </tbody> </table> <ul style="list-style-type: none"> 0 = De-energize relay, 1 = Energize relay. <p>36 = COMM(-1) – Energize relay based on input from fieldbus communication.</p> <ul style="list-style-type: none"> Fieldbus writes binary code in parameter 0134 that can energize relay 1...relay 6 according to the following: <table border="1"> <thead> <tr> <th>Par. 0134</th> <th>Binary</th> <th>RO6</th> <th>RO5</th> <th>RO4</th> <th>RO3</th> <th>RO2</th> <th>RO1</th> </tr> </thead> <tbody> <tr> <td>0</td> <td>000000</td> <td>1</td> <td>1</td> <td>1</td> <td>1</td> <td>1</td> <td>1</td> </tr> <tr> <td>1</td> <td>000001</td> <td>1</td> <td>1</td> <td>1</td> <td>1</td> <td>1</td> <td>0</td> </tr> <tr> <td>2</td> <td>000010</td> <td>1</td> <td>1</td> <td>1</td> <td>1</td> <td>0</td> <td>1</td> </tr> <tr> <td>3</td> <td>000011</td> <td>1</td> <td>1</td> <td>1</td> <td>1</td> <td>0</td> <td>0</td> </tr> <tr> <td>4</td> <td>000100</td> <td>1</td> <td>1</td> <td>1</td> <td>0</td> <td>1</td> <td>1</td> </tr> <tr> <td>5...62</td> <td>...</td> <td>...</td> <td>...</td> <td>...</td> <td>...</td> <td>...</td> <td>...</td> </tr> <tr> <td>63</td> <td>111111</td> <td>0</td> <td>0</td> <td>0</td> <td>0</td> <td>0</td> <td>0</td> </tr> </tbody> </table> <ul style="list-style-type: none"> 0 = De-energize relay, 1 = Energize relay. <p>45 = OVERRIDE – Energize relay when override mode is active. 46 = START DELAY – Energize relay when a start delay is active. 47 = USER LOAD C – Energize relay when a user load curve fault or alarm occurs.</p>	Par. 0134	Binary	RO6	RO5	RO4	RO3	RO2	RO1	0	000000	0	0	0	0	0	0	1	000001	0	0	0	0	0	1	2	000010	0	0	0	0	1	0	3	000011	0	0	0	0	1	1	4	000100	0	0	0	1	0	0	5...62	63	111111	1	1	1	1	1	1	Par. 0134	Binary	RO6	RO5	RO4	RO3	RO2	RO1	0	000000	1	1	1	1	1	1	1	000001	1	1	1	1	1	0	2	000010	1	1	1	1	0	1	3	000011	1	1	1	1	0	0	4	000100	1	1	1	0	1	1	5...62	63	111111	0	0	0	0	0	0
Par. 0134	Binary	RO6	RO5	RO4	RO3	RO2	RO1																																																																																																																										
0	000000	0	0	0	0	0	0																																																																																																																										
1	000001	0	0	0	0	0	1																																																																																																																										
2	000010	0	0	0	0	1	0																																																																																																																										
3	000011	0	0	0	0	1	1																																																																																																																										
4	000100	0	0	0	1	0	0																																																																																																																										
5...62																																																																																																																										
63	111111	1	1	1	1	1	1																																																																																																																										
Par. 0134	Binary	RO6	RO5	RO4	RO3	RO2	RO1																																																																																																																										
0	000000	1	1	1	1	1	1																																																																																																																										
1	000001	1	1	1	1	1	0																																																																																																																										
2	000010	1	1	1	1	0	1																																																																																																																										
3	000011	1	1	1	1	0	0																																																																																																																										
4	000100	1	1	1	0	1	1																																																																																																																										
5...62																																																																																																																										
63	111111	0	0	0	0	0	0																																																																																																																										
1402	<p>RELAY OUTPUT 2</p> <p>Defines the event or condition that activates relay 2 – what relay output 2 means. See 1401 RELAY OUTPUT 1.</p>																																																																																																																																
1403	<p>RELAY OUTPUT 3</p> <p>Defines the event or condition that activates relay 3 – what relay output 3 means. See 1401 RELAY OUTPUT 1.</p>																																																																																																																																
1404	<p>RO 1 ON DELAY</p> <p>Defines the switch-on delay for relay 1. On / off delays are ignored when relay output 1401 is set to PFC.</p>																																																																																																																																
1405	<p>RO 1 OFF DELAY</p> <p>Defines the switch-off delay for relay 1. On / off delays are ignored when relay output 1401 is set to PFC.</p>																																																																																																																																
1406	<p>RO 2 ON DELAY</p> <p>Defines the switch-on delay for relay 2. See RO 1 ON DELAY.</p>																																																																																																																																
1407	<p>RO 2 OFF DELAY</p> <p>Defines the switch-off delay for relay 2. See RO 1 OFF DELAY.</p>																																																																																																																																
1408	<p>RO 3 ON DELAY</p> <p>Defines the switch-on delay for relay 3. See RO 1 ON DELAY.</p>																																																																																																																																
1409	<p>RO 3 OFF DELAY</p> <p>Switch-off delay for relay 3. See RO 1 OFF DELAY.</p>																																																																																																																																

Code	Description
1410	RELAY OUTPUT 4...6
...	Defines the event or condition that activates relay 4...6 – what relay output 4...6 means.
1412	See 1401 RELAY OUTPUT 1.
1413	RO 4 ON DELAY Defines the switch-on delay for relay 4. See RO 1 ON DELAY.
1414	RO 4 OFF DELAY Defines the switch-off delay for relay 4. See RO 1 OFF DELAY.
1415	RO 5 ON DELAY Defines the switch-on delay for relay 5. See RO 1 ON DELAY.
1416	RO 5 OFF DELAY Defines the switch-off delay for relay 5. See RO 1 OFF DELAY.
1417	RO 6 ON DELAY Defines the switch-on delay for relay 6. See RO 1 ON DELAY.
1418	RO 6 OFF DELAY Defines the switch-off delay for relay 6. See RO 1 OFF DELAY.

Group 15: Analog Outputs

This group defines the drive's analog (current signal) outputs. The drive's analog outputs can be:

- Any parameter of the Operating Data group (Group 01).
- Limited to programmable minimum and maximum values of output current.
- Scaled (and/or inverted) by defining the minimum and maximum values of the source parameter (or content). Defining an maximum value (parameter 1503 or 1509) that is less than the content minimum value (parameter 1502 or 1508) results in an inverted output.
- Filtered.

Code	Description
1501	<p>AO1 CONTENT SEL Defines the content for analog output AO1. 99 = EXCITE PTC – Provides a current source for sensor type PTC. Output = 1.6 mA. See Group 35. 100 = EXCITE PT100 – Provides a current source for sensor type Pt100. Output = 9.1 mA. See Group 35. 101...159 – Output corresponds to a parameter in the Operating Data group (Group 01). Parameter defined by value (value 102 = parameter 0102)</p>
1502	<p>AO1 CONTENT MIN Sets the minimum content value. • Content is the parameter selected by parameter 1501. • Minimum value refers to the minimum content value that will be converted to an analog output. • These parameters (content and current min. and max. settings) provide scale and offset adjustment for the output. See figure.</p>
1503	<p>AO1 CONTENT MAX Sets the maximum content value • Content is the parameter selected by parameter 1501. • Maximum value refers to the maximum content value that will be converted to an analog output.</p>
1504	<p>MINIMUM AO1 Sets the minimum output current.</p>
1505	<p>MAXIMUM AO1 Sets the maximum output current.</p>
1506	<p>FILTER AO1 Defines the filter time constant for AO1. • The filtered signal reaches 63% of a step change within the time specified. • See figure in parameter 1303.</p>
1507	<p>AO2 CONTENT SEL Defines the content for analog output AO2. See AO1 CONTENT SEL above.</p>
1508	<p>AO2 CONTENT MIN Sets the minimum content value. See AO1 CONTENT MIN above.</p>
1509	<p>AO2 CONTENT MAX Sets the maximum content value. See AO1 CONTENT MAX above.</p>
1510	<p>MINIMUM AO2 Sets the minimum output current. See MINIMUM AO1 above.</p>
1511	<p>MAXIMUM AO2 Sets the maximum output current. See MAXIMUM AO1 above.</p>

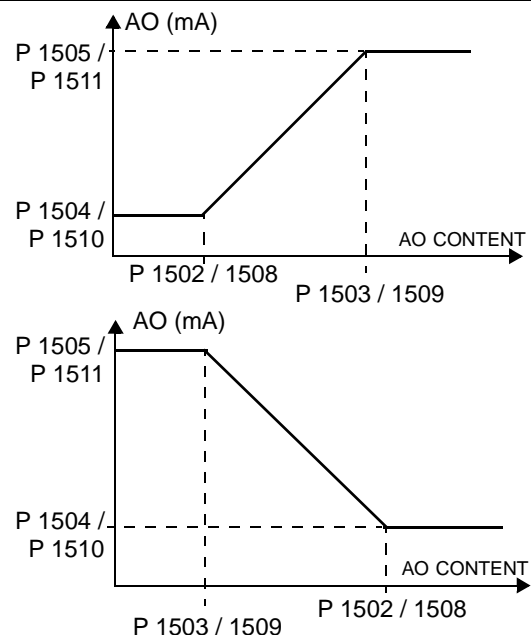

Code	Description
1512	FILTER AO2 Defines the filter time constant for AO2. See FILTER AO1 above.

Group 16: System Controls

This group defines a variety of system level locks, resets and enables.

Code	Description
1601	<p>RUN ENABLE</p> <p>Selects the source of the run enable signal.</p> <p>0 = NOT SEL – Allows the drive to start without an external run enable signal.</p> <p>1 = DI1 – Defines digital input DI1 as the run enable signal.</p> <ul style="list-style-type: none"> This digital input must be activated for run enable. If the voltage drops and de-activates this digital input, the drive will coast to stop and not start until the run enable signal resumes. <p>2...6 = DI2...DI6 – Defines digital input DI2...DI6 as the run enable signal.</p> <ul style="list-style-type: none"> See DI1 above. <p>7 = COMM – Assigns the fieldbus Command Word as the source for the run enable signal.</p> <ul style="list-style-type: none"> Bit 6 of the Command Word 1 (parameter 0301) activates the run disable signal. See fieldbus user's manual for detailed instructions. <p>-1 = DI1(INV) – Defines an inverted digital input DI1 as the run enable signal.</p> <ul style="list-style-type: none"> This digital input must be de-activated for run enable. If this digital input activates, the drive will coast to stop and not start until the run enable signal resumes. <p>-2...-6 = DI2(INV)...DI6(INV) – Defines an inverted digital input DI2...DI6 as the run enable signal.</p> <ul style="list-style-type: none"> See DI1(INV) above.
1602	<p>PARAMETER LOCK</p> <p>Determines if the control panel can change parameter values.</p> <ul style="list-style-type: none"> This lock does not limit parameter changes made by macros. This lock does not limit parameter changes written by fieldbus inputs. This parameter value can be changed only if the correct pass code is entered. See parameter 1603 PASS CODE. <p>0 = LOCKED – You cannot use the control panel to change parameter values.</p> <ul style="list-style-type: none"> The lock can be opened by entering the valid pass code to parameter 1603. <p>1 = OPEN – You can use the control panel to change parameter values.</p> <p>2 = NOT SAVED – You can use the control panel to change parameter values, but they are not stored in permanent memory.</p> <ul style="list-style-type: none"> Set parameter 1607 PARAM SAVE to 1 (SAVE) to store changed parameter values to memory.
1603	<p>PASS CODE</p> <p>Entering the correct pass code allows you to change the parameter lock.</p> <ul style="list-style-type: none"> See parameter 1602 above. The code 358 allows you to change the value of the parameter 1602 once. This entry reverts back to 0 automatically.
1604	<p>FAULT RESET SEL</p> <p>Selects the source for the fault reset signal. The signal resets the drive after a fault trip if the cause of the fault no longer exists.</p> <p>0 = KEYPAD – Defines the control panel as the only fault reset source.</p> <ul style="list-style-type: none"> Fault reset is always possible with control panel. <p>1 = DI1 – Defines digital input DI1 as a fault reset source.</p> <ul style="list-style-type: none"> Activating the digital input resets the drive. <p>2...6 = DI2...DI6 – Defines digital input DI2...DI6 as a fault reset source.</p> <ul style="list-style-type: none"> See DI1 above. <p>7 = START/STOP – Defines the Stop command as a fault reset source.</p> <ul style="list-style-type: none"> Do not use this option when fieldbus communication provides the start, stop and direction commands. <p>8 = COMM – Defines the fieldbus as a fault reset source.</p> <ul style="list-style-type: none"> The Command Word is supplied through fieldbus communication. The bit 4 of the Command Word 1 (parameter 0301) resets the drive. <p>-1 = DI1(INV) – Defines an inverted digital input DI1 as a fault reset source.</p> <ul style="list-style-type: none"> De-activating the digital input resets the drive. <p>-2...-6 = DI2(INV)...DI6(INV) – Defines an inverted digital input DI2...DI6 as a fault reset source.</p> <ul style="list-style-type: none"> See DI1(INV) above.

Code	Description
1605	<p>USER PAR SET CHG</p> <p>Defines control for changing the user parameter set.</p> <ul style="list-style-type: none"> • See parameter 9902 APPLIC MACRO. • The drive must be stopped to change User Parameter Sets. • During a change, the drive will not start. <p>Note: Always save the User Parameter Set after changing any parameter settings, or performing a motor identification.</p> <ul style="list-style-type: none"> • Whenever the power is cycled, or parameter 9902 APPLIC MACRO is changed, the drive loads the last settings saved. Any unsaved changes to a user parameter set are lost. <p>Note: The value of this parameter (1605) is not included in the User Parameter Sets, and it does not change if User Parameter Sets change.</p> <p>Note: You can use a relay output to supervise the selection of User Parameter Set 2.</p> <ul style="list-style-type: none"> • See parameter 1401. <p>0 = NOT SEL – Defines the control panel (using parameter 9902) as the only control for changing User Parameter Sets.</p> <p>1 = DI1 – Defines digital input DI1 as a control for changing User Parameter Sets.</p> <ul style="list-style-type: none"> • The drive loads User Parameter Set 1 on the falling edge of the digital input. • The drive loads User Parameter Set 2 on the rising edge of the digital input. • The User Parameter Set changes only when the drive is stopped. <p>2...6 = DI2...DI6 – Defines digital input DI2...DI6 as a control for changing User Parameter Sets.</p> <ul style="list-style-type: none"> • See DI1 above. <p>-1 = DI1(INV) – Defines an inverted digital input DI1 as a control for changing User Parameter Sets.</p> <ul style="list-style-type: none"> • The drive loads User Parameter Set 1 on the rising edge of the digital input. • The drive loads User Parameter Set 2 on the falling edge of the digital input. • The User Parameter Set changes only when the drive is stopped. <p>-2...-6 = DI2(INV)...DI6(INV) – Defines an inverted digital input DI2...DI6 as a control for changing User Parameter Sets.</p> <ul style="list-style-type: none"> • See DI1(INV) above.
1606	<p>LOCAL LOCK</p> <p>Defines control for the use of the LOC mode. The LOC mode allows drive control from the control panel.</p> <ul style="list-style-type: none"> • When LOCAL LOCK is active, the control panel cannot change to LOC mode. <p>0 = NOT SEL – Disables the lock. The control panel can select LOC and control the drive.</p> <p>1 = DI1 – Defines digital input DI1 as the control for setting the local lock.</p> <ul style="list-style-type: none"> • Activating the digital input locks out local control. • De-activating the digital input enable the LOC selection. <p>2...6 = DI2...DI6 – Defines digital input DI2...DI6 as the control for setting the local lock.</p> <ul style="list-style-type: none"> • See DI1 above. <p>7 = ON – Sets the lock. The control panel cannot select LOC, and cannot control the drive.</p> <p>8 = COMM – Defines bit 14 of the Command Word 1 as the control for setting the local lock.</p> <ul style="list-style-type: none"> • The Command Word is supplied through fieldbus communication. • The Command Word is 0301. <p>-1 = DI1(INV) – Defines an inverted digital input DI1 as the control for setting the local lock.</p> <ul style="list-style-type: none"> • De-activating the digital input locks out local control. • Activating the digital input enable the LOC selection. <p>-2...-6 = DI2(INV)...DI6(INV) – Defines an inverted digital input DI2...DI6 as the control for setting the local lock.</p> <ul style="list-style-type: none"> • See DI1(INV) above.
1607	<p>PARAM SAVE</p> <p>Saves all altered parameters to permanent memory.</p> <ul style="list-style-type: none"> • Parameters altered through a fieldbus are not automatically saved to permanent memory. To save, you must use this parameter. • If 1602 PARAMETER LOCK = 2 (NOT SAVED), parameters altered from the control panel are not saved. To save, you must use this parameter. • If 1602 PARAMETER LOCK = 1 (OPEN), parameters altered from the control panel are stored immediately to permanent memory. <p>0 = DONE – Value changes automatically when all parameters are saved.</p> <p>1 = SAVE – Saves altered parameters to permanent memory.</p>

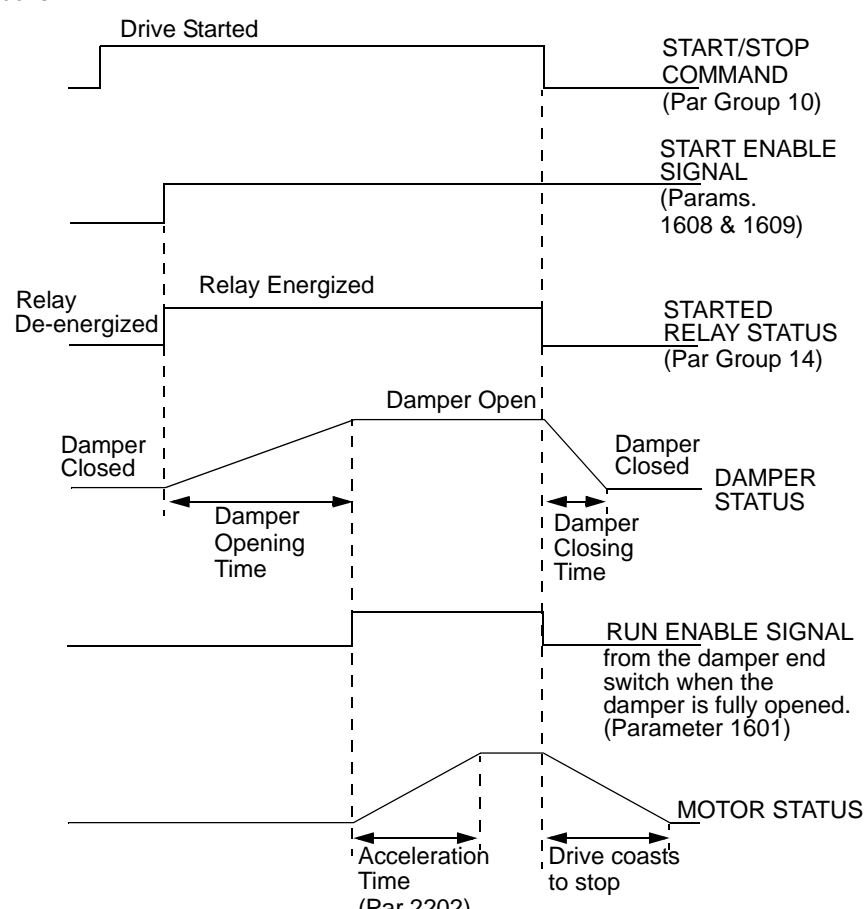
Code	Description
1608	<p>START ENABLE 1</p> <p>Selects the source of the start enable 1 signal.</p> <p>Note: Start enable functionality differs from the run enable functionality.</p> <p>0 = NOT SEL – Allows the drive to start without an external start enable signal.</p> <p>1 = DI1 – Defines digital input DI1 as the start enable 1 signal.</p> <ul style="list-style-type: none"> This digital input must be activated for start enable 1 signal. If the voltage drops and de-activates this digital input, the drive will coast to stop and show alarm 2021 on the panel display. The drive will not start until start enable 1 signal resumes. <p>2...6 = DI2...DI6 – Defines digital input DI2...DI6 as the start enable 1 signal.</p> <ul style="list-style-type: none"> See DI1 above. <p>7 = COMM – Assigns the fieldbus Command Word as the source for the start enable 1 signal.</p> <ul style="list-style-type: none"> Bit 2 of the Command word 2 (parameter 0302) activates the start disable 1 signal. See fieldbus user's manual for detailed instructions. <p>(-1) = DI1 (INV) – Defines an inverted digital input DI1 as the start enable 1 signal.</p> <p>(-2)...(-6) = DI2 (INV)...DI6 (INV) – Defines an inverted digital input DI2...DI6 as the start enable 1 signal.</p> <ul style="list-style-type: none"> See DI1 (INV) above.  <p>The diagram illustrates the timing sequence for starting the drive with a damper. It shows several digital signals: START/STOP COMMAND (Par Group 10), START ENABLE SIGNAL (Params. 1608 & 1609), STARTED RELAY STATUS (Par Group 14), DAMPER STATUS, and RUN ENABLE SIGNAL (from the damper end switch when the damper is fully opened, Parameter 1601). The MOTOR STATUS signal shows the drive's acceleration and coasting phases. Key time intervals are labeled: Damper Opening Time, Acceleration Time (Par 2202), Damper Closing Time, and Drive coasts to stop.</p>

Code	Description
1609	<p>START ENABLE 2</p> <p>Selects the source of the start enable 2 signal.</p> <p>Note: Start enable functionality differs from the run enable functionality.</p> <p>0 = NOT SEL – Allows the drive to start without an external start enable signal.</p> <p>1 = DI1 – Defines digital input DI1 as the start enable 2 signal.</p> <ul style="list-style-type: none"> • This digital input must be activated as the start enable 2 signal. • If the voltage drops and de-activates this digital input, the drive will coast to stop and show alarm 2022 on panel display. The drive will not start until start enable 2 signal resumes. <p>2...6 = DI2...DI6 – Defines digital input DI2...DI6 as the start enable 2 signal.</p> <ul style="list-style-type: none"> • See DI1 above. <p>7 = COMM – Assigns the fieldbus Command Word as the source for the start enable 2 signal. Bit 3 of the Command word 2 (parameter 0302) activates the start disable 2 signal.</p> <ul style="list-style-type: none"> • See fieldbus user's manual for detailed instructions. <p>(-1) = DI1(INV) – Defines an inverted digital input DI1 as the start enable 2 signal.</p> <p>(-2)...(-6) = DI2(INV)...DI6(INV) – Defines an inverted digital input DI2...DI6 as the start enable 2 signal.</p> <ul style="list-style-type: none"> • See DI1 (INV) above.
1610	<p>DISPLAY ALARMS</p> <p>Controls the visibility of the following alarms:</p> <ul style="list-style-type: none"> • 2001, Overcurrent alarm • 2002, Overvoltage alarm • 2003, Undervoltage alarm • 2009, Device overtemperature alarm <p>0 = NO – The above alarms are suppressed.</p> <p>1 = YES – All of the above alarms are enabled.</p>

Group 17: Override

This group defines the source for the override activation signal, the override speed/frequency and pass code and how the override is enabled and disabled.

Warning! When override DI is activated, the normal control of the drive using the panel or I/O interface is not possible. See the explanation below. Ensure this will not cause any danger in the application. Note also that the drive is out of the factory warranty when it is in the override mode.

When override DI is activated, the drive stops and then accelerates to the preset speed or frequency. When the DI is deactivated the drive stops and reboots.

When override is active:

- Drive runs at preset speed
- Drive ignores all keypad commands
- Drive ignores all commands from communication links
- Drive ignores all digital inputs except override activation/deactivation.
- Drive displays alarm message "2020 OVERRIDE MODE"

Following faults are ignored:

3	DEVICE OVERTEMP
5	OVERLOAD
6	DC UNDERVOLT
7	AI1 LOSS
8	AI2 LOSS
9	MOTOR TEMP
10	PANEL LOSS
12	MOTOR STALL
14	EXTERNAL FLT 1
15	EXTERNAL FLT 2
17	UNDERLOAD
18	THERM FAIL
21	CURR MEAS
22	SUPPLY PHASE
28	SERIAL 1 ERR
29	EFB CONFIG FILE
30	FORCE TRIP
31	EFB 1
32	EFB 2
33	EFB 3
34	MOTOR PHASE
1001	PAR PFC REFNEG
1002	PAR PFC IOCONF

1003	PAR AI SCALE
1004	PAR AO SCALE
1006	PAR EXTROMISSING
1007	PAR FBUSMISSING

Commissioning the override mode:

1. Enter the parameters in all groups as needed, except group 17.
2. Select the digital input that will activate override mode P1701.
3. Enter the frequency reference for override mode, P1702.
4. Enter the pass code P1704 (358).
5. Enable the override mode P1705.

Changing the override parameters:

1. If override mode is already enabled, disable it:
 - Enter the pass code P1704.
 - Disable the override mode P1705.
2. If needed, load the override parameter set P9902.
3. Change the parameters as needed, except group 17.
4. Change the parameters in group 17 as needed:
 - Digital input for override mode P1701.
 - Frequency reference P1702.
5. Enter the pass code P1704.
6. Enable the override mode P1705. The drive replaces the override parameter set with new values of all parameters.

Code	Description
1701	<p>VERRIDE SEL Selects the source of the override activation signal. 0 = NOT SEL - Override activation signal not selected. 1 = DI1 - Defines digital input DI1 as the override activation signal. • This digital input must be activated for override activation signal. 2...6 = DI2...DI6 - Defines digital input DI2...DI6 as the override activation signal. • See DI1 above. (-1) = DI1(INV) - Defines an inverted digital input DI1 as the override activation signal. (-2)...(-6) = DI2 (INV)...DI6(INV) - Defines an inverted digital input DI2...DI6 as the override activation signal. • See DI1 (INV) above.</p>
1702	<p>VERRIDE FREQ Defines a preset frequency for the override.</p>

Code	Description
1704	<p>VERRIDE PASS CODE Entering the correct pass code unlocks parameter 1705 for one change.</p> <ul style="list-style-type: none"> • Enter the pass code always before changing the value of the parameter 1705. • See parameter 1705 below. • The pass code is 358. • The entry reverts back to zero automatically.
1705	<p>VERRIDE ENABLE Selects whether the override is enabled or disabled..</p> <p>0 = OFF - Override disabled. 1 = ON - Override enabled. 2 = LOAD - Loads a previously saved Override Para set to be the active Para of the drive.</p> <ul style="list-style-type: none"> • When enabled, the drive stores the values of all parameters into an override parameter set (see parameter 9902) and the parameters in Group 17 will be write protected (except parameter 1704). To change the other parameters in the Group 17, override has to be disabled.
1706	<p>VERRIDE DIR Selects the source of the override direction signal.</p> <p>0 = FORWARD – Assigns forward as the override direction. 1 = DI1 – Defines digital input DI1 as the override direction signal.</p> <ul style="list-style-type: none"> • Activating the digital input selects the forward direction. • De-activating the digital input selects the reverse direction. <p>2...6 = DI2...DI6 – Defines digital input DI1... DI6 as the override direction signal.</p> <ul style="list-style-type: none"> • See DI1 above. <p>7 = REVERSE – Assigns reverse as the override direction. -1 = DI1 (INV) – Defines an inverted digital input DI1 as the override direction signal.</p> <ul style="list-style-type: none"> • De-activating the digital input selects the forward direction. • Activating the digital input selects the reverse direction. <p>-2...-6 = DI2 (INV) ...DI6 (INV) – Defines an inverted digital input DI1... DI6 as the override direction signal.</p> <ul style="list-style-type: none"> • See DI1(INV) above.
1707	<p>VERRIDE REF Selects the source of the override reference.</p> <p>1 = CONSTANT – Selects a preset frequency or speed for the override. The frequency value is defined by parameter 1702 OVERRIDE FREQ and the speed value by parameter 1703 OVERRIDE SPEED. 2 = PID – The reference is taken from the PID output, see group 40 PROCESS PID SET1.</p> <ul style="list-style-type: none"> • Note: The following conditions must be met when using PID in the override mode: <ul style="list-style-type: none"> • PID1 set point (parameter 4010 SET POINT SEL) can be either A1, A2 or INTERNAL. • PID1 parameter set 1 must be active (parameter 4027 PID 1 PARAM SET = SET 1). • Override direction (parameter 1706 OVERRIDE DIR) can be either 0 = FORWARD or 7 = REVERSE.

Group 20: Limits

This group defines minimum and maximum limits to follow in driving the motor – frequency, current, etc.

Code	Description
2003	<p>MAX CURRENT Defines the maximum output current (A) supplied by the drive to the motor.</p>
2005	<p>OVERVOLT CTRL Sets the DC overvoltage controller on or off. Fast braking of a high inertia load causes the DC bus voltage to rise to the overvoltage control limit. To prevent the DC voltage from exceeding the trip limit, the overvoltage controller automatically decreases the braking torque by increasing output frequency. 0 = DISABLE – Disables controller. 1 = ENABLE – Enables controller Warning! If a braking chopper or a braking resistor is connected to the drive, this parameter value must be set to 0 to ensure proper operation of the chopper.</p>
2006	<p>UNDERVOLT CTRL Sets the DC undervoltage controller on or off. When on: <ul style="list-style-type: none"> • If the DC bus voltage drops due to loss of input power, the undervoltage controller decreases the motor speed in order to keep the DC bus voltage above the lower limit. • When the motor speed decreases, the inertia of the load causes regeneration back into the drive, keeping the DC bus charged, and preventing an undervoltage trip. • The DC undervoltage controller increases power loss ride-through on systems with a high inertia, such as a centrifuge or a fan. 0 = DISABLE – Disables controller. 1 = ENABLE (TIME) – Enables controller with 500 ms time limit for operation. 2 = ENABLE – Enables controller without maximum time limit for operation.</p>
2007	<p>MINIMUM FREQ Defines the minimum limit for the drive output frequency. <ul style="list-style-type: none"> • A positive or zero minimum frequency value defines two ranges, one positive and one negative. • A negative minimum frequency value defines one speed range. See figure. Note! Keep MINIMUM FREQ ≤ MAXIMUM FREQ.</p>
2008	<p>MAXIMUM FREQ Defines the maximum limit for the drive output frequency.</p>

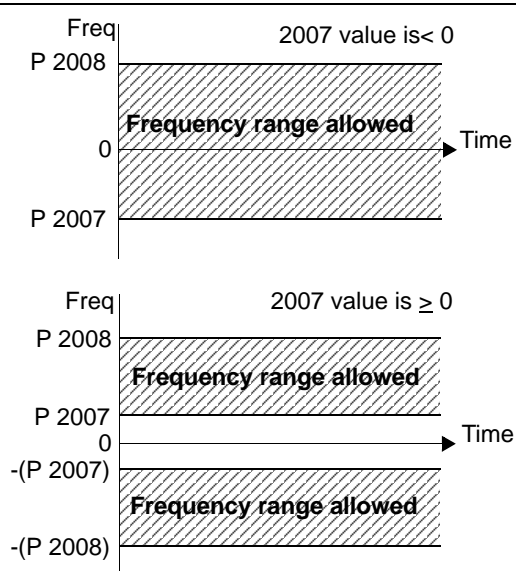

Group 21: Start/Stop

This group defines how the motor starts and stops. The ACS510 supports several start and stop modes.

Code	Description
2101	<p>START FUNCTION</p> <p>Selects the motor start method.</p> <p>1 = AUTO – Selects the automatic start mode.</p> <p>2 = DC MAGN – Selects the DC Magnetizing start mode.</p> <p>Note! Mode cannot start a rotating motor.</p> <p>Note! The drive starts when the set pre-magnetizing time (param. 2103) has passed, even if motor magnetization is not complete.</p> <ul style="list-style-type: none"> • Magnetizes the motor within the time determined by the parameter 2103 DC MAGN TIME using DC current. The normal control is released exactly after the magnetizing time. <p>3 = SCALAR FLYSTART – Selects the flying start mode.</p> <ul style="list-style-type: none"> • The drive automatically selects the correct output frequency to start a rotating motor – useful if the motor is already rotating and if the drive will start smoothly at the current frequency. <p>4 = TORQ BOOST – Selects the automatic torque boost mode .</p> <ul style="list-style-type: none"> • May be necessary in drives with high starting torque. • Torque boost is only applied at start, ending when output frequency exceeds 20 Hz or when output frequency is equal to reference. • In the beginning the motor magnetizes within the time determined by the parameter 2103 DC MAGN TIME using DC current. • See parameter 2110 TORQ BOOST CURR. <p>5 = FLY + TORQ BOOST – Selects both the flying start and the torque boost mode .</p> <ul style="list-style-type: none"> • Flying start routine is performed first and the motor is magnetized. If the speed is found to be zero, the torque boost is done. <p>8 = RAMP – Immediate start from zero frequency.</p>
2102	<p>STOP FUNCTION</p> <p>Selects the motor stop method.</p> <p>1 = COAST – Selects cutting off the motor power as the stop method. The motor coasts to stop.</p> <p>2 = RAMP – Selects using a deceleration ramp</p> <ul style="list-style-type: none"> • Deceleration ramp is defined by 2203 DECELER TIME 1 or 2206 DECELER TIME 2 (whichever is active).
2103	<p>DC MAGN TIME</p> <p>Defines the pre-magnetizing time for the DC Magnetizing start mode.</p> <ul style="list-style-type: none"> • Use parameter 2101 to select the start mode. • After the start command, the drive pre-magnetizes the motor for the time defined here, and then starts the motor. • Set the pre-magnetizing time just long enough to allow full motor magnetization. Too long a time heats the motor excessively.
2104	<p>DC CURR CTL</p> <p>Selects whether DC current is used for braking or DC Hold.</p> <p>0 = NOT SEL – Disables the DC current operation.</p> <p>2 = DC BRAKING – Enables the DC Injection Braking after modulation has stopped.</p> <ul style="list-style-type: none"> • If parameter 2102 STOP FUNCTION is 1 (COAST), braking is applied after start is removed. • If parameter 2102 STOP FUNCTION is 2 (RAMP), braking is applied after ramp.
2106	<p>DC CURR REF</p> <p>Defines the DC current control reference as a percentage of parameter 9906 MOTOR NOM CURR.</p>
2107	<p>DC BRAKE TIME</p> <p>Defines the DC brake time after modulation has stopped, if parameter 2104 is 2 (DC BRAKING).</p>

Code	Description
2108	<p>START INHIBIT</p> <p>Sets the Start inhibit function on or off. The Start inhibit function ignores a pending start command in any of the following situations (a new start command is required):</p> <ul style="list-style-type: none"> • A fault is reset. • Run Enable (parameter 1601) activates while start command is active. • Mode changes from local to remote. • Control switches from EXT1 to EXT2. • Control switches from EXT2 to EXT1. <p>0 = OFF – Disables the Start inhibit function. 1 = ON – Enables the Start inhibit function.</p>
2109	<p>EMERG STOP SEL</p> <p>Defines control of the Emergency stop command. When activated:</p> <ul style="list-style-type: none"> • Emergency stop decelerates the motor using the emergency stop ramp (parameter 2208 EMERG DEC TIME). • Requires an external stop command and removal of the emergency stop command before drive can restart. <p>0 = NOT SEL – Disables the Emergency stop function through digital inputs. 1 = DI1 – Defines digital input DI1 as the control for Emergency stop command.</p> <ul style="list-style-type: none"> • Activating the digital input issues an Emergency stop command. • De-activating the digital input removes the Emergency stop command. <p>2...6 = DI2...DI6 – Defines digital input DI2...DI6 as the control for Emergency stop command.</p> <ul style="list-style-type: none"> • See DI1 above. <p>-1 = DI1(INV) – Defines an inverted digital input DI1 as the control for Emergency stop command.</p> <ul style="list-style-type: none"> • De-activating the digital input issues an Emergency stop command. • Activating the digital input removes the Emergency stop command. <p>-2...-6 = DI2(INV)...DI6(INV) – Defines an inverted digital input DI2...DI6 as the control for Emergency stop command.</p> <ul style="list-style-type: none"> • See DI1(INV) above.
2110	<p>TORQ BOOST CURR</p> <p>Sets the maximum supplied current during torque boost. See parameter 2101 START FUNCTION.</p>
2113	<p>START DELAY</p> <p>Defines the Start delay. After the conditions for start have been fulfilled, the drive waits until the delay has elapsed and then starts the motor. Start delay can be used with all start modes.</p> <ul style="list-style-type: none"> • If START DELAY = ZERO, the delay is disabled. • During the start delay, alarm 2028 START DELAY is shown.

Group 22: Accel/Decel

This group defines ramps that control the rate of acceleration and deceleration. You define these ramps as a pair, one for acceleration and one for deceleration. You can define two pairs of ramps and use a digital input to select one or the other pair.

Code	Description
2201	<p>ACC/DEC 1/2 SEL</p> <p>Defines control for selection of acceleration/deceleration ramps.</p> <ul style="list-style-type: none"> Ramps are defined in pairs, one each for acceleration and deceleration. See below for the ramp definition parameters. <p>0 = NOT SEL – Disables selection, the first ramp pair is used.</p> <p>1 = DI1 – Defines digital input DI1 as the control for ramp pair selection.</p> <ul style="list-style-type: none"> Activating the digital input selects ramp pair 2. De-activating the digital input selects ramp pair 1. <p>2...6 = DI2...DI6 – Defines digital input DI2...DI6 as the control for ramp pair selection.</p> <ul style="list-style-type: none"> See DI1 above. <p>7 = COMM – Defines bit 10 of the Command Word 1 as the control for ramp pair selection.</p> <ul style="list-style-type: none"> The Command Word is parameter 0301, which is supplied through fieldbus communication. <p>-1 = DI1(INV) – Defines an inverted digital input DI1 as the control for ramp pair selection.</p> <ul style="list-style-type: none"> De-activating the digital input selects ramp pair 2 Activating the digital input selects ramp pair 1. <p>-2...-6 = DI2(INV)...DI6(INV) – Defines an inverted digital input DI2...DI6 as the control for ramp pair selection.</p> <ul style="list-style-type: none"> See DI1(INV) above.
2202	<p>ACCELER TIME 1</p> <p>Sets the acceleration time for zero to maximum frequency for ramp pair 1. See A in figure.</p> <ul style="list-style-type: none"> Actual acceleration time also depends on 2204 RAMP SHAPE 1. See 2008 MAXIMUM FREQ.
2203	<p>DECELER TIME 1</p> <p>Sets the deceleration time for maximum frequency to zero for ramp pair 1.</p> <ul style="list-style-type: none"> Actual deceleration time also depends on 2204 RAMP SHAPE 1. See 2008 MAXIMUM FREQ.
2204	<p>RAMP SHAPE 1</p> <p>Selects the shape of the acceleration/deceleration ramp for ramp pair 1. See B in figure.</p> <ul style="list-style-type: none"> Shape is defined as a ramp, unless additional time is specified here to reach the maximum frequency. A longer time provides a softer transition at each end of the slope. The shape becomes an s-curve. Rule of thumb: 1/5 is a suitable relation between the ramp shape time and the acceleration ramp time. <p>0.0 = LINEAR – Specifies linear acceleration/deceleration ramps for ramp pair 1.</p> <p>0.1...1000.0 = S-CURVE – Specifies s-curve acceleration/deceleration ramps for ramp pair 1.</p>
2205	<p>ACCELER TIME 2</p> <p>Sets the acceleration time (s) for zero to maximum frequency for ramp pair 2. See 2202 ACCELER TIME 1.</p>
2206	<p>DECELER TIME 2</p> <p>Sets the deceleration time for maximum frequency to zero for ramp pair 2. See 2203 DECELER TIME 1.</p>
2207	<p>RAMP SHAPE 2</p> <p>Selects the shape of the acceleration/deceleration ramp for ramp pair 2. See 2204 RAMP SHAPE 1.</p>
2208	<p>EMERG DEC TIME</p> <p>Sets the deceleration time for maximum frequency to zero for an emergency.</p> <ul style="list-style-type: none"> See parameter 2109 EMERG STOP SEL. Ramp is linear.

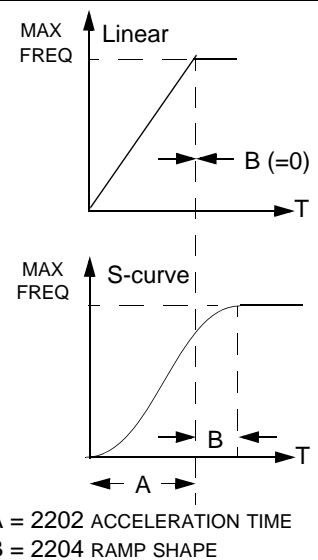

Code	Description
2209	<p>RAMP INPUT ZERO</p> <p>Defines control for forcing the ramp input to zero.</p> <p>0 = NOT SEL</p> <p>1 = DI1 – Defines digital input DI1 as the control for forcing the ramp input to zero.</p> <ul style="list-style-type: none"> • Activating the digital input forces ramp input to zero. Ramp output will ramp to zero according to the currently used ramp time, after which it will stay at zero. • De-activating the digital input: ramp resumes normal operation. <p>2...6 = DI2...DI6 – Defines digital input DI2...DI6 as the control for forcing the ramp input to zero.</p> <ul style="list-style-type: none"> • See DI1 above. <p>7 = COMM – Defines bit 10 of the Command Word 1 as the control for ramp pair selection.</p> <ul style="list-style-type: none"> • The Command Word is parameter 0301, which is supplied through fieldbus communication. <p>-1 = DI1(INV) – Defines an inverted digital input DI1 as the control for forcing the ramp input to zero.</p> <ul style="list-style-type: none"> • De-activating the digital input forces ramp input to zero. • Activating the digital input: ramp resumes normal operation. <p>-2...-6 = DI2(INV)...DI6(INV) – Defines an inverted digital input DI2...DI6 as the control for forcing the ramp function generator input to zero.</p> <ul style="list-style-type: none"> • See DI1(INV) above.

Group 25: Critical Speeds

This group defines up to three critical speeds or ranges of speeds that are to be avoided due, for example, to mechanical resonance problems at certain speeds.

Code	Description
2501	<p>CRIT SPEED SEL</p> <p>Sets the critical speeds function on or off. The critical speed function avoids specific speed ranges.</p> <p>0 = OFF – Disables the critical speeds function. 1 = ON – Enables the critical speeds function.</p> <p>Example: To avoid speeds at which a fan system vibrates badly:</p> <ul style="list-style-type: none"> • Determine problem speed ranges. Assume they are found to be: 18...23 Hz and 46...52 Hz. • Set 2501 CRIT SPEED SEL = 1. • Set 2502 CRIT SPEED 1 LO = 18 Hz. • Set 2503 CRIT SPEED 1 HI = 23 Hz. • Set 2504 CRIT SPEED 2 LO = 46 Hz. • Set 2505 CRIT SPEED 2 HI = 52 Hz.
2502	<p>CRIT SPEED 1 LO</p> <p>Sets the minimum limit for critical speed range 1.</p> <ul style="list-style-type: none"> • The value must be less than or equal to 2503 CRIT SPEED 1 HI. • Units are Hz.
2503	<p>CRIT SPEED 1 HI</p> <p>Sets the maximum limit for critical speed range 1.</p> <ul style="list-style-type: none"> • The value must be greater than or equal to 2502 CRIT SPEED 1 LO. • Units are Hz.
2504	<p>CRIT SPEED 2 LO</p> <p>Sets the minimum limit for critical speed range 2.</p> <p>See parameter 2502.</p>
2505	<p>CRIT SPEED 2 HI</p> <p>Sets the maximum limit for critical speed range 2.</p> <p>See parameter 2503.</p>
2506	<p>CRIT SPEED 3 LO</p> <p>Sets the minimum limit for critical speed range 3.</p> <p>See parameter 2502.</p>
2507	<p>CRIT SPEED 3 HI</p> <p>Sets the maximum limit for critical speed range 3.</p> <p>See parameter 2503.</p>

Group 26: Motor Control

This group defines variables used for motor control.

Code	Description																		
2601	<p>FLUX OPTIMIZATION</p> <p>Changes the magnitude of the flux depending on the actual load. Flux Optimization can reduce the total energy consumption and noise, and it should be enabled for drives that usually operate below nominal load.</p> <p>0 = OFF – Disables the feature. 1 = ON – Enables the feature.</p>																		
2602	<p>FLUX BRAKING</p> <p>Provides faster deceleration by raising the level of magnetization in the motor when needed, instead of limiting the deceleration ramp. By increasing the flux in the motor, the energy of the mechanical system is changed to thermal energy in the motor.</p> <p>0 = OFF – Disables the feature. 1 = ON – Enables the feature.</p> <div style="display: flex; justify-content: space-between;"> <div style="width: 45%;"> <p>Braking Torque (%)</p> </div> <div style="width: 45%;"> <p>Rated Motor Power</p> <ul style="list-style-type: none"> ① 2.2 kW ② 15 kW ③ 37 kW ④ 75 kW ⑤ 250 kW </div> </div>																		
2603	<p>IR COMP VOLT</p> <p>Sets the IR compensation voltage used for 0 Hz.</p> <ul style="list-style-type: none"> Keep IR compensation as low as possible to prevent overheating. Typical IR compensation values are: <table border="1" style="margin-left: 20px;"> <thead> <tr> <th colspan="6">380...480 V drives</th> </tr> <tr> <th>P_N (kW)</th> <td>3</td> <td>7.5</td> <td>15</td> <td>37</td> <td>132</td> </tr> <tr> <th>IR comp (V)</th> <td>18</td> <td>15</td> <td>12</td> <td>8</td> <td>3</td> </tr> </thead></table>	380...480 V drives						P _N (kW)	3	7.5	15	37	132	IR comp (V)	18	15	12	8	3
380...480 V drives																			
P _N (kW)	3	7.5	15	37	132														
IR comp (V)	18	15	12	8	3														
2604	<p>IR COMP FREQ</p> <p>Sets the frequency at which IR compensation is 0 V (in % of motor frequency).</p> <div style="display: flex; justify-content: space-between;"> <div style="width: 45%;"> <p>IR Compensation</p> <ul style="list-style-type: none"> When enabled, IR Compensation provides an extra voltage boost to the motor at low speeds. Use IR Compensation, for example, in applications that require a high breakaway torque. </div> <div style="width: 45%;"> <p>A = IR Compensated B = No compensation</p> </div> </div>																		

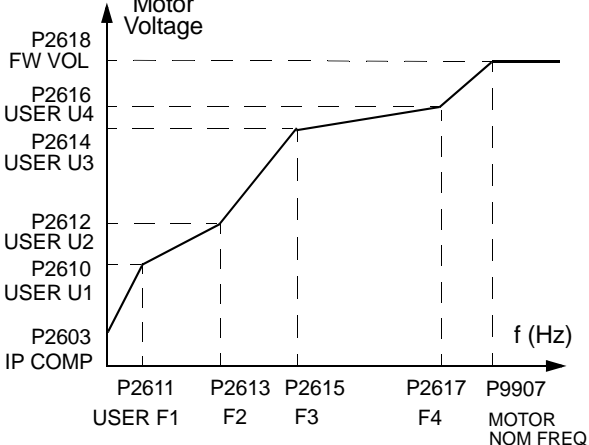
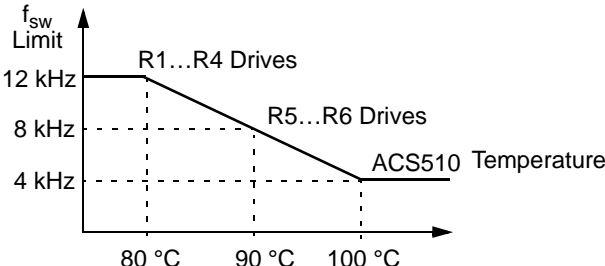
Code	Description
2605	<p>U/F RATIO Selects the form for the U/f (voltage to frequency) ratio below field weakening point. 1 = LINEAR – Preferred for constant torque applications. 2 = SQUARED– Preferred for centrifugal pump and fan applications. (Square is more silent for most operating frequencies.) 3 = FREELY DEFINED - Freely defined by parameter 2610 ... 2618. See figure.</p> 
2606	<p>SWITCHING FREQ Sets the switching frequency for the drive. Also see parameter 2607 SWITCH FREQ CTRL and "Switching Frequency Derating" on page 212.</p> <ul style="list-style-type: none"> • Higher switching frequencies mean less noise. • The 1, 4 and 8 kHz switching frequencies are available for all types, except for ACS510-01-246A-4 and ACS510-01-290A-4 (only 1 and 4 kHz are available). • The 12 kHz switching frequency is available only on frame sizes R1...R4, except for R4 types ACS510-01-088A-4.
2607	<p>SWITCH FREQ CTRL The switching frequency may be reduced if the ACS510 internal temperature rises above a limit. See Figure. This function allows the highest possible switching frequency to be used based on operating conditions. Higher switching frequency results in lower acoustic noise. 0 = OFF – The function is disabled. 1 = ON – The switching frequency is limited according to the figure.</p> 
2608	<p>SLIP COMP RATIO Sets gain for slip compensation (in %). A squirrel-cage motor slips under load. Increasing the frequency as the motor torque increases compensates for the slip. 0 – No slip compensation. 1...200 – Increasing slip compensation. 100% means full slip compensation.</p>
2609	<p>NOISE SMOOTHING This parameter introduces a random component to the switching frequency. Noise smoothing distributes the acoustic motor noise over a range of frequencies instead of a single tonal frequency resulting in lower peak noise intensity. The random component has an average of 0 Hz and is added to the switching frequency set by parameter 2606 SWITCHING FREQ. This parameter has no effect if parameter 2606 = 12 kHz. 0 = DISABLE 1 = ENABLE</p>
2610	<p>USER U1 This parameter define the output voltage reference (in Volts) at P2611 USER F1. Please see parameter 2605.</p>

Code	Description
2611	USER F1 Frequency(in Hz), at which output voltage reference is P2610 USER U1. Please see parmeter 2605.
2612	USER U2 This parameter define the output voltage reference (in Volts) at P2613 USER F2. Please see parmeter 2605.
2613	USER F2 Frequency(in Hz), at which output voltage reference is P2612 USER U2. Please see parmeter 2605.
2614	USER U3 This parameter define the output voltage reference (in Volts) at P2615 USER F3. Please see parmeter 2605.
2615	USER F3 Frequency(in Hz), at which output voltage reference is P2614 USER U3. Please see parmeter 2605.
2616	USER U4 This parameter define the output voltage reference (in Volts) at P2617 USER F4. Please see parmeter 2605.
2617	USER F4 Frequency(in Hz), at which output voltage reference is P2616 USER U4. Please see parmeter 2605.
2618	FW VOLTAGE Maximum output voltage of drive when the output frequency is controlled to level defined by parameter P9907 MOTOR NOM FREQ. Please see parmeter 2605. NOTE! <ul style="list-style-type: none"> The actual output voltage reference is the lower value of the values of parameters P9905 MOTOR NOM VOLT and P2618 FW VOLTAGE. Requirements for parameters setting: $P2618 \geq P2616 \geq P2614 \geq P2612 \geq P2610$ and $P9907 \geq P2617 \geq P2615 \geq P2613 \geq P2611$. If this not true, FAULT 1015 (PAR USER DEFINED U/F) is generated (only when P2605 u/f RATIO = 3).
2619	DC STABILIZER Enables or disables the DC voltage stabilizer. The DC stabilizer is used in scalar control mode to prevent possible voltage oscillations in the drive DC bus caused by motor load or weak supply network. In case of voltage variation the drive tunes the frequency reference to stabilize the DC bus voltage and therefore the load torque oscillation. 0 = DISABLE – Disables DC stabilizer. 1 = ENABLE – Enables DC stabilizer.

Group 30: Fault Functions

This group defines situations that the drive should recognize as potential faults and defines how the drive should respond if the fault is detected.

Code	Description
3001	<p>AI<MIN FUNCTION</p> <p>Defines the drive response if the analog input (AI) signal drops below the fault limits and AI is used in reference chain. 3021 AI1 FAULT LIMIT and 3022 AI2 FAULT LIMIT set the fault limits 0 = NOT SEL – No response. 1 = FAULT – Displays a fault (7, AI1 LOSS or 8, AI2 LOSS) and the drive coasts to stop. 2 = CONST SP 7 – Displays an alarm (2006, AI1 LOSS or 2007, AI2 LOSS) and sets speed using 1208 CONST SPEED 7. 3 = LAST SPEED – Displays an alarm (2006, AI1 LOSS or 2007, AI2 LOSS) and sets speed using the last operating level. This value is the average speed over the last 10 seconds. Warning! If you select CONST SP7 or LAST SPEED, make sure that continued operation is safe when the analog input signal is lost.</p>
3002	<p>PANEL COMM ERR</p> <p>Defines the drive response to a control panel communication error. 1 = FAULT – Displays a fault (10, PANEL LOSS) and the drive coasts to stop. 2 = CONST SP 7 – Displays an alarm (2008, PANEL LOSS) and sets speed using 1208 CONST SPEED 7. 3 = LAST SPEED – Displays an alarm (2008, PANEL LOSS) and sets speed using the last operating level. This value is the average speed over the last 10 seconds. Warning! If you select CONST SP7 or LAST SPEED, make sure that continued operation is safe when the control panel communication is lost.</p>
3003	<p>EXTERNAL FAULT 1</p> <p>Defines the External Fault 1 signal input and the drive response to an external fault. 0 = NOT SEL – External fault signal is not used. 1 = DI1 – Defines digital input DI1 as the external fault input. • Activating the digital input indicates a fault. The drive displays a fault (14, EXT FAULT 1) and the drive coasts to stop. 2...6 = DI2...DI6 – Defines digital input DI2...DI6 as the external fault input. • See DI1 above. -1 = DI1(INV) – Defines an inverted digital input DI1 as the external fault input. • De-activating the digital input indicates a fault. The drive displays a fault (14, EXT FAULT 1) and the drive coasts to stop. -2...-6 = DI2(INV)...DI6(INV) – Defines an inverted digital input DI2...DI6 as the external fault input. • See DI1(INV) above.</p>
3004	<p>EXTERNAL FAULT 2</p> <p>Defines the External Fault 2 signal input and the drive response to an external fault. • See parameter 3003 above.</p>
3005	<p>MOT THERM PROT</p> <p>Defines the drive response to motor overheating. 0 = NOT SEL – No response and/or motor thermal protection not set up. 1 = FAULT – When the calculated motor temperature exceeds 90 C, displays an alarm (2010, MOTOR TEMP). When the calculated motor temperature exceeds 110 C, displays a fault (9, MOT OVERTEMP) and the drive coasts to stop. 2 = ALARM – When the calculated motor temperature exceeds 90 C, displays an alarm (2010, MOTOR TEMP).</p>
3006	<p>MOT THERM TIME</p> <p>Sets the motor thermal time constant for the motor temperature model.</p> <ul style="list-style-type: none"> This is the time required for the motor to reach 63% of the final temperature with steady load. For thermal protection according to UL requirements for NEMA class motors, use the rule of thumb: MOTOR THERM TIME equals 35 times t_6, where t_6 (in seconds) is specified by the motor manufacturer as the time that the motor can safely operate at six times its rated current. The thermal time for a Class 10 trip curve is 350 s, for a Class 20 trip curve 700 s, and for a Class 30 trip curve 1050 s. <div style="text-align: right;"> <p>The graph consists of two vertically aligned plots sharing a common horizontal time axis labeled 't'. The top plot shows 'Motor load' as a rectangular pulse that starts at a certain time, remains constant at a high level, and then returns to zero. The bottom plot shows 'Temp. Rise' as a curve that starts at zero, rises asymptotically towards a steady-state value of 100%. A horizontal dashed line at 63% intersects the curve, and a vertical dashed line drops from that point to the time axis, marking the time constant. The label 'P 3006' is placed below the time axis at this point. The curve continues to rise to 100% and then decays back to zero.</p> </div>

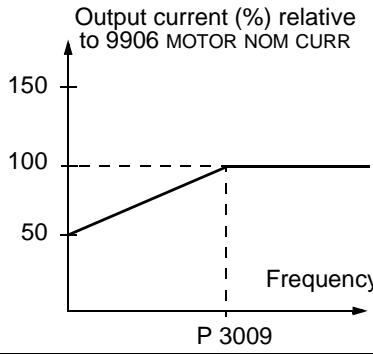
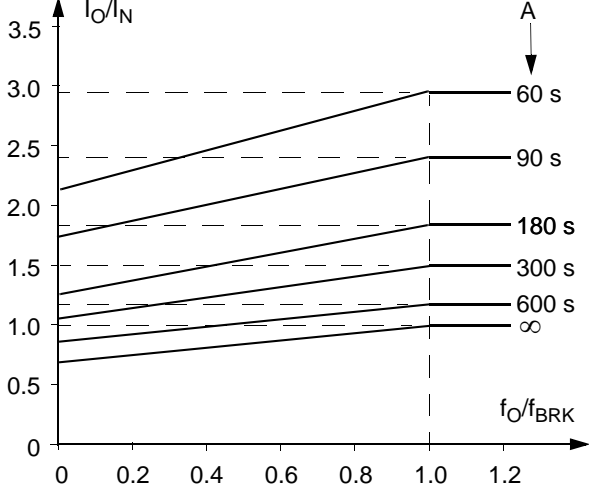
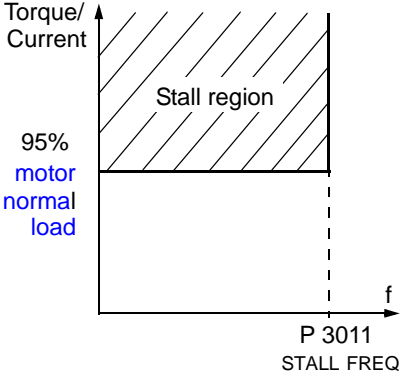
Code	Description	
3007	MOT LOAD CURVE Sets the maximum allowable operating load of the motor. <ul style="list-style-type: none"> When set to 100%, the maximum allowable load is equal to the value of parameter 9906 MOTOR NOM CURR. Adjust the load curve level if the ambient temperature differs from nominal. 	
3008	ZERO SPEED LOAD Sets the maximum allowable current at zero speed. Value is relative to 9906 MOTOR NOM CURR.	
3009	BREAK POINT FREQ Sets the break point frequency for the motor load curve.	
Example: Thermal protection trip times when parameters 3006 MOT THERM TIME, 3007 MOT LOAD CURVE and 3008 ZERO SPEED LOAD have default values.		
 <p style="margin-left: 400px;"> I_O = Output current I_N = Nominal motor current f_O = Output frequency f_{BRK} = Break point frequency A = Trip time </p>		
3010	STALL FUNCTION This parameter defines the operation of the Stall function. This protection is active if the drive operates in the stall region (see figure) for the time defined by 3012 STALL TIME. <p>0 = NOT SEL – Stall protection is not used.</p> <p>1 = FAULT – When the drive operates in the stall region for the time set by 3012 STALL TIME:</p> <ul style="list-style-type: none"> The drive coasts to stop. A fault indication is displayed. <p>2 = ALARM – When the drive operates in the stall region for the time set by 3012 STALL TIME:</p> <ul style="list-style-type: none"> An alarm indication is displayed. The alarm disappears when the drive is out of the stall region for half the time set by parameter 3012 STALL TIME. 	
3011	STALL FREQUENCY This parameter sets the frequency value for the Stall function. Refer to Figure.	
3012	STALL TIME This parameter sets the time value for the Stall function.	
3017	EARTH FAULT Defines the drive response if the drive detects a ground fault in the motor or motor cables. The drive monitors for ground faults while the drive is running, and while the drive is not running. Also see parameter 3023 WIRING FAULT. <p>0 = DISABLE – No drive response to ground faults.</p> <p>1 = ENABLE – Ground faults display fault 16 (EARTH FAULT), and (if running) the drive coasts to stop.</p>	

Code	Description
3018	<p>COMM FAULT FUNC</p> <p>Defines the drive response if the fieldbus communication is lost.</p> <p>0 = NOT SEL – No response.</p> <p>1 = FAULT – Displays a fault (28, SERIAL 1 ERR) and the drive coasts to stop.</p> <p>2 = CONST SP 7 – Displays an alarm (2005, I/O COMM) and sets speed using 1208 CONST SPEED 7. This “alarm speed” remains active until the fieldbus writes a new reference value.</p> <p>3 = LAST SPEED – Displays an alarm (2005, I/O COMM) and sets speed using the last operating level. This value is the average speed over the last 10 seconds. This “alarm speed” remains active until the fieldbus writes a new reference value.</p> <p>Caution: If you select CONST SP 7, or LAST SPEED, make sure that continued operation is safe when fieldbus communication is lost.</p>
3019	<p>COMM FAULT TIME</p> <p>Sets the communication fault time used with 3018 COMM FAULT FUNC.</p> <p>Brief interruptions in the fieldbus communication are not treated as faults if they are less than the COMM FAULT TIME value.</p>
3021	<p>AI1 FAULT LIMIT</p> <p>Sets a fault level for analog input 1. See 3001 AI<MIN FUNCTION.</p>
3022	<p>AI2 FAULT LIMIT</p> <p>Sets a fault level for analog input 2. See 3001 AI<MIN FUNCTION.</p>
3023	<p>WIRING FAULT</p> <p>Defines the drive response to cross wiring faults and to ground faults detected when the drive is NOT running. When the drive is not running it monitors for:</p> <ul style="list-style-type: none"> • Improper connections of input power to the drive output (the drive can display fault 35, OUTPUT WIRING if improper connections are detected). • Ground faults (the drive can display fault 16, EARTH FAULT if a ground fault is detected). Also, see parameter 3017 EARTH FAULT. <p>0 = DISABLE – No drive response to either of the above monitoring results.</p> <p>1 = ENABLE – The drive displays faults when this monitoring detects problems.</p>
3024	<p>CB TEMP FAULT</p> <p>Defines the drive response to control board overheating. Not for drives with an OMIO control board.</p> <p>0 = DISABLE – No response</p> <p>1 = ENABLE – Displays faults 37 (CB OVERTEMP) and the drive coasts to stop.</p>

Group 31: Automatic Reset

This group defines conditions for automatic resets. An automatic reset occurs after a particular fault is detected. The drive holds for a set delay time, then automatically restarts. You can limit the number of resets in a specified time period and set up automatic resets for a variety of faults.

Code	Description
3101	<p>NUMBER OF TRIALS</p> <p>Sets the number of allowed automatic resets within a trial period defined by 3102 TRIAL TIME.</p> <ul style="list-style-type: none"> • If the number of automatic resets exceeds this limit (within the trial time), the drive prevents additional automatic resets and remains stopped. • Starting then requires a successful reset performed from the control panel or from a source selected by 1604 FAULT RESET SEL.
3102	<p>TRIAL TIME</p> <p>Sets the time period used for counting and limiting the number of resets.</p> <ul style="list-style-type: none"> • See 3101 NUMBER OF TRIALS.
3103	<p>DELAY TIME</p> <p>Sets the delay time between a fault detection and attempted drive restart.</p> <p>If DELAY TIME = zero, the drive resets immediately.</p>
3104	<p>AR OVERCURRENT</p> <p>Sets the automatic reset for the overcurrent function on or off.</p> <p>0 = DISABLE – Disables automatic reset. 1 = ENABLE – Enables automatic reset.</p> <ul style="list-style-type: none"> • Automatically resets the fault (OVERCURRENT) after the delay set by 3103 DELAY TIME, and the drive resumes normal operation.
3105	<p>AR OVERVOLTAGE</p> <p>Sets the automatic reset for the overvoltage function on or off.</p> <p>0 = DISABLE – Disables automatic reset. 1 = ENABLE – Enables automatic reset.</p> <ul style="list-style-type: none"> • Automatically resets the fault (DC OVERVOLT) after the delay set by 3103 DELAY TIME, and the drive resumes normal operation.
3106	<p>AR UNDERVOLTAGE</p> <p>Sets the automatic reset for the undervoltage function on or off.</p> <p>0 = DISABLE – Disables automatic reset. 1 = ENABLE – Enables automatic reset.</p> <ul style="list-style-type: none"> • Automatically resets the fault (DC UNDERVOLT) after the delay set by 3103 DELAY TIME, and the drive resumes normal operation.
3107	<p>AR AI<MIN</p> <p>Sets the automatic reset for the analog input less than minimum value function on or off.</p> <p>0 = DISABLE – Disables automatic reset. 1 = ENABLE – Enables automatic reset.</p> <ul style="list-style-type: none"> • Automatically resets the fault (AI<MIN) after the delay set by 3103 DELAY TIME, and the drive resumes normal operation. <p>Warning! When the analog input signal is restored, the drive may restart, even after a long stop. Make sure that automatic, long delayed starts will not cause physical injury and/or damage equipment.</p>
3108	<p>AR EXTERNAL FLT</p> <p>Sets the automatic reset for external faults function on or off.</p> <p>0 = DISABLE – Disables automatic reset. 1 = ENABLE – Enables automatic reset.</p> <ul style="list-style-type: none"> • Automatically resets the fault (EXT FAULT 1 or EXT FAULT 2) after the delay set by 3103 DELAY TIME, and the drive resumes normal operation.

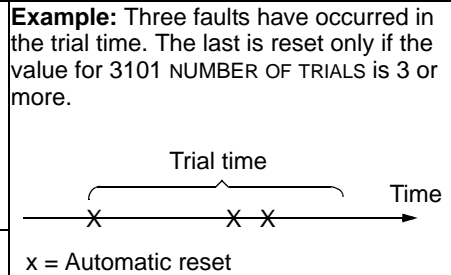

Group 32: Supervision

This group defines supervision for up to three signals from Group 01, Operating Data. Supervision monitors a specified parameter and energizes a relay output if the parameter passes a defined limit. Use Group 14, Relay Outputs, to define the relay and whether the relay activates when the signal is too low or too high.

Code	Description
3201	<p>SUPERV 1 PARAM</p> <p>Selects the first supervised parameter.</p> <ul style="list-style-type: none"> • Must be a parameter number from Group 01 Operating Data. • 100 = NOT SELECTED. • 101...159 – Selects parameter 0101...0159. • If the supervised parameter passes a limit, a relay output is energized. • The supervision limits are defined in this group. • The relay outputs are defined in Group 14 Relay Outputs (definition also specifies which supervision limit is monitored). <p>LO ≤ HI</p> <p>Operating data supervision using relay outputs, when $LO \leq HI$.</p> <ul style="list-style-type: none"> • Case A = Parameter 1401 RELAY OUTPUT 1 (or 1402 RELAY OUTPUT 2, etc.) value is SUPRV1 OVER or SUPRV 2 OVER. Use for monitoring when/if the supervised signal exceeds a given limit. The relay remains active until the supervised value drops below the low limit. • Case B = Parameter 1401 RELAY OUTPUT 1 (or 1402 RELAY OUTPUT 2, etc.) value is SUPRV 1 UNDER or SUPRV 2 UNDER. Use for monitoring when/if the supervised signal falls below a given limit. The relay remains active until the supervised value rises above the high limit. <p>LO > HI</p> <p>Operating data supervision using relay outputs, when $LO > HI$. The lowest limit (HI 3203) is active initially, and remains active until the supervised parameter goes above the highest limit (LO 3202), making that limit the active limit. That limit remains active until the supervised parameter goes below the lowest limit (HI 3203), making that limit active.</p> <ul style="list-style-type: none"> • Case A = Parameter 1401 RELAY OUTPUT 1 (or 1402 RELAY OUTPUT 2, etc.) value is SUPRV1 OVER or SUPRV2 OVER. Initially the relay is de-energized. It is energized whenever the supervised parameter goes above the active limit. • Case B = Parameter 1402 RELAY OUTPUT 1 (or 1402 RELAY OUTPUT 2, etc.) value is SUPRV1 UNDER or SUPRV2 UNDER. Initially the relay is energized. It is de-energized whenever the supervised parameter goes below the active limit.
3202	<p>SUPERV 1 LIM LO</p> <p>Sets the low limit for the first supervised parameter. See 3201 SUPERV 1 PARAM above.</p>
3203	<p>SUPERV 1 LIM HI</p> <p>Sets the high limit for the first supervised parameter. See 3201 SUPERV 1 PARAM above.</p>
3204	<p>SUPERV 2 PARAM</p> <p>Selects the second supervised parameter. See 3201 SUPERV 1 PARAM above.</p>
3205	<p>SUPERV 2 LIM LO</p> <p>Sets the low limit for the second supervised parameter. See 3204 SUPERV 2 PARAM above.</p>
3206	<p>SUPERV 2 LIM HI</p> <p>Sets the high limit for the second supervised parameter. See 3204 SUPERV 2 PARAM above.</p>

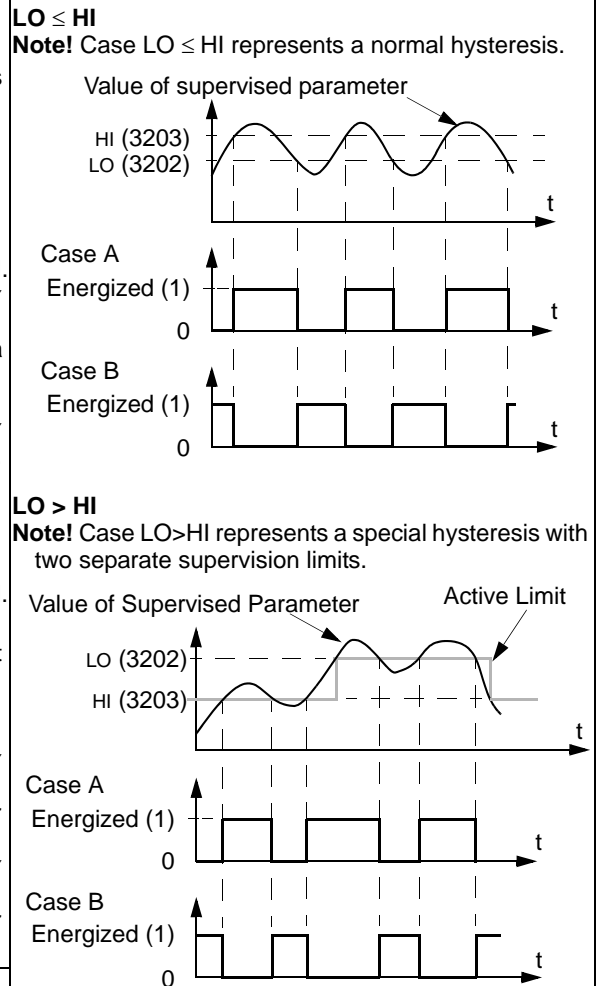

Code	Description
3207	SUPERV 3 PARAM Selects the third supervised parameter. See 3201 SUPERV 1 PARAM above.
3208	SUPERV 3 LIM LO Sets the low limit for the third supervised parameter. See 3207 SUPERV 3 PARAM above.
3209	SUPERV 3 LIM HI Sets the high limit for the third supervised parameter. See 3207 SUPERV 3 PARAM above.

Group 33: Information

This group provides access to information about the drive's current programs: versions and test date.

Code	Description
3301	FIRMWARE Contains the version of the drive's firmware.
3302	LOADING PACKAGE Contains the version of the loading package.
3303	TEST DATE Contains the test date (yy.ww).
3304	DRIVE RATING Indicates the drive's current and voltage rating. The format is XXXY, where: <ul style="list-style-type: none"> • XXX = The nominal current rating of the drive in amps. If present, an "A" indicates a decimal point in the rating for the current. For example XXX = 9A4, indicates a nominal current rating of 9.4Amps. • Y = The voltage rating of the drive, where Y = : <ul style="list-style-type: none"> • 4 indicates a 380...480 Volt rating.
3305	PARAMETER TABLE Contains the parameter table version of the drive's firmware.

Group 34: Panel Display Process Variables

This group defines the content for control panel display (middle area), when the control panel is in the Output mode.

Code	Description																																																																																				
3401	<p>SIGNAL1 PARAM</p> <p>Selects the first parameter (by number) displayed on the control panel.</p> <ul style="list-style-type: none"> Definitions in this group define display content when the control panel is in the control mode. Any Group 01 parameter number can be selected. Using the following parameters, the display value can be scaled, converted to convenient units, and/or displayed as a bar graph. The figure identifies selections made by parameters in this group. <p>100 = not selected – First parameter not displayed. 101...159 = Displays parameter 0101...0159. If parameter does not exist, the display shows "n.a."</p>																																																																																				
3402	<p>SIGNAL1 MIN</p> <p>Defines the minimum expected value for the first display parameter. Use parameters 3402, 3403, 3406, and 3407, for example to convert a Group 01 parameter, such as 0102 SPEED (in rpm) to the speed of a conveyor driven by the motor (in ft/min). For such a conversion, the source values in the figure are the min. and max. motor speed, and the display values are the corresponding min. and max. conveyor speed. Use parameter 3405 to select the proper units for the display. Note! Selecting units does not convert values. Parameter is not effective if parameter 3404 OUTPUT1 DSP FORM = 9 (DIRECT).</p>																																																																																				
3403	<p>SIGNAL1 MAX</p> <p>Defines the maximum expected value for the first display parameter. Note: Parameter is not effective if parameter 3404 OUTPUT1 DSP FORM = 9 (DIRECT).</p>																																																																																				
3404	<p>OUTPUT1 DSP FORM</p> <p>Defines the decimal point location for the first display parameter. 0...7 – Defines the decimal point location.</p> <ul style="list-style-type: none"> Enter the number of digits desired to the right of the decimal point. See the table for an example using pi (3.14159). <p>8 = BAR METER – Specifies a bar meter display. 9 = DIRECT – Decimal point location and units of measure are identical to the source signal. See Group 01 parameter listing in "Complete Parameter List" for resolution (which indicates the decimal point location) and the units of measure.</p> <table border="1"> <thead> <tr> <th>3404 Value</th> <th>Display</th> <th>Range</th> </tr> </thead> <tbody> <tr> <td>0</td> <td>± 3</td> <td rowspan="4">-32768...+32767 (Signed)</td> </tr> <tr> <td>1</td> <td>± 3.1</td> </tr> <tr> <td>2</td> <td>± 3.14</td> </tr> <tr> <td>3</td> <td>± 3.142</td> </tr> <tr> <td>4</td> <td>3</td> <td rowspan="4">0...65535 (Unsigned)</td> </tr> <tr> <td>5</td> <td>3.1</td> </tr> <tr> <td>6</td> <td>3.14</td> </tr> <tr> <td>7</td> <td>3.142</td> </tr> </tbody> </table>	3404 Value	Display	Range	0	± 3	-32768...+32767 (Signed)	1	± 3.1	2	± 3.14	3	± 3.142	4	3	0...65535 (Unsigned)	5	3.1	6	3.14	7	3.142																																																															
3404 Value	Display	Range																																																																																			
0	± 3	-32768...+32767 (Signed)																																																																																			
1	± 3.1																																																																																				
2	± 3.14																																																																																				
3	± 3.142																																																																																				
4	3	0...65535 (Unsigned)																																																																																			
5	3.1																																																																																				
6	3.14																																																																																				
7	3.142																																																																																				
3405	<p>OUTPUT1 UNIT</p> <p>Selects the units used with the first display parameter. Parameter is not effective if parameter 3404 OUTPUT1 DSP FORM = 9 (DIRECT).</p> <table border="0"> <tr> <td>0 = NO UNIT</td> <td>9 = °C</td> <td>18 = MWh</td> <td>27 = ft</td> <td>36 = l/s</td> <td>45 = Pa</td> <td>54 = lb/m</td> <td>63 = Mrev</td> </tr> <tr> <td>1 = A</td> <td>10 = lb ft</td> <td>19 = m/s</td> <td>28 = MGD</td> <td>37 = l/min</td> <td>46 = GPS</td> <td>55 = lb/h</td> <td>64 = d</td> </tr> <tr> <td>2 = V</td> <td>11 = mA</td> <td>20 = m³/h</td> <td>29 = inHg</td> <td>38 = l/h</td> <td>47 = gal/s</td> <td>56 = FPS</td> <td>65 = inWC</td> </tr> <tr> <td>3 = Hz</td> <td>12 = mV</td> <td>21 = dm³/s</td> <td>30 = FPM</td> <td>39 = m³/s</td> <td>48 = gal/m</td> <td>57 = ft/s</td> <td>66 = m/min</td> </tr> <tr> <td>4 = %</td> <td>13 = kW</td> <td>22 = bar</td> <td>31 = kb/s</td> <td>40 = m³/m</td> <td>49 = gal/h</td> <td>58 = inH₂O</td> <td>67 = Nm</td> </tr> <tr> <td>5 = s</td> <td>14 = W</td> <td>23 = kPa</td> <td>32 = kHz</td> <td>41 = kg/s</td> <td>50 = ft³/s</td> <td>59 = in wg</td> <td></td> </tr> <tr> <td>6 = h</td> <td>15 = kWh</td> <td>24 = GPM</td> <td>33 = Ohm</td> <td>42 = kg/m</td> <td>51 = ft³/m</td> <td>60 = ft wg</td> <td></td> </tr> <tr> <td>7 = rpm</td> <td>16 = °F</td> <td>25 = PSI</td> <td>34 = ppm</td> <td>43 = kg/h</td> <td>52 = ft³/h</td> <td>61 = lbsi</td> <td></td> </tr> <tr> <td>8 = kh</td> <td>17 = hp</td> <td>26 = CFM</td> <td>35 = pps</td> <td>44 = mbar</td> <td>53 = lb/s</td> <td>62 = ms</td> <td></td> </tr> </table> <p>The following units are useful for the bar display.</p> <table border="0"> <tr> <td>117 = %ref</td> <td>119 = %dev</td> <td>121 = % SP</td> <td>123 = Iout</td> <td>125 = Fout</td> <td>127 = Vdc</td> </tr> <tr> <td>118 = %act</td> <td>120 = % LD</td> <td>122 = %FBK</td> <td>124 = Vout</td> <td>126 = Tout</td> <td></td> </tr> </table>	0 = NO UNIT	9 = °C	18 = MWh	27 = ft	36 = l/s	45 = Pa	54 = lb/m	63 = Mrev	1 = A	10 = lb ft	19 = m/s	28 = MGD	37 = l/min	46 = GPS	55 = lb/h	64 = d	2 = V	11 = mA	20 = m³/h	29 = inHg	38 = l/h	47 = gal/s	56 = FPS	65 = inWC	3 = Hz	12 = mV	21 = dm³/s	30 = FPM	39 = m³/s	48 = gal/m	57 = ft/s	66 = m/min	4 = %	13 = kW	22 = bar	31 = kb/s	40 = m³/m	49 = gal/h	58 = inH₂O	67 = Nm	5 = s	14 = W	23 = kPa	32 = kHz	41 = kg/s	50 = ft³/s	59 = in wg		6 = h	15 = kWh	24 = GPM	33 = Ohm	42 = kg/m	51 = ft³/m	60 = ft wg		7 = rpm	16 = °F	25 = PSI	34 = ppm	43 = kg/h	52 = ft³/h	61 = lbsi		8 = kh	17 = hp	26 = CFM	35 = pps	44 = mbar	53 = lb/s	62 = ms		117 = %ref	119 = %dev	121 = % SP	123 = Iout	125 = Fout	127 = Vdc	118 = %act	120 = % LD	122 = %FBK	124 = Vout	126 = Tout	
0 = NO UNIT	9 = °C	18 = MWh	27 = ft	36 = l/s	45 = Pa	54 = lb/m	63 = Mrev																																																																														
1 = A	10 = lb ft	19 = m/s	28 = MGD	37 = l/min	46 = GPS	55 = lb/h	64 = d																																																																														
2 = V	11 = mA	20 = m³/h	29 = inHg	38 = l/h	47 = gal/s	56 = FPS	65 = inWC																																																																														
3 = Hz	12 = mV	21 = dm³/s	30 = FPM	39 = m³/s	48 = gal/m	57 = ft/s	66 = m/min																																																																														
4 = %	13 = kW	22 = bar	31 = kb/s	40 = m³/m	49 = gal/h	58 = inH₂O	67 = Nm																																																																														
5 = s	14 = W	23 = kPa	32 = kHz	41 = kg/s	50 = ft³/s	59 = in wg																																																																															
6 = h	15 = kWh	24 = GPM	33 = Ohm	42 = kg/m	51 = ft³/m	60 = ft wg																																																																															
7 = rpm	16 = °F	25 = PSI	34 = ppm	43 = kg/h	52 = ft³/h	61 = lbsi																																																																															
8 = kh	17 = hp	26 = CFM	35 = pps	44 = mbar	53 = lb/s	62 = ms																																																																															
117 = %ref	119 = %dev	121 = % SP	123 = Iout	125 = Fout	127 = Vdc																																																																																
118 = %act	120 = % LD	122 = %FBK	124 = Vout	126 = Tout																																																																																	

Code	Description
3406	OUTPUT1 MIN Sets the minimum value displayed for the first display parameter. Note: Parameter is not effective if parameter 3404 OUTPUT1 DSP FORM = 9 (DIRECT).
3407	OUTPUT1 MAX Sets the maximum value displayed for the first display parameter. Note: Parameter is not effective if parameter 3404 OUTPUT1 DSP FORM = 9 (DIRECT).
3408	SIGNAL2 PARAM Selects the second parameter (by number) displayed on the control panel. See parameter 3401.
3409	SIGNAL2 MIN Defines the minimum expected value for the second display parameter. See parameter 3402.
3410	SIGNAL2 MAX Defines the maximum expected value for the second display parameter. See parameter 3403.
3411	OUTPUT2 DSP FORM Defines the decimal point location for the second display parameter. See parameter 3404.
3412	OUTPUT2 DSP UNIT Selects the units used with the second display parameter. See parameter 3405.
3413	OUTPUT2 MIN Sets the minimum value displayed for the second display parameter. See parameter 3406.
3414	OUTPUT2 MAX Sets the maximum value displayed for the second display parameter. See parameter 3407.
3415	SIGNAL3 PARAM Selects the third parameter (by number) displayed on the control panel. See parameter 3401.
3416	SIGNAL3 MIN Defines the minimum expected value for the third display parameter. See parameter 3402.
3417	SIGNAL3 MAX Defines the maximum expected value for the third display parameter. See parameter 3403.
3418	OUTPUT3 DSP FORM Defines the decimal point location for the third display parameter. See parameter 3404.
3419	OUTPUT3 DSP UNIT Selects the units used with the third display parameter. See parameter 3405.
3420	OUTPUT3 MIN Sets the minimum value displayed for the third display parameter. See parameter 3406.
3421	OUTPUT3 MAX Sets the maximum value displayed for the third display parameter. See parameter 3407.

Group 35: Motor Temp Meas

This group defines the detection and reporting for a particular potential fault – motor overheating, as detected by a temperature sensor. Typical connections are defined below.

One Sensor

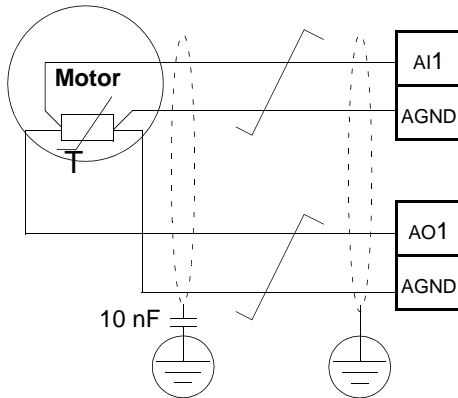

Three Sensors

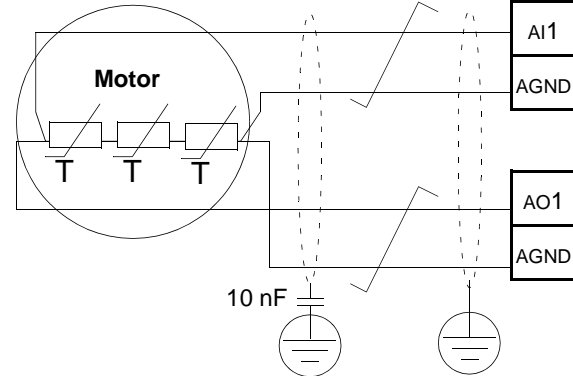

Warning! IEC 60664 requires double or reinforced insulation between live parts and the surface of accessible parts of electrical equipment which are either non-conductive or conductive but not connected to the protective earth.

To fulfil this requirement, connect a thermistor (and other similar components) to the drive's control terminals using any of these alternatives:

- Separate the thermistor from live parts of the motor with double reinforced insulation.
- Protect all circuits connected to the drive's digital and analog inputs. Protect against contact, and insulate from other low voltage circuits with basic insulation (rated for the same voltage level as the drive's main circuit).
- Use an external thermistor relay. The relay insulation must be rated for the same voltage level as the drive's main circuit.

The figure below shows alternate thermistor connections. At the motor end the cable shield should be earthed through a 10 nF capacitor. If this is not possible, leave the shield unconnected.

Thermistor Relay: THERM (0) or (1)

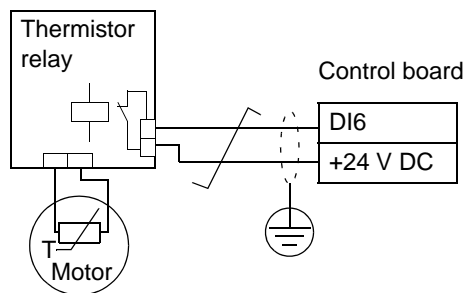

THERM (0)

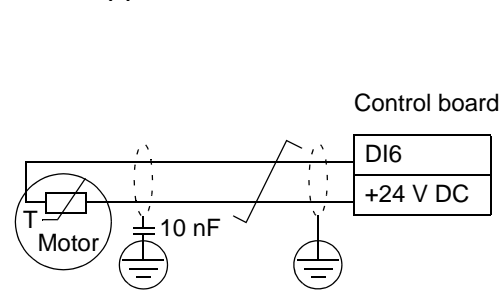

For other faults, or for anticipating motor overheating using a model, see Group 30: Fault Functions.

Code	Description						
3501	<p>SENSOR TYPE Identifies the type of motor temperature sensor used, PT100 (°C) or PTC (ohm) or thermistor. See parameters 1501 and 1507. 0 = NONE 1 = 1 x PT100 – Sensor configuration uses one PT100 sensor. • Analog output AO1 or AO2 feeds constant current through the sensor. • The sensor resistance increases as the motor temperature rises, as does the voltage over the sensor. • The temperature measurement function reads the voltage through analog input AI1 or AI2 and converts it to degrees Celsius. 2 = 2 x PT100 – Sensor configuration uses two PT100 sensors. • Operation is the same as for above 1 x PT100. 3 = 3 x PT100 – Sensor configuration uses three PT100 sensors. • Operation is the same as for above 1 x PT100. 4 = PTC – Sensor configuration uses PTC. • The analog output feeds a constant current through the sensor. • The resistance of the sensor increases sharply as the motor temperature rises over the PTC reference temperature (T_{ref}), as does the voltage over the resistor. The temperature measurement function reads the voltage through analog input AI1 and converts it into ohms. • The figure shows typical PTC sensor resistance values as a function of the motor operating temperature.</p> <table border="1" data-bbox="300 940 737 1033"> <thead> <tr> <th>Temperature</th> <th>Resistance</th> </tr> </thead> <tbody> <tr> <td>Normal</td> <td>< 3 kohm</td> </tr> <tr> <td>Excessive</td> <td>> 28 kohm</td> </tr> </tbody> </table> <p>5 = THERM (0) – Sensor configuration uses a thermistor. • Motor thermal protection is activated through a digital input. Connect either a PTC sensor or a normally closed thermistor relay to a digital input. The drive reads the digital input states as shown in the above table. • When the digital input is '0' the motor is overheated. • See the figures in the introduction to this Group. 6 = THERM (1) – Sensor configuration uses a thermistor. • Motor thermal protection is activated through a digital input. Connect a normally open thermistor relay to a digital input. The drive reads the digital input states as shown in the above table. • When the digital input is '1' the motor is overheated. • See the figures in the introduction to this Group.</p>	Temperature	Resistance	Normal	< 3 kohm	Excessive	> 28 kohm
Temperature	Resistance						
Normal	< 3 kohm						
Excessive	> 28 kohm						
3502	<p>INPUT SELECTION Defines the input used for the temperature sensor. 1 = AI1 – PT100 and PTC. 2 = AI2 – PT100 and PTC. 3...8 = DI1...DI6 – Thermistor</p>						
3503	<p>ALARM LIMIT Defines the alarm limit for motor temperature measurement. At motor temperatures above this limit, the drive displays an alarm (2010, MOTOR OVERTEMP) For thermistors: 0 – de-activated 1 – activated</p>						
3504	<p>FAULT LIMIT Defines the fault limit for motor temperature measurement. At motor temperatures above this limit, the drive displays a fault (9, MOTOR OVERTEMP) and stops the drive. For thermistors: 0 – de-activated 1 – activated</p>						

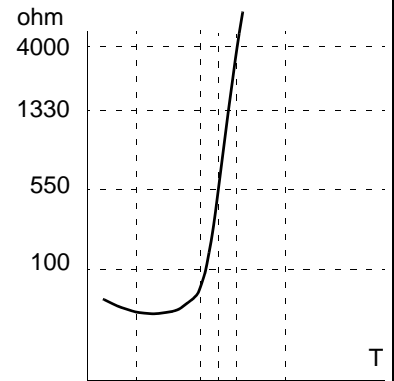

Group 37: User Adjustable Load Curves

This group defines supervision of user adjustable load curves (motor torque as a function of frequency). The curve is defined by five points. -The function replaces deleted underload parameters 3013...3015.

Code	Description
3701	<p>USER LOAD C MODE Supervision mode for the user adjustable load curves. This functionality replaces the former underload supervision in <i>Group 30: Fault Functions</i>. 0 = NOT SEL – Supervision is not active. 1 = UNDERLOAD – Supervision for the torque dropping below the underload curve. 2 = OVERLOAD – Supervision for the torque exceeding the overload curve. 3 = BOTH – Supervision for the torque dropping below the underload curve or exceeding the overload curve.</p>
3702	<p>USER LOAD C FUNC Action wanted during load supervision. 1 = FAULT – A fault is generated when the condition defined by 3701 USER LOAD C MODE has been valid longer than the time set by 3703 USER LOAD C TIME. 2 = ALARM – An alarm is generated when the condition defined by 3701 USER LOAD C MODE has been valid longer than half of the time defined by 3703 USER LOAD C TIME.</p>
3703	<p>USER LOAD C TIME Defines the time limit for generating a fault. Half of this time is used as the limit for generating an alarm.</p>
3704	<p>LOAD FREQ 1 Defines the frequency value of the first curve definition point. Must be smaller than 3707 LOAD FREQ 2.</p>
3705	<p>LOAD TORQ LOW 1 Defines the torque value of the first underload curve definition point. Must be smaller than 3706 LOAD TORQ HIGH 1.</p>
3706	<p>LOAD TORQ HIGE 1 Defines the torque value of the first overload curve definition point.</p>
3707	<p>LOAD FREQ 2 Defines the frequency value of the second curve definition point. Must be smaller than 3710 LOAD FREQ 3.</p>
3708	<p>LOAD TORQ LOW 2 Defines the torque value of the second underload curve definition point. Must be smaller than 3709 LOAD TORQ HIGH 2.</p>
3709	<p>LOAD TORQ HIGE 2 Defines the torque value of the second overload curve definition point.</p>
3710	<p>LOAD FREQ 3 Defines the frequency value of the third load curve definition point.</p>
3711	<p>LOAD TORQ LOW 3 Defines the torque value of the third underload curve definition point. Must be smaller than 3712 LOAD TORQ HIGH 3.</p>
3712	<p>LOAD TORQ HIGE 3 Defines the torque value of the third overload curve definition point.</p>
3713	<p>LOAD FREQ 4 Defines the frequency value of the fourth load curve definition point.</p>
3714	<p>LOAD TORQ LOW 4 Defines the torque value of the fourth underload curve definition point. Must be smaller than 3715 LOAD TORQ HIGH 4.</p>
3715	<p>LOAD TORQ HIGE 4 Defines the torque value of the fourth overload curve definition point.</p>

Code	Description
3716	LOAD FREQ 5 Defines the frequency value of the fifth load curve definition point.
3717	LOAD TORQ LOW 5 Defines the torque value of the fifth underload curve definition point. Must be smaller than 3718 LOAD TORQ HIGH 5.
3718	LOAD TORQ HIGE 5 Defines the torque value of the fifth overload curve definition point.

Group 40: Process PID Set 1

This group defines a set of parameters used with the Process PID (PID1) controller. Typically only parameters in this group are needed.

PID Controller – Basic Set-up

In PID control mode, the drive compares a reference signal (setpoint) to an actual signal (feedback), and automatically adjusts the speed of the drive to match the two signals. The difference between the two signals is the error value.

Typically PID control mode is used, when the speed of a motor needs to be controlled based on pressure, flow or temperature. In most cases – when there is only 1 transducer signal wired to the ACS510 – only parameter group 40 is needed.

The following is a schematic of setpoint/feedback signal flow using parameter group 40.

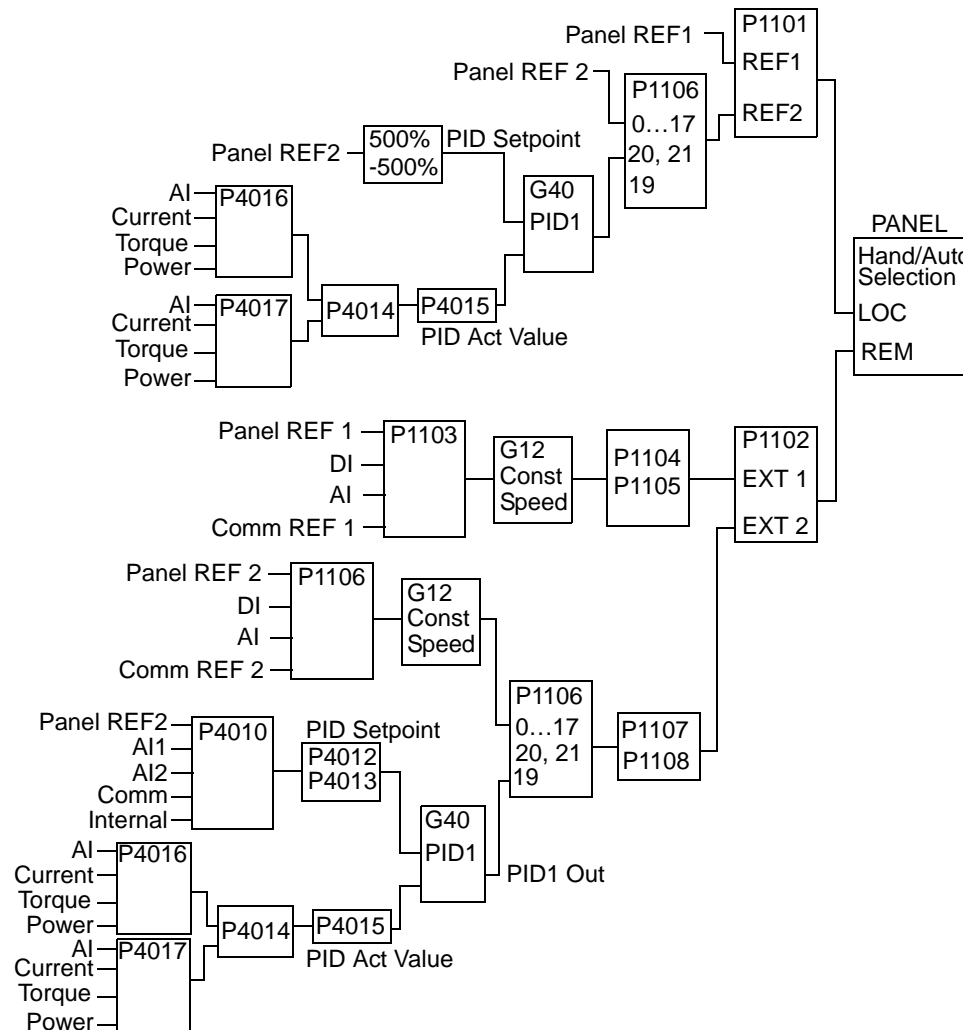

Note! In order to activate and use the PID controller Parameter 1106 must be set to value 19.

PID Controller – Advanced

ACS510 has two separate PID Controllers:

- Process PID (PID1) and
- External PID (PID2)

Process PID (PID1) has 2 separate sets of parameters:

- Process PID (PID1) SET1, defined in Group 40 and
- Process PID (PID1) SET2, defined in Group 41

You can select between the two different sets by using parameter 4027.

Typically two different PID-Controller sets are used when the load of the motor changes considerably from one situation to another.

You can use External PID (PID2), defined in Group 42, in two different ways:

- Instead of using additional PID-controller hardware, you can set outputs of the ACS510 to control a field instrument like a damper or a valve. In this case, set Parameter 4230 to value 0. (0 is the default value.)
- You can use External PID (PID2) to trim or fine-tune the speed of the ACS510.

Code	Description
4001	<p>GAIN</p> <p>Defines the PID Controller's gain.</p> <ul style="list-style-type: none"> • The setting range is 0.1... 100. • At 0.1, the PID Controller output changes one-tenth as much as the error value. • At 100, the PID Controller output changes one hundred times as much as the error value. <p>Use the proportional gain and integration time values to adjust the responsiveness of the system.</p> <ul style="list-style-type: none"> • A low value for proportional gain and a high value for integral time ensures stable operation, but provides sluggish response. <p>If the proportional gain value is too large or the integral time too short, the system can become unstable.</p> <p>Procedure:</p> <ul style="list-style-type: none"> • Initially, set: <ul style="list-style-type: none"> • 4001 GAIN = 0.1. • 4002 INTEGRATION TIME = 20 seconds. • Start the system and see if it reaches the set point quickly while maintaining stable operation. If not, increase GAIN (4001) until the actual signal (or drive speed) oscillates constantly. It may be necessary to start and stop the drive to induce this oscillation. • Reduce GAIN (4001) until the oscillation stops. • Set GAIN (4001) to 0.4 to 0.6 times the above value. • Decrease the INTEGRATION TIME (4002) until the feedback signal (or drive speed) oscillates constantly. It may be necessary to start and stop the drive to induce this oscillation. • Increase INTEGRATION TIME (4002) until the oscillation stops. • Set INTEGRATION TIME (4002) to 1.15 to 1.5 times the above value. • If the feedback signal contains high frequency noise, increase the value of Parameter 1303 FILTER AI1 or 1306 FILTER AI2 until the noise is filtered from the signal.

Code	Description															
4002	<p>INTEGRATION TIME</p> <p>Defines the PID Controller's integration time.</p> <p>Integration time is, by definition, is the time required to increase the output by the error value:</p> <ul style="list-style-type: none"> • Error value is constant and 100%. • Gain = 1. • Integration time of 1 second denotes that a 100% change is achieved in 1 second. <p>0.0 = NOT SEL – Disables integration (I-part of controller). 0.1...3600.0 = Integration time (seconds). See 4001 for adjustment procedure.</p>															
	<p>A = Error B = Error value step C = Controller output with Gain = 1 D = Controller output with Gain = 10</p>															
4003	<p>DERIVATION TIME</p> <p>Defines the PID Controller's derivation time.</p> <ul style="list-style-type: none"> • You can add the derivative of the error to the PID controller output. The derivative is the error value's rate of change. For example, if the process error value changes linearly, the derivative is a constant added to the PID controller output. • The error-derivative is filtered with a 1-pole filter. The time constant of the filter is defined by parameter 4004 PID DERIV FILTER. <p>0.0...10.0 – Derivation time (seconds)</p>															
	<p>Process Error Value PID output Gain P 4001 D-part of controller output P 4003</p>															
4004	<p>PID DERIV FILTER</p> <p>Defines the filter time constant for the error-derivative part of the PID controller output.</p> <ul style="list-style-type: none"> • Before being added to the PID controller output, the error-derivative is filtered with a 1-pole filter. • Increasing the filter time smooths the error-derivative, reducing noise. <p>0.0...10.0 – Filter time constant (seconds).</p>															
4005	<p>ERROR VALUE INV</p> <p>Selects either a normal or inverted relationship between the feedback signal and the drive speed.</p> <p>0 = NO – Normal, a decrease in feedback signal increases drive speed. Error = Ref - Fbk 1 = YES – Inverted, a decrease in feedback signal decreases drive speed. Error = Fbk - Ref</p>															
4006	<p>UNITS</p> <p>Selects the unit for the PID controller actual values. (PID1 parameters 0128, 0130, and 0132). See parameter 3405 for list of available units.</p>															
4007	<p>UNIT SCALE</p> <p>Defines the decimal point location in PID controller actual values.</p> <ul style="list-style-type: none"> • Enter the decimal point location counting in from the right of the entry. • See table for example using pi (3.14159). <table border="1"> <thead> <tr> <th>4007 Value</th> <th>Entry</th> <th>Display</th> </tr> </thead> <tbody> <tr> <td>0</td> <td>0003</td> <td>3</td> </tr> <tr> <td>1</td> <td>0031</td> <td>3.1</td> </tr> <tr> <td>2</td> <td>0314</td> <td>3.14</td> </tr> <tr> <td>3</td> <td>3142</td> <td>3.142</td> </tr> </tbody> </table>	4007 Value	Entry	Display	0	0003	3	1	0031	3.1	2	0314	3.14	3	3142	3.142
4007 Value	Entry	Display														
0	0003	3														
1	0031	3.1														
2	0314	3.14														
3	3142	3.142														

Code	Description	
4008	<p>0% VALUE</p> <p>Defines (together with the next parameter) the scaling applied to the PID controller's actual values (PID1 parameters 0128, 0130, and 0132).</p> <p>Units and scale are defined by parameters 4006 and 4007.</p>	
4009	<p>100% VALUE</p> <p>Defines (together with the previous parameter) the scaling applied to the PID controller's actual values.</p> <p>Units and scale are defined by parameters 4006 and 4007.</p>	
4010	<p>SET POINT SEL</p> <p>Defines the reference signal source for the PID controller.</p> <ul style="list-style-type: none"> Parameter has no significance when the PID regulator is by-passed (see 8121 REG BYPASS CTRL). <p>0 = keypad – Control panel provides reference.</p> <p>1 = AI1 – Analog input 1 provides reference.</p> <p>2 = AI2 – Analog input 2 provides reference.</p> <p>8 = COMM – Fieldbus provides reference.</p> <p>9 = COMM + AI1 – Defines a fieldbus and analog input 1 (AI1) combination as the reference source. See Analog Input Reference Correction below.</p> <p>10 = COMM * AI1 – Defines a fieldbus and analog input 1 (AI1) combination as the reference source. See Analog Input Reference Correction below.</p> <p>11 = DI3U, 4D(RNC) – Digital inputs, acting as a motor potentiometer control, provide reference.</p> <ul style="list-style-type: none"> DI3 increases the speed (the U stands for “up”) DI4 decreases the reference (the D stands for “down”). Parameter 2205 ACCELER TIME 2 controls the reference signal's rate of change. R = Stop command resets the reference to zero. NC = Reference value is not copied. <p>12 = DI3U, 4D(NC) – Same as DI3U, 4D(RNC) above, except:</p> <ul style="list-style-type: none"> Stop command does not reset reference to zero. At restart the motor ramps up, at the selected acceleration rate, to the stored reference. <p>13 = DI5U, 6D(NC) – Same as DI3U, 4D(NC) above, except:</p> <ul style="list-style-type: none"> Uses digital inputs DI5 and DI6. <p>14 = AI1 + AI2 – Defines an analog input 1 (AI1) and analog input 2 (AI2) combination as the reference source. See Analog Input Reference Correction below.</p> <p>15 = AI1 * AI2 – Defines an analog input 1 (AI1) and analog input 2 (AI2) combination as the reference source. See Analog Input Reference Correction below.</p> <p>16 = AI1 - AI2 – Defines an analog input 1 (AI1) and analog input 2 (AI2) combination as the reference source. See Analog Input Reference Correction below.</p> <p>17 = AI1/AI2 – Defines an analog input 1 (AI1) and analog input 2 (AI2) combination as the reference source. See Analog Input Reference Correction below.</p> <p>19 = INTERNAL – A constant value set using parameter 4011 provides reference.</p> <p>20 = PID2OUT – Defines PID controller 2 output (parameter 0127 PID 2 OUTPUT) as the reference source.</p>	

Code	Description										
	<p>Analog Input Reference Correction Parameter values 9, 10, and 14...17 use the formula in the following table.</p> <table border="1"> <thead> <tr> <th>Value Setting</th> <th>AI reference is calculated as following:</th> </tr> </thead> <tbody> <tr> <td>C + B</td> <td>C value + (B value - 50% of reference value)</td> </tr> <tr> <td>C * B</td> <td>C value * (B value / 50% of reference value)</td> </tr> <tr> <td>C - B</td> <td>(C value + 50% of reference value) - B value</td> </tr> <tr> <td>C / B</td> <td>(C value * 50% of reference value) / B value</td> </tr> </tbody> </table> <p>Where:</p> <ul style="list-style-type: none"> C = Main Reference value (= COMM for values 9, 10 and = AI1 for values 14...17). B = Correcting reference (= AI1 for values 9, 10 and = AI2 for values 14...17). <p>Example: The figure shows the reference source curves for value settings 9, 10, and 14...17, where:</p> <ul style="list-style-type: none"> C = 25%. P 4012 SETPOINT MIN = 0. P 4013 SETPOINT MAX = 100. B varies along the horizontal axis. 	Value Setting	AI reference is calculated as following:	C + B	C value + (B value - 50% of reference value)	C * B	C value * (B value / 50% of reference value)	C - B	(C value + 50% of reference value) - B value	C / B	(C value * 50% of reference value) / B value
Value Setting	AI reference is calculated as following:										
C + B	C value + (B value - 50% of reference value)										
C * B	C value * (B value / 50% of reference value)										
C - B	(C value + 50% of reference value) - B value										
C / B	(C value * 50% of reference value) / B value										
4011	<p>INTERNAL SETPNT Sets a constant value used for the process reference. Units and scale are defined by parameters 4006 and 4007.</p>										
4012	<p>SETPOINT MIN Sets the minimum value for the reference signal source. See parameter 4010.</p>										
4013	<p>SETPOINT MAX Sets the maximum value for the reference signal source. See parameter 4010.</p>										
4014	<p>FBK SEL Defines the PID controller feedback (actual signal).</p> <ul style="list-style-type: none"> You can define a combination of two actual values (ACT1 and ACT2) as the feedback signal. Use parameter 4016 to define the source for actual value 1 (ACT1). Use parameter 4017 to define the source for actual value 2 (ACT2). <p>1 = ACT1 – Actual value 1 (ACT1) provides the feedback signal. 2 = ACT1-ACT2 – ACT1 minus ACT2 provides the feedback signal. 3 = ACT1+ACT2 – ACT1 plus ACT2 provides the feedback signal. 4 = ACT1*ACT2 – ACT1 times ACT2 provides the feedback signal. 5 = ACT1/ACT2 – ACT1 divided by ACT2 provides the feedback signal. 6 = MIN (ACT1, 2) – The smaller of ACT1 or ACT2 provides the feedback signal. 7 = MAX (ACT1, 2) – The greater of ACT1 or ACT2 provides the feedback signal. 8 = SQRT (ACT1-2) – Square root of the value for ACT1 minus ACT2 provides the feedback signal. 9 = SQA1 + SQA2 – Square root of ACT1 plus the square root of ACT2 provides the feedback signal. 10 = SQRT (ACT1) – Square root of ACT1 provides the feedback signal. 11 = COMM FBK 1 – Signal 0158 PID COMM VALUE 1 provides the feedback signal. 12 = COMM FBK 2 – Signal 0159 PID COMM VALUE 2 provides the feedback signal. 13 = AVE (ACT1, 2) – The average fo ACT1 and ACT2 provides the feedback signal.</p>										
4015	<p>FBK MULTIPLIER Defines an extra multiplier for the PID FBK value defined by parameter 4014. Used mainly in applications where the flow is calculated from the pressure difference. 0 = NOT SEL -32.768...32.767 = Multiplier applied to the signal defined by parameter 4014 FBK SEL.</p> <p>Example: FBK = Multiplier × $\sqrt{A1 - A2}$</p>										

Code	Description																								
4016	<p>ACT1 INPUT</p> <p>Defines the source for actual value 1 (ACT1). See also parameter 4018 ACT1 MINIMUM.</p> <p>1 = AI1 – Uses analog input 1 for ACT1. 2 = AI2 – Uses analog input 2 for ACT1. 3 = CURRENT – Uses current for ACT1. 4 = TORQUE – Uses torque for ACT1. 5 = POWER – Uses power for ACT1. 6 = COMM ACT 1 – Uses value of signal 0158 PID COMM VALUE 1 for ACT1. 7 = COMM ACT 2 – Uses value of signal 0159 PID COMM VALUE 2 for ACT1.</p>																								
4017	<p>ACT2 INPUT</p> <p>Defines the source for actual value 2 (ACT2). See also parameter 4020 ACT2 MINIMUM.</p> <p>1 = AI1 – Uses analog input 1 for ACT2. 2 = AI2 – Uses analog input 2 for ACT2. 3 = CURRENT – Uses current for ACT2. 4 = TORQUE – Uses torque for ACT2. 5 = POWER – Uses power for ACT2. 6 = COMM ACT 1 – Uses value of signal 0158 PID COMM VALUE 1 for ACT2. 7 = COMM ACT 2 – Uses value of signal 0159 PID COMM VALUE 2 for ACT2.</p>																								
4018	<p>ACT1 MINIMUM</p> <p>Sets the minimum value for ACT1.</p> <ul style="list-style-type: none"> • Scales the source signal used as the actual value ACT1 (defined by parameter 4016 ACT1 INPUT). For parameter 4016 values 6 (COMM ACT 1) and 7 (COMM ACT 2) scaling is not done. <table border="1"> <thead> <tr> <th>Par 4016</th> <th>Source</th> <th>Source min.</th> <th>Source max.</th> </tr> </thead> <tbody> <tr> <td>1</td> <td>Analog input 1</td> <td>1301 MINIMUM AI1</td> <td>1302 MAXIMUM AI1</td> </tr> <tr> <td>2</td> <td>Analog input 2</td> <td>1304 MINIMUM AI2</td> <td>1305 MAXIMUM AI2</td> </tr> <tr> <td>3</td> <td>Current</td> <td>0</td> <td>2 · nominal current</td> </tr> <tr> <td>4</td> <td>Torque</td> <td>-2 · nominal torque</td> <td>2 · nominal torque</td> </tr> <tr> <td>5</td> <td>Power</td> <td>-2 · nominal power</td> <td>2 · nominal power</td> </tr> </tbody> </table> <ul style="list-style-type: none"> • See the figure: A = Normal; B = Inversion (ACT1 MINIMUM > ACT1 MAXIMUM) 	Par 4016	Source	Source min.	Source max.	1	Analog input 1	1301 MINIMUM AI1	1302 MAXIMUM AI1	2	Analog input 2	1304 MINIMUM AI2	1305 MAXIMUM AI2	3	Current	0	2 · nominal current	4	Torque	-2 · nominal torque	2 · nominal torque	5	Power	-2 · nominal power	2 · nominal power
Par 4016	Source	Source min.	Source max.																						
1	Analog input 1	1301 MINIMUM AI1	1302 MAXIMUM AI1																						
2	Analog input 2	1304 MINIMUM AI2	1305 MAXIMUM AI2																						
3	Current	0	2 · nominal current																						
4	Torque	-2 · nominal torque	2 · nominal torque																						
5	Power	-2 · nominal power	2 · nominal power																						
4019	<p>ACT1 MAXIMUM</p> <p>Sets the maximum value for ACT1. See 4018 ACT1 MINIMUM.</p>																								
4020	<p>ACT2 MINIMUM</p> <p>Sets the minimum value for ACT2. See 4018 ACT1 MINIMUM.</p>																								
4021	<p>ACT2 MAXIMUM</p> <p>Sets the maximum value for ACT2. See 4018 ACT1 MINIMUM.</p>																								
4022	<p>SLEEP SELECTION</p> <p>Defines the control for the PID sleep function.</p> <p>0 = NOT SEL– Disables the PID sleep control function.</p> <p>1 = DI1 – Defines digital input DI1 as the control for the PID sleep function.</p> <ul style="list-style-type: none"> • Activating the digital input activates the sleep function. • De-activating the digital input restores PID control. <p>2...6 = DI2...DI6 – Defines digital input DI2...DI6 as the control for the PID sleep function.</p> <ul style="list-style-type: none"> • See DI1 above. <p>7 = INTERNAL – Defines the output frequency, process reference, and process actual value as the control for the PID sleep function. Refer to parameters 4025 WAKE-UP DEV and 4023 PID SLEEP LEVEL.</p> <p>-1 = DI1(INV) – Defines an inverted digital input DI1 as the control for the PID sleep function.</p> <ul style="list-style-type: none"> • De-activating the digital input activates the sleep function. • Activating the digital input restores PID control. <p>-2...-6 = DI2(INV)...DI6(INV) – Defines an inverted digital input DI2...DI6 as the control for the PID sleep function.</p> <ul style="list-style-type: none"> • See DI1(INV) above. 																								

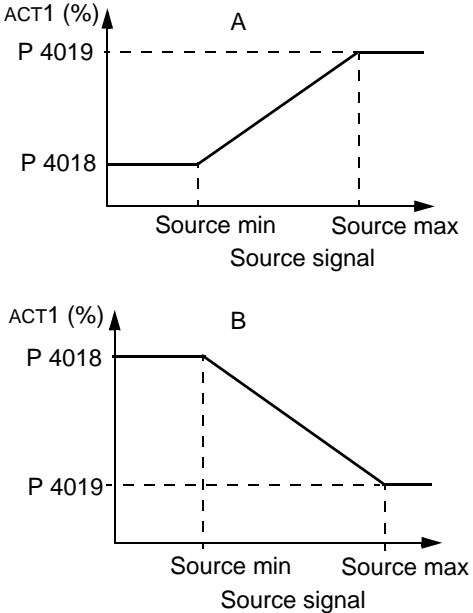

Code	Description	
4023	<p>PID SLEEP LEVEL</p> <p>Sets the motor speed / frequency that enables the PID sleep function – a motor speed / frequency below this level, for at least the time period 4024 PID SLEEP DELAY enables the PID sleep function (stopping the drive).</p> <ul style="list-style-type: none"> Requires 4022 = 7 INTERNAL. See figure: A = PID output level; B = PID process feedback. 	
4024	<p>PID SLEEP DELAY</p> <p>Sets the time delay for the PID sleep function – a motor speed / frequency below 4023 PID SLEEP LEVEL for at least this time period enables the PID sleep function (stopping the drive). See 4023 PID SLEEP LEVEL above.</p>	
4025	<p>WAKE-UP DEV</p> <p>Defines the wake-up deviation – a deviation from the setpoint greater than this value, for at least the time period 4026 WAKE-UP DELAY, re-starts the PID controller.</p> <ul style="list-style-type: none"> Parameters 4006 and 4007 define the units and scale. Parameter 4005 = 0, Wake-up level = Setpoint - Wake-up deviation. Parameter 4005 = 1, Wake-up level = Setpoint + Wake-up deviation. Wake-up level can be above or below setpoint. <p>See figures:</p> <ul style="list-style-type: none"> C = Wake-up level when parameter 4005 = 1 D = Wake-up level when parameter 4005 = 0 E = Feedback is above wake-up level and lasts longer than 4026 WAKE-UP DELAY – PID function wakes up. F = Feedback is below wake-up level and lasts longer than 4026 WAKE-UP DELAY – PID function wakes up. 	
4026	<p>WAKE-UP DELAY</p> <p>Defines the wake-up delay – a deviation from the setpoint greater than 4025 WAKE-UP DEV, for at least this time period, re-starts the PID controller.</p>	
4027	<p>PID 1 PARAM SET</p> <p>Process PID (PID1) has two separate sets of parameters, PID set 1 and PID set 2.</p> <ul style="list-style-type: none"> PID set 1 uses parameters 4001...4026. PID set 2 uses parameters 4101...4126. <p>PID 1 PARAM SET defines which set is selected.</p> <p>0 = SET 1 – PID Set 1 (parameters 4001...4026) is active.</p> <p>1 = DI1 – Defines digital input DI1 as the control for PID Set selection.</p> <ul style="list-style-type: none"> Activating the digital input selects PID Set 2. De-activating the digital input selects PID Set 1. <p>2...6 = DI2...DI6 – Defines digital input DI2...DI6 as the control for PID Set selection.</p> <ul style="list-style-type: none"> See DI1 above. <p>7 = SET 2 – PID Set 2 (parameters 4101...4126) is active.</p> <p>-1 = DI1(INV) – Defines an inverted digital input DI1 as the control for PID Set selection.</p> <ul style="list-style-type: none"> Activating the digital input selects PID Set 1. De-activating the digital input selects PID Set 2. <p>-2...-6 = DI2(INV)...DI6(INV) – Defines an inverted digital input DI2...DI6 as the control for PID Set selection.</p> <ul style="list-style-type: none"> See DI1(INV) above. 	

Group 41: Process PID Set 2

Parameters of this group belong to PID parameter set 2. The operation of parameters 4101...4126 is analogous with set 1 parameters 4001...4026.

PID parameter set 2 can be selected by parameter 4027 PID 1 PARAM SET.

Group 41: Process PID Set 2	
Code	Description
4101	See 4001 ...4026
...	
4126	

Group 42: External / Trimming PID

This group defines the parameters used for the second PID controller (PID2), which is used for the External / Trimming PID.

The operation of parameters 4201...4221 is analogous with Process PID set 1 (PID1) parameters 4001...4021.

Code	Description
4201 ... 4221	See 4001 ...4021
4228	<p>ACTIVATE</p> <p>Defines the source for enabling the external PID function.</p> <ul style="list-style-type: none"> Requires 4230 TRIM MODE = 0 NOT SEL. <p>0 = NOT SEL – Disables external PID control.</p> <p>1 = DI1 – Defines digital input DI1 as the control for enabling external PID control.</p> <ul style="list-style-type: none"> Activating the digital input enables external PID control. De-activating the digital input disables external PID control. <p>2...6 = DI2...DI6 – Defines digital input DI2...DI6 as the control for enabling external PID control.</p> <ul style="list-style-type: none"> See DI1 above. <p>7 = DRIVE RUN – Defines the start command as the control for enabling external PID control.</p> <ul style="list-style-type: none"> Activating the start command (drive is running) enables external PID control. <p>8 = ON – Defines the power-on as the control for enabling external PID control.</p> <ul style="list-style-type: none"> Activating power to the drive enables external PID control. <p>-1 = DI1(INV) – Defines an inverted digital input DI1 as the control for enabling external PID control.</p> <ul style="list-style-type: none"> Activating the digital input disables external PID control. De-activating the digital input enables external PID control. <p>-2...-6 = DI2(INV)...DI6(INV) – Defines an inverted digital input DI2...DI6 as the control for enabling external PID control.</p> <ul style="list-style-type: none"> See DI1(INV) above.
4229	<p>OFFSET</p> <p>Defines the offset for the PID output.</p> <ul style="list-style-type: none"> When PID is activated, output starts from this value. When PID is deactivated, output resets to this value. Parameter is active when 4230 TRIM MODE = 0 (trim mode is not active).
4230	<p>TRIM MODE</p> <p>Selects the type of trim, if any. Using the trim it is possible to combine a corrective factor to the drive reference.</p> <p>0 = NOT SEL – Disables the trim function.</p> <p>1 = PROPORTIONAL – Adds a trim factor that is proportional to the Hz reference.</p> <p>2 = DIRECT – Adds a trim factor based on the control loop's maximum limit.</p>
4231	<p>TRIM SCALE</p> <p>Defines the multiplier (as a percent, plus or minus) used in the trim mode.</p>

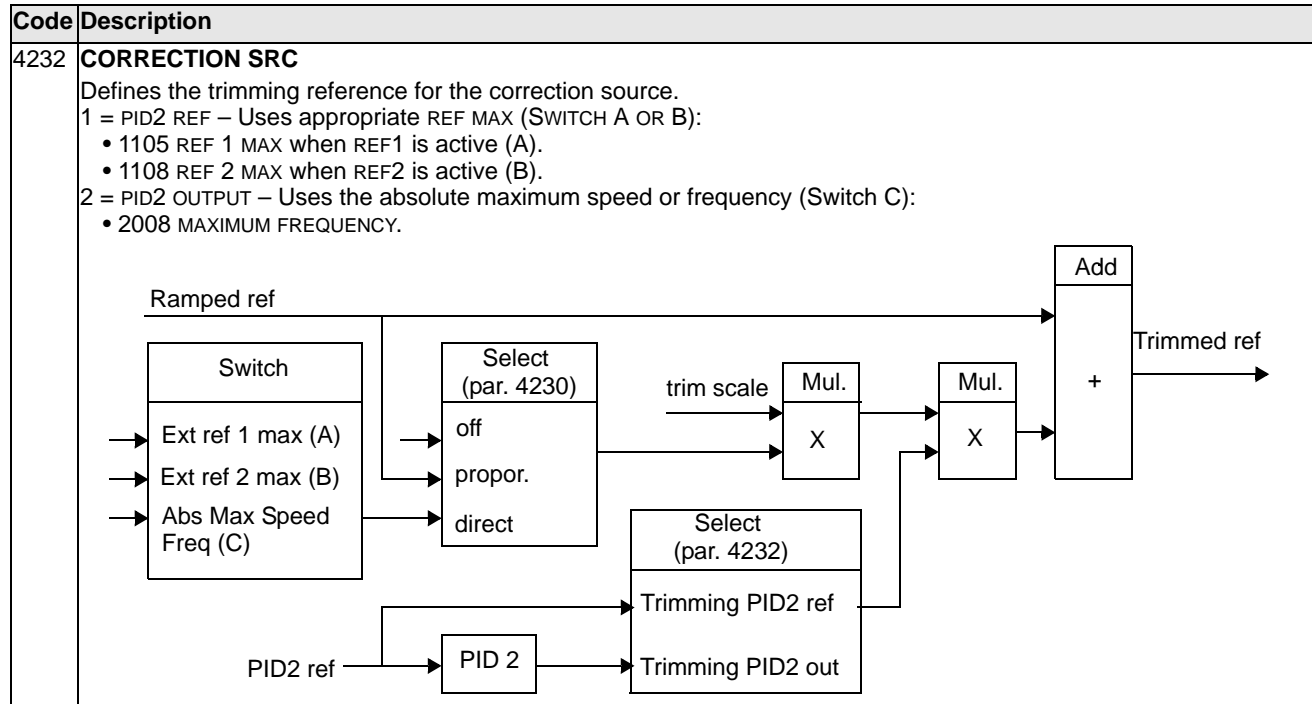

Group 51: Ext Comm Module

This group defines set-up variables for a fieldbus adapter (FBA) communication module. For more information on these parameters, refer to the user's manual supplied with the FBA module.

Code	Description
5101	<p>FBA TYPE</p> <p>Displays the type of the connected fieldbus adapter module.</p> <p>0 = NOT DEFINED – Module not found, or not properly connected, or parameter 9802 is not set to 4 (EXT FBA).</p> <p>1 = PROFIBUS-DP</p> <p>16 = INTERBUS</p> <p>21 = LONWORKS</p> <p>32 = CANOPEN</p> <p>37 = DEVICENET</p> <p>64 = MODBUS PLUS</p> <p>101 = CONTROLNET</p> <p>128 = ETHERNET</p>
5102 ... 5126	<p>FB PAR 2...FB PAR 26</p> <p>Refer to communication module documentation for more information on these parameters.</p>
5127	<p>FBA PAR REFRESH</p> <p>Validates any changed fieldbus parameter settings.</p> <p>0 = DONE – Refreshing done.</p> <p>1 = REFRESH – Refreshing.</p> <ul style="list-style-type: none"> • After refreshing, the value reverts automatically to DONE.
5128	<p>FILE CPI FW REV</p> <p>Displays the CPI firmware revision of the drive's fieldbus adapter configuration file. Format is xyz where:</p> <ul style="list-style-type: none"> • x = major revision number • y = minor revision number • z = correction number <p>Example: 107 = revision 1.07</p>
5129	<p>FILE CONFIG ID</p> <p>Displays the revision of the drive's fieldbus adapter module's configuration file identification.</p> <p>File configuration information is drive application program-dependent.</p>
5130	<p>FILE CONFIG REV</p> <p>Contains the revision of the drive's fieldbus adapter module configuration file.</p> <p>Example: 1 = revision 1</p>
5131	<p>FBA STATUS</p> <p>Contains the status of the adapter module.</p> <p>0 = IDLE – Adapter not configured.</p> <p>1 = EXECUT INIT – Adapter is initializing.</p> <p>2 = TIME OUT – A timeout has occurred in the communication between the adapter and the drive.</p> <p>3 = CONFIG ERROR – Adapter configuration error.</p> <ul style="list-style-type: none"> • The revision code of the adapter's CPI firmware revision is older than required CPI firmware version defined in the drive's configuration file (parameter 5132 < 5128). <p>4 = OFF-LINE – Adapter is off-line.</p> <p>5 = ON-LINE – Adapter is on-line.</p> <p>6 = RESET – Adapter is performing a hardware reset.</p>
5132	<p>FBA CPI FW REV</p> <p>Contains the revision of the module's CPI program. Format is xyz where:</p> <ul style="list-style-type: none"> • x = major revision number • y = minor revision number • z = correction number <p>Example: 107 = revision 1.07</p>
5133	<p>FBA APPL FW REV</p> <p>Contains the revision of the module's application program Format is xyz (see parameter 5132).</p>

Group 53: EFB Protocol

This group defines set-up variables used for an embedded fieldbus (EFB) communication protocol. The standard EFB protocol in the ACS510 is Modbus. See "Embedded Fieldbus" starting on page 143.

Code	Description
5301	EFB PROTOCOL ID Contains the identification and program revision of the protocol. Format: XXYY, where xx = protocol ID, and YY = program revision.
5302	EFB STATION ID Defines the node address of the RS485 link. The node address on each unit must be unique.
5303	EFB BAUD RATE Defines the communication speed of the RS485 link in kbits per second (kbits/s). 1.2 kb/s 2.4 kb/s 4.8 kb/s 9.6 kb/s 19.2 kb/s 38.4 kb/s 57.6 kb/s 76.8 kb/s
5304	EFB PARITY Defines the data length, parity and stop bits to be used with the RS485 link communication. The same settings must be used in all on-line stations. 0 = 8 NONE 1 – 8 data bits, no parity, one stop bit. 1 = 8 NONE 2 – 8 data bits, no parity, two stop bits. 2 = 8 EVEN 1 – 8 data bits, even parity, one stop bit. 3 = 8 ODD 1 – 8 data bits, odd parity, one stop bit.
5305	EFB CTRL PROFILE Selects the communication profile used by the EFB protocol. 0 = ABB DRV LIM – Operation of Control/Status Words conforms to ABB Drives Profile, as used in ACS400. 1 = DCU PROFILE – Operation of Control/Status Words conforms to 32-bit DCU Profile. 2 = ABB DRV FULL – Operation of Control/Status Words conforms to ABB Drives Profile, as used in ACS600/800.
5306	EFB OK MESSAGES Contains a count of valid messages received by the drive. During normal operation, this counter is increasing constantly.
5307	EFB CRC ERRORS Contains a count of the messages with a CRC error received by the drive. For high counts, check: <ul style="list-style-type: none"> • Ambient electro-magnetic noise levels – high noise levels generate errors. • CRC calculations for possible errors.
5308	EFB UART ERRORS Contains a count of the messages with a character error received by the drive.
5309	EFB STATUS Contains the status of the EFB protocol. 0 = IDLE – EFB protocol is configured, but not receiving any messages. 1 = EXECUT INIT – EFB protocol is initializing. 2 = TIME OUT – A timeout has occurred in the communication between the network master and the EFB protocol. 3 = CONFIG ERROR – EFB protocol has a configuration error. 4 = OFF-LINE – EFB protocol is receiving messages that are NOT addressed to this drive. 5 = ON-LINE – EFB protocol is receiving messages that are addressed to this drive. 6 = RESET – EFB protocol is performing a hardware reset. 7 = LISTEN ONLY – EFB protocol is in listen-only mode.
5310	EFB PAR 10 Specifies the parameter mapped to Modbus Register 40005.

Code	Description
5311	EFB PAR 11 Specifies the parameter mapped to Modbus Register 40006.
5312	EFB PAR 12 Specifies the parameter mapped to Modbus Register 40007.
5313	EFB PAR 13 Specifies the parameter mapped to Modbus Register 40008.
5314	EFB PAR 14 Specifies the parameter mapped to Modbus Register 40009.
5315	EFB PAR 15 Specifies the parameter mapped to Modbus Register 40010.
5316	EFB PAR 16 Specifies the parameter mapped to Modbus Register 40011.
5317	EFB PAR 17 Specifies the parameter mapped to Modbus Register 40012.
5318	EFB PAR 18 For Modbus: Sets additional delay in milliseconds before the ACS510 begins transmitting response to the master request.
5319	EFB PAR 19 ABB Drives profile (ABB DRV LIM or ABB DRV FULL) Control Word. Read only copy of the Fieldbus Control Word.
5320	EFB PAR 20 ABB Drives profile (ABB DRV LIM or ABB DRV FULL) Status Word. Read only copy of the Fieldbus Status Word.

Group 81: PFC Control

This group defines a Pump-Fan Control (PFC) mode of operation. The major features of PFC control are:

- The ACS510 controls the motor of pump no. 1, varying the motor speed to control the pump capacity. This motor is the speed regulated motor.
- Direct line connections power the motor of pump no. 2 and pump no.3...pump no.6,etc (pump 4,5,6 need RO extension module OREL-01). The ACS510 switches pump no. 2 (and then pump no. 3...pump no.6, etc.) on and off as needed. These motors are auxiliary motors.
- The ACS510 PID control uses two signals: a process reference and an actual value feedback. The PID controller adjusts the speed (frequency) of the first pump such that the actual value follows the process reference.
- When demand (defined by the process reference) exceeds the first motor's capacity (user defined as a frequency limit), the PFC control automatically starts an auxiliary pump. The PFC also reduces the speed of the first pump to account for the auxiliary pump's addition to total output. Then, as before, the PID controller adjusts the speed (frequency) of the first pump such that the actual value follows the process reference. If demand continues to increase, PFC adds additional auxiliary pumps, using the same process.
- When demand drops, such that the first pump speed falls below a minimum limit (user defined by a frequency limit), the PFC control automatically stops an auxiliary pump. The PFC also increases the speed of the first pump to account for the auxiliary pump's missing output.
- An Interlock function (when enabled) identifies off-line (out of service) motors, and the PFC control skips to the next available motor in the sequence.
- An Autochange function (when enabled and with the appropriate switchgear) equalizes duty time between the pump motors. Autochange periodically increments the position of each motor in the rotation – the speed regulated motor becomes the last auxiliary motor, the first auxiliary motor becomes the speed regulated motor, etc.
- The soft-start function ensures that all motors are started smoothly:When new motors need to be started due to increasing pumping capacity need, they are powered up by the drive as follows:
 - When motor 1 reaches the AC powerline frequency, it is disconnected from the drive and switched to direct on-line connection(with a slight delay in between).
 - Motor 2 is connected to drive output. After a slight delay the motor speed is increased to fulfil the pumping capacity needed.
 - Motor 3...6 are started accoring to the same routine.
 - The motor stopping routine follows always the normal PFC routine.
- This is the way PFC "Soft Start" controls the motors when starting new motors, See the follow diagram:
 - Drive is started and RO1 is closed. Modulation is not allowed.

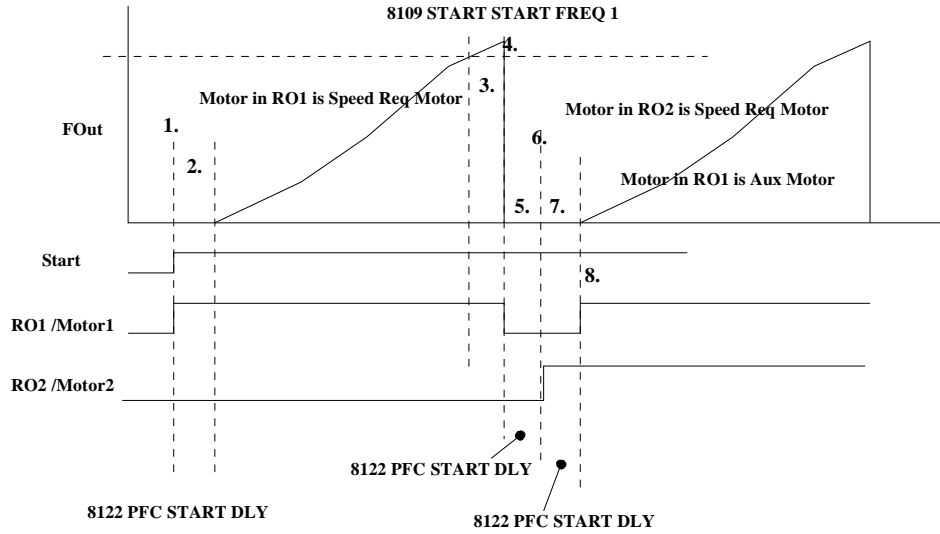

- Drive waits for PFC Start Delay(parameter 8122). Modulation is not allowed because drive has to wait that all contactor are stabilized.
- Modulation is allowed. Modulation starts from zero speed. After F_{out} rises over Start Frequency 1, Aux. Mot. Start Delay starts (parameter 8115).
- When Aux. Mot. Start Delay elapses then drive coasts to stop and RO1 is opened.
- Drive waits for PFC Start Delay (parameter 8122). Meaning of this delay it to wait contactors to stabilize. If there is some oscillation in Motor 1 contactors when closing RO2, then contactors might go to wrong state.
- Drive close RO2. This is new plae for Speed Regulated Motor. Modulation is not allow yet.
- Drive waits for PFC Start Delay (parameter 8122). Modulation is not allowed because the drive has to wait that all contactors are stabilized.
- Drive close RO1. Motor in RO1 is connected directly to the network(constant speed) and modulation is allowed. Drive start accelerating from zero in RO2.
- Stopping motors goes like in standard PFC. See the figure.

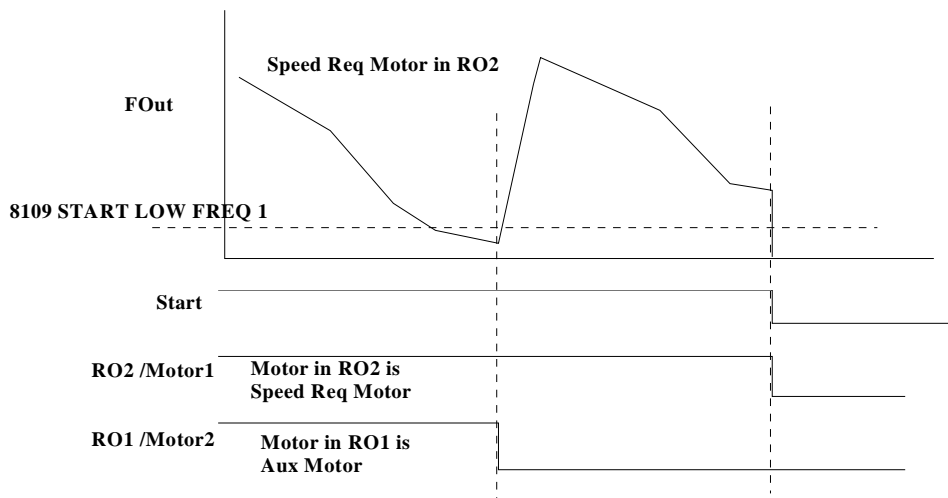

- In next two pages show the typical circuit diagram of SPFC control.

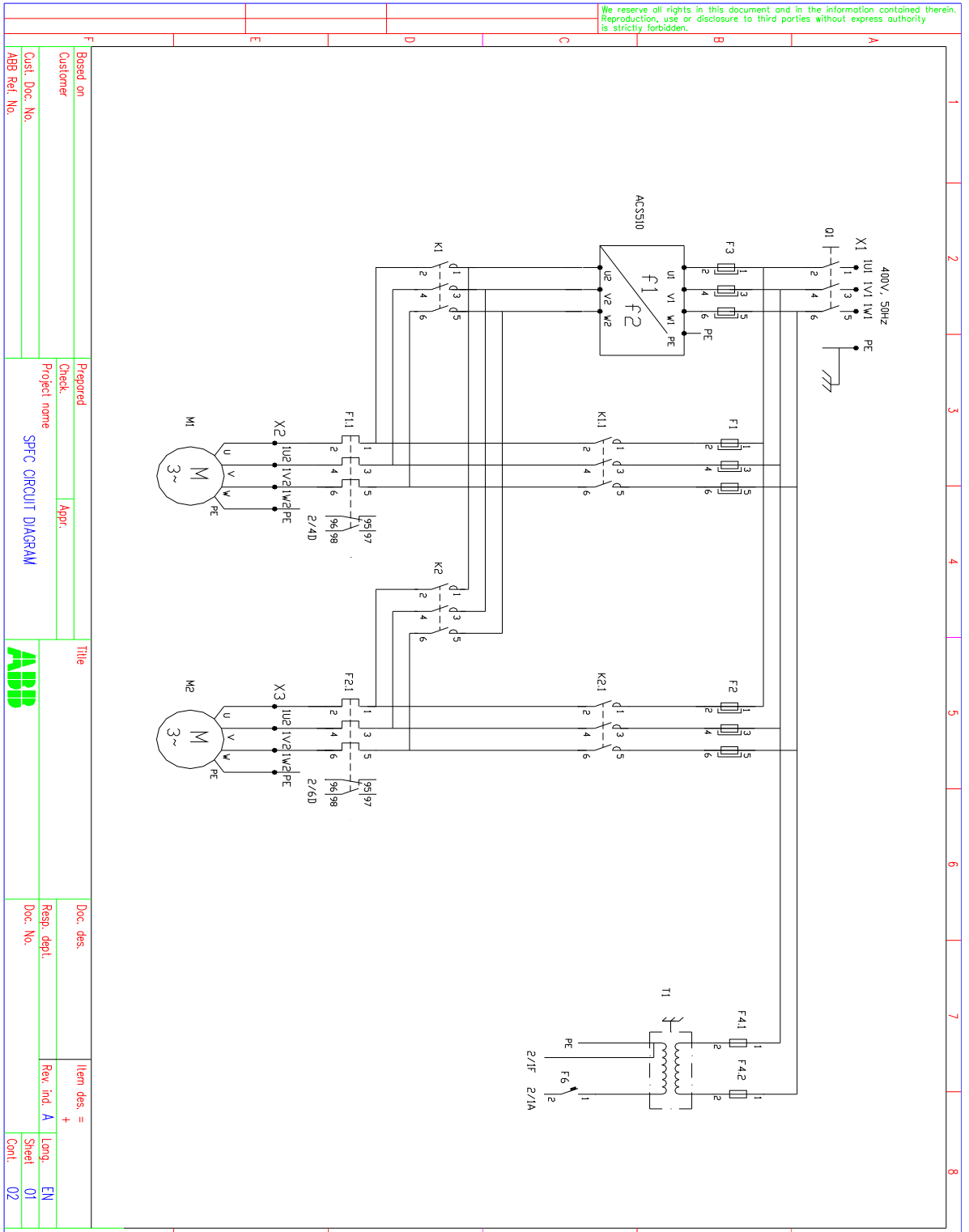

We reserve all rights in this document and in the information contained therein. Reproduction, use or disclosure to third parties without express authority is strictly forbidden.

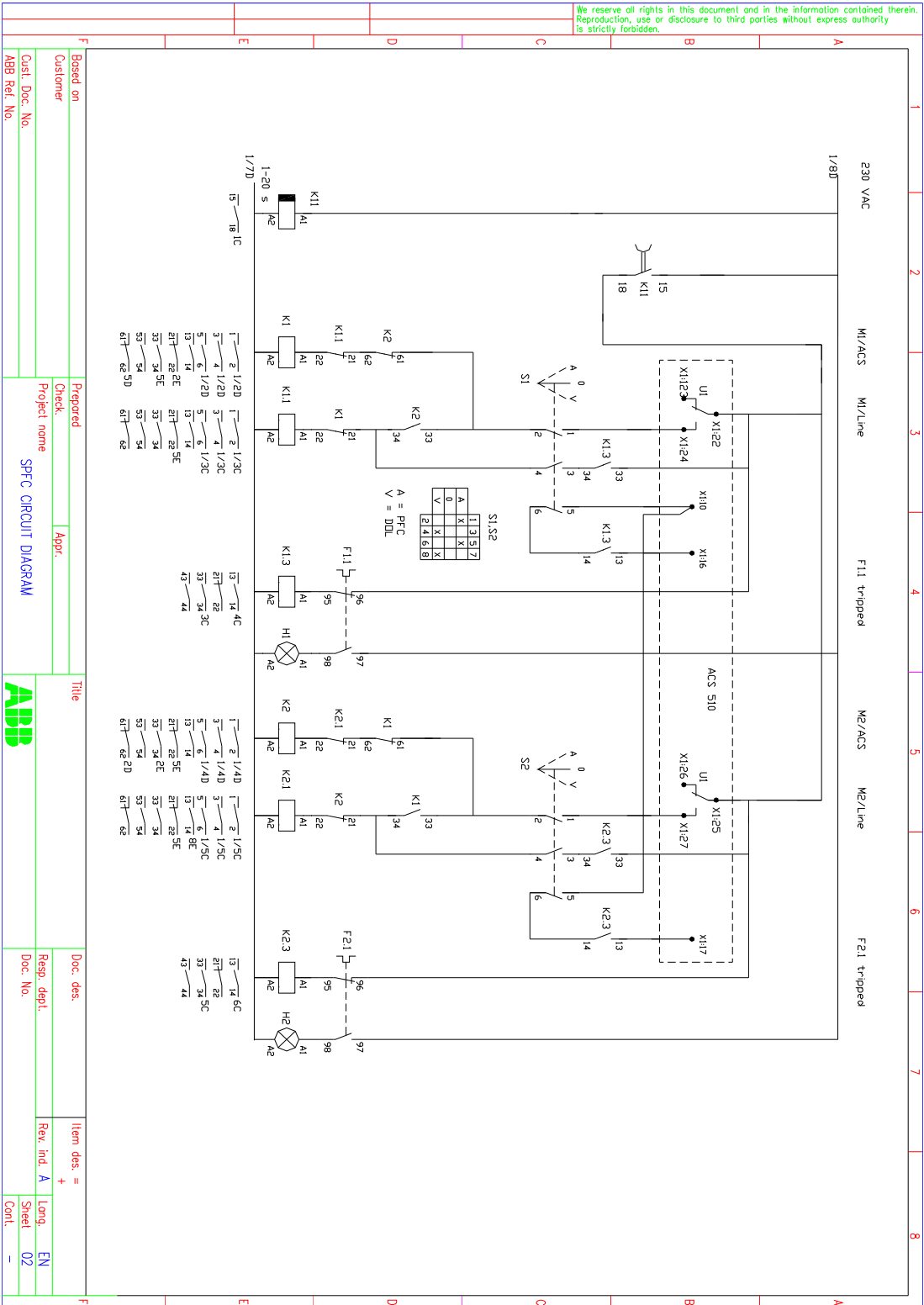

Based on	Check.	Appr.	Title	Doc. des.	Item des. = +
Customer	Project name		SFC CIRCUIT DIAGRAM	Resp. dept.	Rev. ind. A
ABB Ref. No.				Doc. No.	Long. EN
				Sheet 02	Cont. -

Code	Description
8111	<p>START FREQ 3</p> <p>Sets the frequency limit used to start the third to the sixth auxiliary motor.</p> <ul style="list-style-type: none"> See 8109 START FREQ 1 for a complete description of the operation. <p>The third auxiliary motor starts if:</p> <ul style="list-style-type: none"> Two auxiliary motors are running. ACS510 output frequency exceeds the limit: 8111 + 1 Hz. Output frequency stays above the relaxed limit (8111 - 1 Hz) for at least the time: 8115 AUX MOT START D. Same process for the fourth motor to the sixth motor.
8112	<p>LOW FREQ 1</p> <p>Sets the frequency limit used to stop the first auxiliary motor. The first auxiliary motor stops if:</p> <ul style="list-style-type: none"> The first auxiliary motor is running alone. ACS510 output frequency drops below the limit: 8112 - 1. Output frequency stays below the relaxed limit (8112 + 1 Hz) for at least the time: 8116 AUX MOT STOP D. <p>After the first auxiliary motor stops:</p> <ul style="list-style-type: none"> Output frequency increases by the value = (8109 START FREQ 1) - (8112 LOW FREQ 1). In effect, the output of the speed regulated motor increases to compensate for the loss of the auxiliary motor. <p>See figure, where:</p> <ul style="list-style-type: none"> A = (8109 START FREQ 1) - (8112 LOW FREQ 1) B = Output frequency decrease during the stop delay. C = Diagram showing auxiliary motor's run status as frequency decreases (1 = On). Grey path = Shows hysteresis – if time is reversed, the path backwards is not the same. For details on the path for starting, see the diagram at 8109 START FREQ 1. <p>Note! 8112 LOW FREQ 1 value must be between:</p> <ul style="list-style-type: none"> (2007 MINIMUM FREQ) + 1. 8109 START FREQ 1
8113	<p>LOW FREQ 2</p> <p>Sets the frequency limit used to stop the second auxiliary motor.</p> <ul style="list-style-type: none"> See 8112 LOW FREQ 1 for a complete description of the operation. <p>The second auxiliary motor stops if:</p> <ul style="list-style-type: none"> Two auxiliary motors are running. ACS510 output frequency drops below the limit: 8113 - 1. Output frequency stays below the relaxed limit (8113 + 1 Hz) for at least the time: 8116 AUX MOT STOP D.
8114	<p>LOW FREQ 3</p> <p>Sets the frequency limit used to stop the third to the sixth auxiliary motor.</p> <ul style="list-style-type: none"> See 8112 LOW FREQ 1 for a complete description of the operation. <p>The third auxiliary motor stops if:</p> <ul style="list-style-type: none"> Three auxiliary motors are running. ACS510 output frequency drops below the limit: 8114 - 1. Output frequency stays below the relaxed limit (8114 + 1 Hz) for at least the time: 8116 AUX MOT STOP D. Same process for the fourth motor to the sixth motor.
8115	<p>AUX MOT START D</p> <p>Sets the Start Delay for the auxiliary motors.</p> <ul style="list-style-type: none"> The output frequency must remain above the start frequency limit (parameter 8109, 8110, or 8111) for this time period before the auxiliary motor starts. See 8109 START FREQ 1 for a complete description of the operation.
8116	<p>AUX MOT STOP D</p> <p>Sets the Stop Delay for the auxiliary motors.</p> <ul style="list-style-type: none"> The output frequency must remain below the low frequency limit (parameter 8112, 8113, or 8114) for this time period before the auxiliary motor stops. See 8112 LOW FREQ 1 for a complete description of the operation.

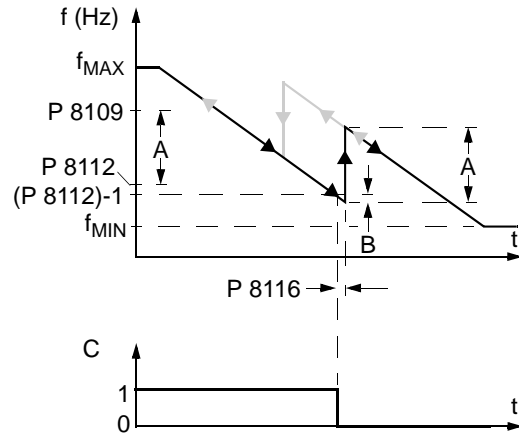

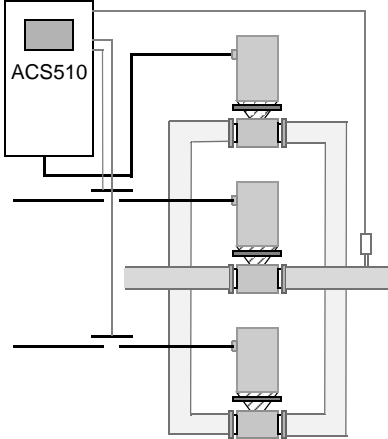
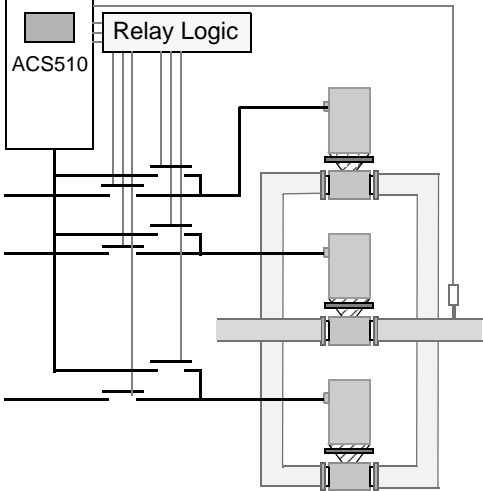
Code	Description
8117	<p>NR OF AUX MOT</p> <p>Sets the number of auxiliary motors.</p> <ul style="list-style-type: none"> • Each auxiliary motor requires a relay output, which the drive uses to send start/stop signals. • The Autochange function, if used, requires an additional relay output for the speed regulated motor. • The following describes the set-up of the required relay outputs. <p>Relay Outputs</p> <p>As noted above, each auxiliary motor requires a relay output, which the drive uses to send start/stop signals. The following describes how the drive keeps track of motors and relays.</p> <ul style="list-style-type: none"> • The ACS510 provides relay outputs RO1...RO3. • An external digital output module can be added to provide relay outputs RO4...RO6. • Parameters 1401...1403 and 1410...1412 define, respectively, how relays RO1...RO6 are used – the parameter value 31 PFC defines the relay as used for PFC. • The ACS510 assigns auxiliary motors to relays in ascending order. If the Autochange function is disabled, the first auxiliary motor is the one connected to the first relay with a parameter setting = 31 PFC, and so on. If the Autochange function is used, the assignments rotate. Initially, the speed regulated motor is the one connected to the first relay with a parameter setting = 31 PFC, the first auxiliary motor is the one connected to the second relay with a parameter setting = 31 PFC, and so on. <div style="display: flex; justify-content: space-around; align-items: flex-start;"> <div style="text-align: center;">  <p>Standard PFC mode</p> </div> <div style="text-align: center;">  <p>PFC with Autochange mode</p> </div> </div> <ul style="list-style-type: none"> • The fourth auxiliary motor uses the same reference step, low frequency and start frequency values as the third auxiliary motor.

Code	Description																																																																																																																																																																																																																			
	<ul style="list-style-type: none"> The table below shows the ACS510 PFC motor assignments for some typical settings in the Relay Output parameters (1401...1403 and 1410...1412), where the settings are either =31 (PFC), or =X (anything but 31), and where the Autochange function is disabled (8118 AUTOCHNG INTERV = 0). <table border="1"> <thead> <tr> <th colspan="2">Parameter Setting</th> <th colspan="6">ACS510 Relay Assignment</th> </tr> <tr> <th>1</th><th>4</th><th>0</th><th>1</th><th>2</th><th>3</th><th>7</th> <th colspan="6">Autochange Disabled</th> </tr> <tr> <th>1</th><th>4</th><th>0</th><th>1</th><th>2</th><th>3</th><th>7</th> <th>RO1</th><th>RO2</th><th>RO3</th><th>RO4</th><th>RO5</th><th>RO6</th> </tr> </thead> <tbody> <tr> <td>31</td><td>X</td><td>X</td><td>X</td><td>X</td><td>X</td><td>1</td> <td>Aux.</td><td>X</td><td>X</td><td>X</td><td>X</td><td>X</td> </tr> <tr> <td>31</td><td>31</td><td>X</td><td>X</td><td>X</td><td>X</td><td>2</td> <td>Aux.</td><td>Aux.</td><td>X</td><td>X</td><td>X</td><td>X</td> </tr> <tr> <td>31</td><td>31</td><td>31</td><td>X</td><td>X</td><td>X</td><td>3</td> <td>Aux.</td><td>Aux.</td><td>Aux.</td><td>X</td><td>X</td><td>X</td> </tr> <tr> <td>X</td><td>31</td><td>31</td><td>X</td><td>X</td><td>X</td><td>2</td> <td>X</td><td>Aux.</td><td>Aux.</td><td>X</td><td>X</td><td>X</td> </tr> <tr> <td>31</td><td>31</td><td>31</td><td>31</td><td>31</td><td>31</td><td>6</td> <td>Aux.</td><td>Aux.</td><td>Aux.</td><td>Aux.</td><td>Aux.</td><td>Aux.</td> </tr> <tr> <td>31</td><td>31</td><td>X</td><td>X</td><td>X</td><td>X</td><td>1*</td> <td>Aux.</td><td>Aux.</td><td>X</td><td>X</td><td>X</td><td>X</td> </tr> </tbody> </table> <p>* = One additional relay output for the PFC that is in use. One motor is in "sleep" when the other is rotating.</p> <ul style="list-style-type: none"> The table below shows the ACS510 PFC motor assignments for some typical settings in the Relay Output parameters (1401...1403 and 1410...1412), where the settings are either =31 (PFC), or =X (anything but 31), and where the Autochange function is enabled (8118 AUTOCHNG INTERV = value > 0). <table border="1"> <thead> <tr> <th colspan="2">Parameter Setting</th> <th colspan="6">ACS510 Relay Assignment</th> </tr> <tr> <th>1</th><th>4</th><th>0</th><th>1</th><th>2</th><th>3</th><th>7</th> <th colspan="6">Autochange Enabled</th> </tr> <tr> <th>1</th><th>4</th><th>0</th><th>1</th><th>2</th><th>3</th><th>7</th> <th>RO1</th><th>RO2</th><th>RO3</th><th>RO4</th><th>RO5</th><th>RO6</th> </tr> </thead> <tbody> <tr> <td>31</td><td>31</td><td>X</td><td>X</td><td>X</td><td>X</td><td>1</td> <td>PFC</td><td>PFC</td><td>X</td><td>X</td><td>X</td><td>X</td> </tr> <tr> <td>31</td><td>31</td><td>31</td><td>X</td><td>X</td><td>X</td><td>2</td> <td>PFC</td><td>PFC</td><td>PFC</td><td>X</td><td>X</td><td>X</td> </tr> <tr> <td>X</td><td>31</td><td>31</td><td>X</td><td>X</td><td>X</td><td>1</td> <td>X</td><td>PFC</td><td>PFC</td><td>X</td><td>X</td><td>X</td> </tr> <tr> <td>31</td><td>31</td><td>31</td><td>31</td><td>31</td><td>31</td><td>5</td> <td>PFC</td><td>PFC</td><td>PFC</td><td>PFC</td><td>PFC</td><td>PFC</td> </tr> <tr> <td>31</td><td>31</td><td>X</td><td>X</td><td>X</td><td>X</td><td>0**</td> <td>PFC</td><td>PFC</td><td>X</td><td>X</td><td>X</td><td>X</td> </tr> </tbody> </table> <p>** = No auxiliary motors, but the autochange function is in use. Working as a standard PID-control.</p>	Parameter Setting		ACS510 Relay Assignment						1	4	0	1	2	3	7	Autochange Disabled						1	4	0	1	2	3	7	RO1	RO2	RO3	RO4	RO5	RO6	31	X	X	X	X	X	1	Aux.	X	X	X	X	X	31	31	X	X	X	X	2	Aux.	Aux.	X	X	X	X	31	31	31	X	X	X	3	Aux.	Aux.	Aux.	X	X	X	X	31	31	X	X	X	2	X	Aux.	Aux.	X	X	X	31	31	31	31	31	31	6	Aux.	Aux.	Aux.	Aux.	Aux.	Aux.	31	31	X	X	X	X	1*	Aux.	Aux.	X	X	X	X	Parameter Setting		ACS510 Relay Assignment						1	4	0	1	2	3	7	Autochange Enabled						1	4	0	1	2	3	7	RO1	RO2	RO3	RO4	RO5	RO6	31	31	X	X	X	X	1	PFC	PFC	X	X	X	X	31	31	31	X	X	X	2	PFC	PFC	PFC	X	X	X	X	31	31	X	X	X	1	X	PFC	PFC	X	X	X	31	31	31	31	31	31	5	PFC	PFC	PFC	PFC	PFC	PFC	31	31	X	X	X	X	0**	PFC	PFC	X	X	X	X
Parameter Setting		ACS510 Relay Assignment																																																																																																																																																																																																																		
1	4	0	1	2	3	7	Autochange Disabled																																																																																																																																																																																																													
1	4	0	1	2	3	7	RO1	RO2	RO3	RO4	RO5	RO6																																																																																																																																																																																																								
31	X	X	X	X	X	1	Aux.	X	X	X	X	X																																																																																																																																																																																																								
31	31	X	X	X	X	2	Aux.	Aux.	X	X	X	X																																																																																																																																																																																																								
31	31	31	X	X	X	3	Aux.	Aux.	Aux.	X	X	X																																																																																																																																																																																																								
X	31	31	X	X	X	2	X	Aux.	Aux.	X	X	X																																																																																																																																																																																																								
31	31	31	31	31	31	6	Aux.	Aux.	Aux.	Aux.	Aux.	Aux.																																																																																																																																																																																																								
31	31	X	X	X	X	1*	Aux.	Aux.	X	X	X	X																																																																																																																																																																																																								
Parameter Setting		ACS510 Relay Assignment																																																																																																																																																																																																																		
1	4	0	1	2	3	7	Autochange Enabled																																																																																																																																																																																																													
1	4	0	1	2	3	7	RO1	RO2	RO3	RO4	RO5	RO6																																																																																																																																																																																																								
31	31	X	X	X	X	1	PFC	PFC	X	X	X	X																																																																																																																																																																																																								
31	31	31	X	X	X	2	PFC	PFC	PFC	X	X	X																																																																																																																																																																																																								
X	31	31	X	X	X	1	X	PFC	PFC	X	X	X																																																																																																																																																																																																								
31	31	31	31	31	31	5	PFC	PFC	PFC	PFC	PFC	PFC																																																																																																																																																																																																								
31	31	X	X	X	X	0**	PFC	PFC	X	X	X	X																																																																																																																																																																																																								
8118	<p>AUTOCHNG INTERV</p> <p>Controls operation of the Autochange function and sets the interval between changes.</p> <ul style="list-style-type: none"> The Autochange time interval only applies to the time when the speed regulated motor is running. See parameter 8119 AUTOCHNG LEVEL for an overview of the Autochange function. The drive always coasts to a stop when autochange is performed. Autochange enabled requires parameter 8120 INTERLOCKS = value > 0. <p>0.0 = NOT SEL – Disables the Autochange function. 0.1...336 – The operating time interval (the time when the start signal is on) between automatic motor changes. -0.1 = TEST MODE – Forces the interval to value 36...48 s.</p> <p>Warning! When enabled, the Autochange function requires the interlocks (8120 interlocks = value > 0) enabled. During autochange the interlocks interrupt the drive's power output, preventing damage to the contacts.</p>																																																																																																																																																																																																																			
	<p style="text-align: center;">PFC with Autochange mode</p>																																																																																																																																																																																																																			

Code	Description
8119	<p>AUTOCHNG LEVEL</p> <p>Sets an upper limit, as a percent of output capacity, for the autochange logic. When the output from the PID/PFC control block exceeds this limit, autochange is prevented. For example, use this parameter to deny autochange when the Pump-Fan system is operating near maximum capacity.</p> <p>Autochange Overview</p> <p>The purpose of the autochange operation is to equalize duty time between multiple motors used in a system. At each autochange operation:</p> <ul style="list-style-type: none"> • A different motor takes a turn connected to the ACS510 output – the speed regulated motor. • The starting order of the other motors rotates. <p>The Autochange function requires:</p> <ul style="list-style-type: none"> • External switchgear for changing the drive's output power connections. • Parameter 8120 INTERLOCKS = value > 0. <p>Autochange is performed when:</p> <ul style="list-style-type: none"> • The running time since the previous autochange reaches the time set by 8118 AUTOCHNG INTERV • The PFC input is below the level set by this parameter, 8119 AUTOCHNG LEVEL. <p>Note! The ACS510 always coasts to stop when autochange is performed.</p> <p>In an autochange, the Autochange function does all of the following (see figure):</p> <ul style="list-style-type: none"> • Initiates a change when the running time, since the last autochange, reaches 8118 AUTOCHNG INTERV, and PFC input is below limit 8119 AUTOCHNG LEVEL. • Stops the speed regulated motor. • Switches off the contactor of the speed regulated motor. • Increments the starting order counter, to change the starting order for the motors. • Identifies the next motor in line to be the speed regulated motor. • Switches off the above motor's contactor, if the motor was running. Any other running motors are not interrupted. • Switches on the contactor of the new speed regulated motor. The autochange switchgear connects this motor to the ACS510 power output. • Delays motor start for the time 8122 PFC START DELAY. • Starts the speed regulated motor. • Identifies the next constant speed motor in the rotation. • Switches the above motor on, but only if the new speed regulated motor had been running (as a constant speed motor) – This step keeps an equal number of motors running before and after autochange. • Continues with normal PFC operation. <p>Starting Order Counter</p> <p>The operation of the starting-order counter:</p> <ul style="list-style-type: none"> • The relay output parameter definitions (1401...1403 and 1410...1412) establish the initial motor sequence. (The lowest parameter number with a value 31 (PFC) identifies the relay connected to 1PFC, the first motor, and so on.) • Initially, 1PFC = speed regulated motor, 2PFC = 1st auxiliary motor, etc. • The first autochange shifts the sequence to: 2PFC = speed regulated motor, 3PFC = 1st auxiliary motor, ..., 1PFC = last auxiliary motor. • The next autochange shifts the sequence again, and so on. • If the autochange cannot start a needed motor because all inactive motors are interlocked, the drive displays an alarm (2015, PFC INTERLOCK). • When ACS510 power supply is switched off, the counter preserves the current Autochange rotation positions in permanent memory. When power is restored, the Autochange rotation starts at the position stored in memory. • If the PFC relay configuration is changed (or if the PFC enable value is changed), the rotation is reset. (See the first bullet above.)

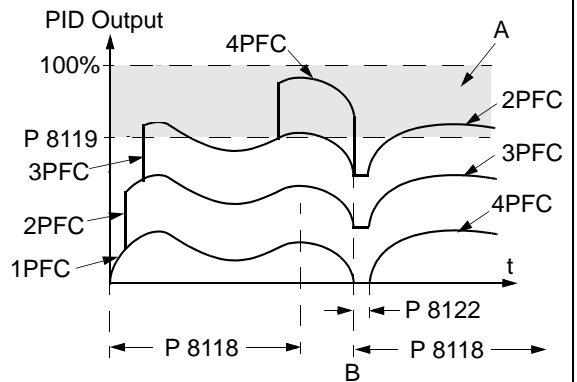

A = Area above 8119 AUTOCHNG LEVEL – autochange not allowed.
 B = Autochange occurs.
 1PFC, etc. = PID output associated with each motor.

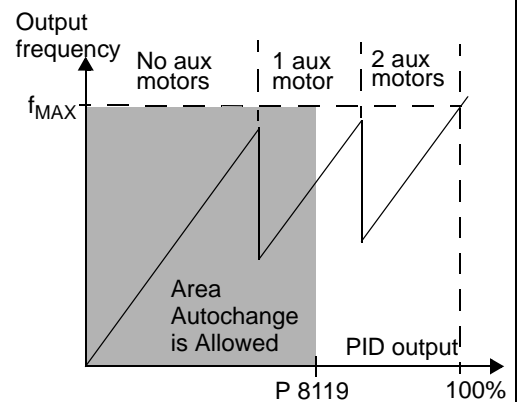

Code	Description																								
8120	<p>INTERLOCKS</p> <p>Defines operation of the Interlock function. When the Interlock function is enabled:</p> <ul style="list-style-type: none"> • An interlock is active when its command signal is absent. • An interlock is inactive when its command signal is present. • The ACS510 will not start if a start command occurs when the speed regulated motor's interlock is active – the control panel displays an alarm (2015, PFC I LOCK). <p>Wire each Interlock circuit as follows:</p> <ul style="list-style-type: none"> • Wire a contact of the motor's On/Off switch to the Interlock circuit – the drive's PFC logic can then recognize that the motor is switched off, and start the next available motor. • Wire a contact of the motor thermal relay (or other protective device in the motor circuit) to the Interlock input – the drive's PFC logic can then recognize that a motor fault is activated and stop the motor. <p>0 = NOT SEL – Disables the Interlock function. All digital inputs are available for other purposes.</p> <ul style="list-style-type: none"> • Requires 8118 AUTOCHNG INTERV = 0 (The Autochange function must be disabled if Interlock function is disabled.) <p>1 = DI1 – Enables the Interlock function, and assigns a digital input (starting with DI1) to the interlock signal for each PFC relay. These assignments are defined in the following table and depend on:</p> <ul style="list-style-type: none"> • The number of PFC relays (number of parameters 1401...1403 and 1410...1412) and with value = 31 PFC) • The Autochange function status (disabled if 8118 AUTOCHNG INTERV = 0, and otherwise enabled). <table border="1" style="width: 100%; border-collapse: collapse;"> <thead> <tr> <th style="background-color: #d3d3d3;">No. PFC Relays</th> <th style="background-color: #d3d3d3;">Autochange Disabled (P 8118)</th> <th style="background-color: #d3d3d3;">Autochange Enabled (P 8118)</th> </tr> </thead> <tbody> <tr> <td style="text-align: center;">0</td> <td>DI1: Speed Reg Motor DI2...DI6: Free</td> <td>Not allowed</td> </tr> <tr> <td style="text-align: center;">1</td> <td>DI1: Speed Reg Motor DI2: First PFC Relay DI3...DI6: Free</td> <td>DI1: First PFC Relay DI2...DI6: Free</td> </tr> <tr> <td style="text-align: center;">2</td> <td>DI1: Speed Reg Motor DI2: First PFC Relay DI3: Second PFC Relay DI4...DI6: Free</td> <td>DI1: First PFC Relay DI2: Second PFC Relay DI3...DI6: Free</td> </tr> <tr> <td style="text-align: center;">3</td> <td>DI1: Speed Reg Motor DI2: First PFC Relay DI3: Second PFC Relay DI4: Third PFC Relay DI5...DI6: Free</td> <td>DI1: First PFC Relay DI2: Second PFC Relay DI3: Third PFC Relay DI4...DI6: Free</td> </tr> <tr> <td style="text-align: center;">4</td> <td>DI1: Speed Reg Motor DI2: First PFC Relay DI3: Second PFC Relay DI4: Third PFC Relay DI5: Fourth PFC Relay DI6: Free</td> <td>DI1: First PFC Relay DI2: Second PFC Relay DI3: Third PFC Relay DI4: Fourth PFC Relay DI5...DI6: Free</td> </tr> <tr> <td style="text-align: center;">5</td> <td>DI1: Speed Reg Motor DI2: First PFC Relay DI3: Second PFC Relay DI4: Third PFC Relay DI5: Fourth PFC Relay DI6: Fifth PFC Relay</td> <td>DI1: First PFC Relay DI2: Second PFC Relay DI3: Third PFC Relay DI4: Fourth PFC Relay DI5: Fifth PFC Relay DI6: Free</td> </tr> <tr> <td style="text-align: center;">6</td> <td>Not allowed</td> <td>DI1: First PFC Relay DI2: Second PFC Relay DI3: Third PFC Relay DI4: Fourth PFC Relay DI5: Fifth PFC Relay DI6: Sixth PFC Relay</td> </tr> </tbody> </table>	No. PFC Relays	Autochange Disabled (P 8118)	Autochange Enabled (P 8118)	0	DI1: Speed Reg Motor DI2...DI6: Free	Not allowed	1	DI1: Speed Reg Motor DI2: First PFC Relay DI3...DI6: Free	DI1: First PFC Relay DI2...DI6: Free	2	DI1: Speed Reg Motor DI2: First PFC Relay DI3: Second PFC Relay DI4...DI6: Free	DI1: First PFC Relay DI2: Second PFC Relay DI3...DI6: Free	3	DI1: Speed Reg Motor DI2: First PFC Relay DI3: Second PFC Relay DI4: Third PFC Relay DI5...DI6: Free	DI1: First PFC Relay DI2: Second PFC Relay DI3: Third PFC Relay DI4...DI6: Free	4	DI1: Speed Reg Motor DI2: First PFC Relay DI3: Second PFC Relay DI4: Third PFC Relay DI5: Fourth PFC Relay DI6: Free	DI1: First PFC Relay DI2: Second PFC Relay DI3: Third PFC Relay DI4: Fourth PFC Relay DI5...DI6: Free	5	DI1: Speed Reg Motor DI2: First PFC Relay DI3: Second PFC Relay DI4: Third PFC Relay DI5: Fourth PFC Relay DI6: Fifth PFC Relay	DI1: First PFC Relay DI2: Second PFC Relay DI3: Third PFC Relay DI4: Fourth PFC Relay DI5: Fifth PFC Relay DI6: Free	6	Not allowed	DI1: First PFC Relay DI2: Second PFC Relay DI3: Third PFC Relay DI4: Fourth PFC Relay DI5: Fifth PFC Relay DI6: Sixth PFC Relay
No. PFC Relays	Autochange Disabled (P 8118)	Autochange Enabled (P 8118)																							
0	DI1: Speed Reg Motor DI2...DI6: Free	Not allowed																							
1	DI1: Speed Reg Motor DI2: First PFC Relay DI3...DI6: Free	DI1: First PFC Relay DI2...DI6: Free																							
2	DI1: Speed Reg Motor DI2: First PFC Relay DI3: Second PFC Relay DI4...DI6: Free	DI1: First PFC Relay DI2: Second PFC Relay DI3...DI6: Free																							
3	DI1: Speed Reg Motor DI2: First PFC Relay DI3: Second PFC Relay DI4: Third PFC Relay DI5...DI6: Free	DI1: First PFC Relay DI2: Second PFC Relay DI3: Third PFC Relay DI4...DI6: Free																							
4	DI1: Speed Reg Motor DI2: First PFC Relay DI3: Second PFC Relay DI4: Third PFC Relay DI5: Fourth PFC Relay DI6: Free	DI1: First PFC Relay DI2: Second PFC Relay DI3: Third PFC Relay DI4: Fourth PFC Relay DI5...DI6: Free																							
5	DI1: Speed Reg Motor DI2: First PFC Relay DI3: Second PFC Relay DI4: Third PFC Relay DI5: Fourth PFC Relay DI6: Fifth PFC Relay	DI1: First PFC Relay DI2: Second PFC Relay DI3: Third PFC Relay DI4: Fourth PFC Relay DI5: Fifth PFC Relay DI6: Free																							
6	Not allowed	DI1: First PFC Relay DI2: Second PFC Relay DI3: Third PFC Relay DI4: Fourth PFC Relay DI5: Fifth PFC Relay DI6: Sixth PFC Relay																							

Code	Description																								
	<p>2 = DI2 – Enables the Interlock function, and assigns a digital input (starting with DI2) to the interlock signal for each PFC relay. These assignments are defined in the following table and depend on:</p> <ul style="list-style-type: none"> • The number of PFC relays (number of parameters 1401...1403 and 1410...1412) with value = 31 PFC) • The Autochange function status (disabled if 8118 AUTOCHNG INTERV = 0, and otherwise enabled). 																								
	<table border="1"> <thead> <tr> <th>No. PFC Relays</th> <th>Autochange Disabled (P 8118)</th> <th>Autochange Enabled (P 8118)</th> </tr> </thead> <tbody> <tr> <td>0</td> <td>DI1: Free DI2: Speed Reg Motor DI3...DI6: Free</td> <td>Not allowed</td> </tr> <tr> <td>1</td> <td>DI1: Free DI2: Speed Reg Motor DI3: First PFC Relay DI4...DI6: Free</td> <td>DI1: Free DI2: First PFC Relay DI3...DI6: Free</td> </tr> <tr> <td>2</td> <td>DI1: Free DI2: Speed Reg Motor DI3: First PFC Relay DI4: Second PFC Relay DI5...DI6: Free</td> <td>DI1: Free DI2: First PFC Relay DI3: Second PFC Relay DI4...DI6: Free</td> </tr> <tr> <td>3</td> <td>DI1: Free DI2: Speed Reg Motor DI3: First PFC Relay DI4: Second PFC Relay DI5: Third PFC Relay DI6: Free</td> <td>DI1: Free DI2: First PFC Relay DI3: Second PFC Relay DI4: Third PFC Relay DI5...DI6: Free</td> </tr> <tr> <td>4</td> <td>DI1: Free DI2: Speed Reg Motor DI3: First PFC Relay DI4: Second PFC Relay DI5: Third PFC Relay DI6: Fourth PFC Relay</td> <td>DI1: Free DI2: First PFC Relay DI3: Second PFC Relay DI4: Third PFC Relay DI5: Fourth PFC Relay DI6: Free</td> </tr> <tr> <td>5</td> <td>Not allowed</td> <td>DI1: Free DI2: First PFC Relay DI3: Second PFC Relay DI4: Third PFC Relay DI5: Fourth PFC Relay DI6: Fifth PFC Relay</td> </tr> <tr> <td>6</td> <td>Not allowed</td> <td>Not allowed</td> </tr> </tbody> </table>	No. PFC Relays	Autochange Disabled (P 8118)	Autochange Enabled (P 8118)	0	DI1: Free DI2: Speed Reg Motor DI3...DI6: Free	Not allowed	1	DI1: Free DI2: Speed Reg Motor DI3: First PFC Relay DI4...DI6: Free	DI1: Free DI2: First PFC Relay DI3...DI6: Free	2	DI1: Free DI2: Speed Reg Motor DI3: First PFC Relay DI4: Second PFC Relay DI5...DI6: Free	DI1: Free DI2: First PFC Relay DI3: Second PFC Relay DI4...DI6: Free	3	DI1: Free DI2: Speed Reg Motor DI3: First PFC Relay DI4: Second PFC Relay DI5: Third PFC Relay DI6: Free	DI1: Free DI2: First PFC Relay DI3: Second PFC Relay DI4: Third PFC Relay DI5...DI6: Free	4	DI1: Free DI2: Speed Reg Motor DI3: First PFC Relay DI4: Second PFC Relay DI5: Third PFC Relay DI6: Fourth PFC Relay	DI1: Free DI2: First PFC Relay DI3: Second PFC Relay DI4: Third PFC Relay DI5: Fourth PFC Relay DI6: Free	5	Not allowed	DI1: Free DI2: First PFC Relay DI3: Second PFC Relay DI4: Third PFC Relay DI5: Fourth PFC Relay DI6: Fifth PFC Relay	6	Not allowed	Not allowed
No. PFC Relays	Autochange Disabled (P 8118)	Autochange Enabled (P 8118)																							
0	DI1: Free DI2: Speed Reg Motor DI3...DI6: Free	Not allowed																							
1	DI1: Free DI2: Speed Reg Motor DI3: First PFC Relay DI4...DI6: Free	DI1: Free DI2: First PFC Relay DI3...DI6: Free																							
2	DI1: Free DI2: Speed Reg Motor DI3: First PFC Relay DI4: Second PFC Relay DI5...DI6: Free	DI1: Free DI2: First PFC Relay DI3: Second PFC Relay DI4...DI6: Free																							
3	DI1: Free DI2: Speed Reg Motor DI3: First PFC Relay DI4: Second PFC Relay DI5: Third PFC Relay DI6: Free	DI1: Free DI2: First PFC Relay DI3: Second PFC Relay DI4: Third PFC Relay DI5...DI6: Free																							
4	DI1: Free DI2: Speed Reg Motor DI3: First PFC Relay DI4: Second PFC Relay DI5: Third PFC Relay DI6: Fourth PFC Relay	DI1: Free DI2: First PFC Relay DI3: Second PFC Relay DI4: Third PFC Relay DI5: Fourth PFC Relay DI6: Free																							
5	Not allowed	DI1: Free DI2: First PFC Relay DI3: Second PFC Relay DI4: Third PFC Relay DI5: Fourth PFC Relay DI6: Fifth PFC Relay																							
6	Not allowed	Not allowed																							

Code	Description																																							
	<p>3 = DI3 – Enables the Interlocks function, and assigns a digital input (starting with DI3) to the interlock signal for each PFC relay. These assignments are defined in the following table and depend on:</p> <ul style="list-style-type: none"> • The number of PFC relays (number of parameters 1401...1403 and 1410...1412) with value = 31 PFC) • The Autochange function status (disabled if 8118 AUTOCHNG INTERV = 0, and otherwise enabled). <table border="1"> <thead> <tr> <th>No. PFC Relays</th> <th>Autochange Disabled (P 8118)</th> <th>Autochange Enabled (P 8118)</th> </tr> </thead> <tbody> <tr> <td>0</td> <td>DI1...DI2: Free DI3: Speed Reg Motor DI4...DI6: Free</td> <td>Not allowed</td> </tr> <tr> <td>1</td> <td>DI1...DI2: Free DI3: Speed Reg Motor DI4: First PFC Relay DI5...DI6: Free</td> <td>DI1...DI2: Free DI3: First PFC Relay DI4...DI6: Free</td> </tr> <tr> <td>2</td> <td>DI1...DI2: Free DI3: Speed Reg Motor DI4: First PFC Relay DI5: Second PFC Relay DI6: Free</td> <td>DI1...DI2: Free DI3: First PFC Relay DI4: Second PFC Relay DI5...DI6: Free</td> </tr> <tr> <td>3</td> <td>DI1...DI2: Free DI3: Speed Reg Motor DI4: First PFC Relay DI5: Second PFC Relay DI6: Third PFC Relay</td> <td>DI1...DI2: Free DI3: First PFC Relay DI4: Second PFC Relay DI5: Third PFC Relay DI6: Free</td> </tr> <tr> <td>4</td> <td>Not allowed</td> <td>DI1...DI2: Free DI3: First PFC Relay DI4: Second PFC Relay DI5: Third PFC Relay DI6: Fourth PFC Relay</td> </tr> <tr> <td>5...6</td> <td>Not allowed</td> <td>Not allowed</td> </tr> </tbody> </table> <p>4 = DI4 – Enables the Interlock function, and assigns a digital input (starting with DI4) to the interlock signal for each PFC relay. These assignments are defined in the following table and depend on:</p> <ul style="list-style-type: none"> • The number of PFC relays (number of parameters 1401...1403 and 1410...1412) with value = 31 PFC) • The Autochange function status (disabled if 8118 AUTOCHNG INTERV = 0, and otherwise enabled). <table border="1"> <thead> <tr> <th>No. PFC Relays</th> <th>Autochange Disabled (P 8118)</th> <th>Autochange Enabled (P 8118)</th> </tr> </thead> <tbody> <tr> <td>0</td> <td>DI1...DI3: Free DI4: Speed Reg Motor DI5...DI6: Free</td> <td>Not allowed</td> </tr> <tr> <td>1</td> <td>DI1...DI3: Free DI4: Speed Reg Motor DI5: First PFC Relay DI6: Free</td> <td>DI1...DI3: Free DI4: First PFC Relay DI5...DI6: Free</td> </tr> <tr> <td>2</td> <td>DI1...DI3: Free DI4: Speed Reg Motor DI5: First PFC Relay DI6: Second PFC Relay</td> <td>DI1...DI3: Free DI4: First PFC Relay DI5: Second PFC Relay DI6: Free</td> </tr> <tr> <td>3</td> <td>Not allowed</td> <td>DI1...DI3: Free DI4: First PFC Relay DI5: Second PFC Relay DI6: Third PFC Relay</td> </tr> <tr> <td>4...6</td> <td>Not allowed</td> <td>Not allowed</td> </tr> </tbody> </table>	No. PFC Relays	Autochange Disabled (P 8118)	Autochange Enabled (P 8118)	0	DI1...DI2: Free DI3: Speed Reg Motor DI4...DI6: Free	Not allowed	1	DI1...DI2: Free DI3: Speed Reg Motor DI4: First PFC Relay DI5...DI6: Free	DI1...DI2: Free DI3: First PFC Relay DI4...DI6: Free	2	DI1...DI2: Free DI3: Speed Reg Motor DI4: First PFC Relay DI5: Second PFC Relay DI6: Free	DI1...DI2: Free DI3: First PFC Relay DI4: Second PFC Relay DI5...DI6: Free	3	DI1...DI2: Free DI3: Speed Reg Motor DI4: First PFC Relay DI5: Second PFC Relay DI6: Third PFC Relay	DI1...DI2: Free DI3: First PFC Relay DI4: Second PFC Relay DI5: Third PFC Relay DI6: Free	4	Not allowed	DI1...DI2: Free DI3: First PFC Relay DI4: Second PFC Relay DI5: Third PFC Relay DI6: Fourth PFC Relay	5...6	Not allowed	Not allowed	No. PFC Relays	Autochange Disabled (P 8118)	Autochange Enabled (P 8118)	0	DI1...DI3: Free DI4: Speed Reg Motor DI5...DI6: Free	Not allowed	1	DI1...DI3: Free DI4: Speed Reg Motor DI5: First PFC Relay DI6: Free	DI1...DI3: Free DI4: First PFC Relay DI5...DI6: Free	2	DI1...DI3: Free DI4: Speed Reg Motor DI5: First PFC Relay DI6: Second PFC Relay	DI1...DI3: Free DI4: First PFC Relay DI5: Second PFC Relay DI6: Free	3	Not allowed	DI1...DI3: Free DI4: First PFC Relay DI5: Second PFC Relay DI6: Third PFC Relay	4...6	Not allowed	Not allowed
No. PFC Relays	Autochange Disabled (P 8118)	Autochange Enabled (P 8118)																																						
0	DI1...DI2: Free DI3: Speed Reg Motor DI4...DI6: Free	Not allowed																																						
1	DI1...DI2: Free DI3: Speed Reg Motor DI4: First PFC Relay DI5...DI6: Free	DI1...DI2: Free DI3: First PFC Relay DI4...DI6: Free																																						
2	DI1...DI2: Free DI3: Speed Reg Motor DI4: First PFC Relay DI5: Second PFC Relay DI6: Free	DI1...DI2: Free DI3: First PFC Relay DI4: Second PFC Relay DI5...DI6: Free																																						
3	DI1...DI2: Free DI3: Speed Reg Motor DI4: First PFC Relay DI5: Second PFC Relay DI6: Third PFC Relay	DI1...DI2: Free DI3: First PFC Relay DI4: Second PFC Relay DI5: Third PFC Relay DI6: Free																																						
4	Not allowed	DI1...DI2: Free DI3: First PFC Relay DI4: Second PFC Relay DI5: Third PFC Relay DI6: Fourth PFC Relay																																						
5...6	Not allowed	Not allowed																																						
No. PFC Relays	Autochange Disabled (P 8118)	Autochange Enabled (P 8118)																																						
0	DI1...DI3: Free DI4: Speed Reg Motor DI5...DI6: Free	Not allowed																																						
1	DI1...DI3: Free DI4: Speed Reg Motor DI5: First PFC Relay DI6: Free	DI1...DI3: Free DI4: First PFC Relay DI5...DI6: Free																																						
2	DI1...DI3: Free DI4: Speed Reg Motor DI5: First PFC Relay DI6: Second PFC Relay	DI1...DI3: Free DI4: First PFC Relay DI5: Second PFC Relay DI6: Free																																						
3	Not allowed	DI1...DI3: Free DI4: First PFC Relay DI5: Second PFC Relay DI6: Third PFC Relay																																						
4...6	Not allowed	Not allowed																																						

Code	Description																											
5	<p>= DI5 – Enables the Interlock function, and assigns a digital input (starting with DI5) to the interlock signal for each PFC relay. These assignments are defined in the following table and depend on:</p> <ul style="list-style-type: none"> • The number of PFC relays (number of parameters 1401...1403 and 1410...1412) with value = 31 PFC) • The Autochange function status (disabled if 8118 AUTOCHNG INTERV = 0, and otherwise enabled). <table border="1"> <thead> <tr> <th>No. PFC Relays</th> <th>Autochange Disabled (P 8118)</th> <th>Autochange Enabled (P 8118)</th> </tr> </thead> <tbody> <tr> <td>0</td> <td>DI1...DI4: Free DI5: Speed Reg Motor DI6: Free</td> <td>Not allowed</td> </tr> <tr> <td>1</td> <td>DI1...DI4: Free DI5: Speed Reg Motor DI6: First PFC Relay</td> <td>DI1...DI4: Free DI5: First PFC Relay DI6: Free</td> </tr> <tr> <td>2</td> <td>Not allowed</td> <td>DI1...DI4: Free DI5: First PFC Relay DI6: Second PFC Relay</td> </tr> <tr> <td>3...6</td> <td>Not allowed</td> <td>Not allowed</td> </tr> </tbody> </table> <p>6 = DI6 – Enables the Interlock function, and assigns digital input DI6 to the interlock signal for the speed regulated motor.</p> <ul style="list-style-type: none"> • Requires 8118 AUTOCHNG INTERV = 0. <table border="1"> <thead> <tr> <th>No. PFC Relays</th> <th>Autochange Disabled</th> <th>Autochange Enabled</th> </tr> </thead> <tbody> <tr> <td>0</td> <td>DI1...DI5: Free DI6: Speed Reg Motor</td> <td>Not allowed</td> </tr> <tr> <td>1</td> <td>Not allowed</td> <td>DI1...DI5: Free DI6: First PFC Relay</td> </tr> <tr> <td>2...6</td> <td>Not allowed</td> <td>Not allowed</td> </tr> </tbody> </table>	No. PFC Relays	Autochange Disabled (P 8118)	Autochange Enabled (P 8118)	0	DI1...DI4: Free DI5: Speed Reg Motor DI6: Free	Not allowed	1	DI1...DI4: Free DI5: Speed Reg Motor DI6: First PFC Relay	DI1...DI4: Free DI5: First PFC Relay DI6: Free	2	Not allowed	DI1...DI4: Free DI5: First PFC Relay DI6: Second PFC Relay	3...6	Not allowed	Not allowed	No. PFC Relays	Autochange Disabled	Autochange Enabled	0	DI1...DI5: Free DI6: Speed Reg Motor	Not allowed	1	Not allowed	DI1...DI5: Free DI6: First PFC Relay	2...6	Not allowed	Not allowed
No. PFC Relays	Autochange Disabled (P 8118)	Autochange Enabled (P 8118)																										
0	DI1...DI4: Free DI5: Speed Reg Motor DI6: Free	Not allowed																										
1	DI1...DI4: Free DI5: Speed Reg Motor DI6: First PFC Relay	DI1...DI4: Free DI5: First PFC Relay DI6: Free																										
2	Not allowed	DI1...DI4: Free DI5: First PFC Relay DI6: Second PFC Relay																										
3...6	Not allowed	Not allowed																										
No. PFC Relays	Autochange Disabled	Autochange Enabled																										
0	DI1...DI5: Free DI6: Speed Reg Motor	Not allowed																										
1	Not allowed	DI1...DI5: Free DI6: First PFC Relay																										
2...6	Not allowed	Not allowed																										

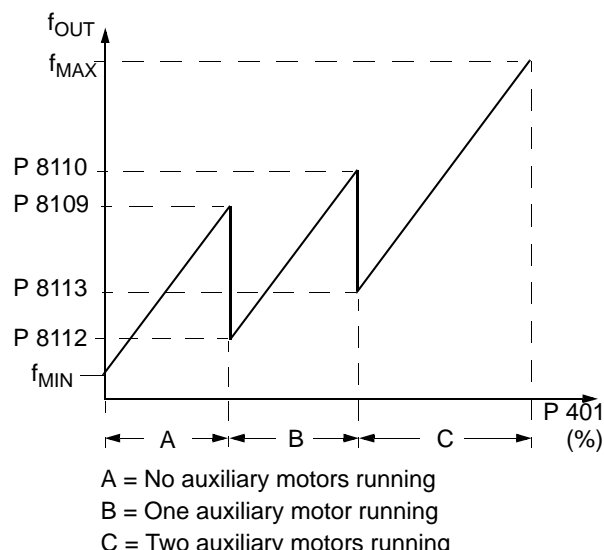
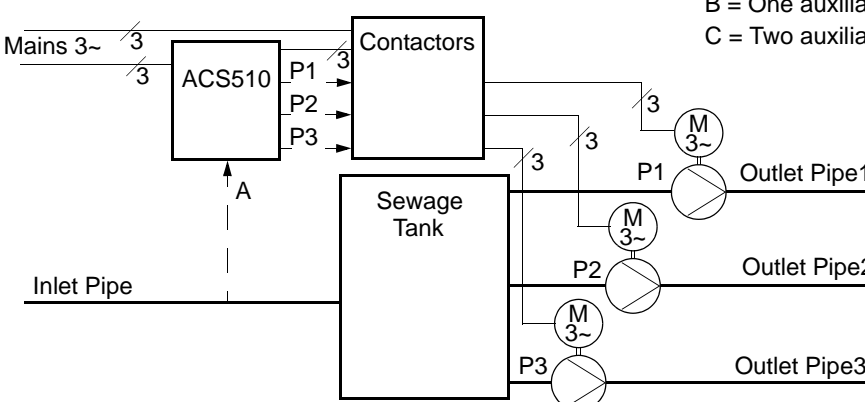
Code	Description
8121	<p>REG BYPASS CTRL</p> <p>Selects Regulator by-pass control. When enabled, Regulator by-pass control provides a simple control mechanism without a PID regulator.</p> <p>Use Regulator by-pass control only in special applications.</p> <p>0 = NO – Disables Regulator by-pass control. The drive uses the normal PFC reference: 1106 REF2 SELECT.</p> <p>1 = YES – Enables Regulator by-pass control.</p> <ul style="list-style-type: none"> • The process PID regulator is bypassed. Actual value of PID is used as the PFC reference (input). Normally EXT REF2 is used as the PFC reference. • The drive uses the feedback signal defined by 4014 FBK SEL (or 4114) for the PFC frequency reference. • The figure shows the relation between the control signal 4014 FBK SEL (OR 4114) and the speed regulated motor's frequency in a three-motor system. <p>Example: In the diagram below, the pumping station's outlet flow is controlled by the measured inlet flow (A).</p>  
8122	<p>PFC START DELAY</p> <p>Sets the start delay for speed regulated motors in the system. Using the delay, the drive works as follows:</p> <ul style="list-style-type: none"> • Switches on the contactor of the speed regulated motor – connecting the motor to the ACS510 power output. • Delays motor start for the time 8122 PFC START DELAY. • Starts the speed regulated motor. • Starts auxiliary motors. See parameter 8115 for delay. <p>Warning! Motors equipped with star-delta starters require a PFC Start Delay.</p> <ul style="list-style-type: none"> • After the ACS510 relay output switches a motor On, the star-delta starter must switch to the star-connection and then back to the delta-connection before the drive applies power. • So, the PFC Start Delay must be longer than the time setting of the star-delta starter.
8123	<p>PFC ENABLE</p> <p>Selects PFC control. When enabled, PFC control:</p> <ul style="list-style-type: none"> • Switches in, or out, auxiliary constant speed motors as output demand increases or decreases. Parameters 8109 START FREQ 1 to 8114 LOW FREQ 3 define the switch points in terms of the drive output frequency. • Adjusts the speed regulated motor output down, as auxiliary motors are added, and adjusts the speed regulated motor output up, as auxiliary motors are taken off line. • Provides Interlock functions, if enabled. <p>0 = NOT SEL – Disables PFC control.</p> <p>1 = ACTIVE – Enables PFC control.</p> <p>2 = CYCLE SOFT START – Enables PFC control and use cycle soft-start function.</p> <ul style="list-style-type: none"> • Require parameter 8118 = value > 0 .

Code	Description	
8124	<p>ACC IN AUX STOP</p> <p>Sets the PFC acceleration time for a zero-to-maximum frequency ramp. This PFC acceleration ramp:</p> <ul style="list-style-type: none"> • Applies to the speed regulated motor, when an auxiliary motor is switched off. • Replaces the acceleration ramp defined in Group 22: Accel / Decel. • Applies only until the output of the regulated motor increases by an amount equal to the output of the switched off auxiliary motor. Then the acceleration ramp defined in Group 22: Accel / Decel applies. <p>0 = NOT SEL. 0.1...1800 = Activates this function using the value entered as the acceleration time.</p>	<p>The figure consists of two vertically aligned graphs sharing a common time axis 't'. The top graph plots output frequency 'f_{OUT}' against time. It shows a speed regulated motor's frequency response. Point 'A' marks the start of an acceleration ramp. Point 'B' marks the start of a deceleration ramp. A third ramp, labeled 'P 8124', occurs when the auxiliary motor stops. The bottom graph plots the auxiliary motor's state (0 or 1) against time. A pulse labeled 'P 8125' indicates the auxiliary motor's start and stop times, which correspond to the acceleration and deceleration events in the top graph.</p>
8125	<p>DEC IN AUX START</p> <p>Sets the PFC deceleration time for a maximum-to-zero frequency ramp. This PFC deceleration ramp:</p> <ul style="list-style-type: none"> • Applies to the speed regulated motor, when an auxiliary motor is switched on. • Replaces the deceleration ramp defined in Group 22 ACCEL / DECEL. • Applies only until the output of the regulated motor decreases by an amount equal to the output of the auxiliary motor. Then the deceleration ramp defined in Group 22 ACCEL / DECEL applies. <p>0 = NOT SEL. 0.1...1800 = Activates this function using the value entered as the deceleration time.</p>	
8127	<p>MOTORS</p> <p>Sets the actual number of PFC controlled motors (maximum 7 motors, 1 speed regulated + 6 connected direct-on-line motors, or 1 speed regulated + 3 connected direct-on-line and 3 spare motors).</p> <ul style="list-style-type: none"> • This value includes also the speed regulated motor. • This value must be compatible with number of relays allocated to PFC if the autochange function is used. • If Autochange function is not used, the speed regulated motor does not need to have a relay output allocated to PFC but it needs to be included in this value. 	
8128	<p>AUX START ORDER</p> <p>Sets the start order of the auxiliary motors.</p> <p>1 = EVEN RUNTIME – Time sharing is active. The start order depends on the run times. 2 = RELAY ORDER – The start order is fixed to be the order of the relays.</p>	

Group 98: Options

This group configures for options, in particular, enabling serial communication with the drive.

Code	Description
9802	COMM PROT SEL Selects the communication protocol. 0 = NOT SEL – No communication protocol selected. 1 = STD MODBUS – The drive communicates with Modbus via the RS485 channel (X1-communications, terminal). <ul style="list-style-type: none">• See also parameter Group 53 EFB PROTOCOL. 4 = EXT FBA – The drive communicates via a fieldbus adapter module in option slot 2 of the drive. <ul style="list-style-type: none">• See also parameter Group 51 EXT COMM MODULE.

Embedded Fieldbus

Overview

The ACS510 can be set up to accept control from an external system using standard serial communication protocols. When using serial communication, the ACS510 can either:

- Receive all of its control information from the fieldbus, or
- Be controlled from some combination of fieldbus control and other available control locations, such as digital or analog inputs, and the control panel.

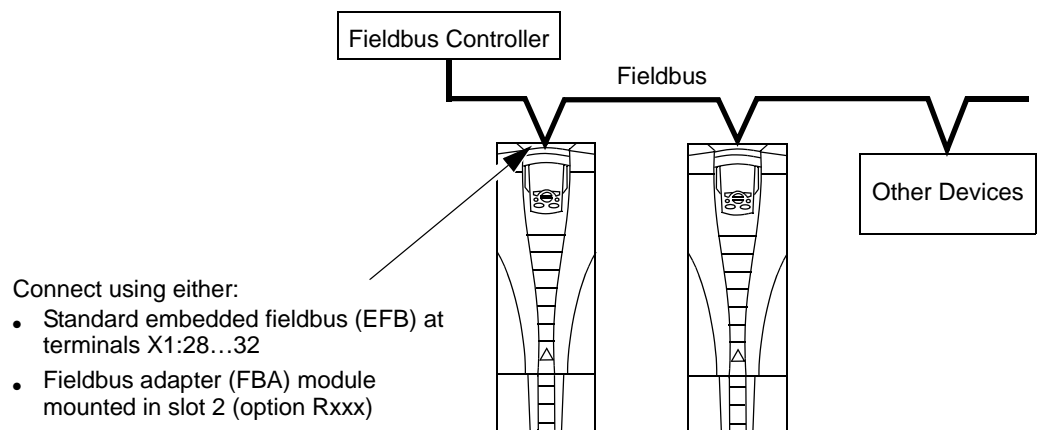

Two basic serial communications configurations are available:

- Embedded fieldbus (EFB) – Using the RS485 interface at terminals X1:28...32 on the control board, a control system can communicate with the drive using the Modbus® protocol. (For protocol and profile descriptions, see "Modbus Protocol Technical Data" and "ABB Control Profiles Technical Data" later in this section.)
- Fieldbus adapter (FBA) – See "Fieldbus Adapter" on page 175.

Control Interface

In general, the basic control interface between Modbus and the drive consists of:

- Output words
 - Control Word
 - Reference1
 - Reference2
- Input words
 - Status Word
 - Actual value 1
 - Actual value 2
 - Actual value 3

- Actual value 4
- Actual value 5
- Actual value 6
- Actual value 7
- Actual value 8

The content of these words is defined by profiles. For details on the profiles used, see "ABB Control Profiles Technical Data" on page 163.

Note! The words “output” and “input” are used as seen from the fieldbus controller point of view. For example an output describes data flow from the fieldbus controller to the drive and appears as an input from the drive point of view.

Planning

Network planning should address the following questions:

- What types and quantities of devices must be connected to the network?
- What control information must be sent down to the drives?
- What feedback information must be sent from the drives to the controlling system?

Mechanical and Electrical Installation – EFB



Warning! Connections should be made only while the drive is disconnected from the power source.

Drive terminals 28...32 are for RS485 communications.

- Use Belden 9842 or equivalent. Belden 9842 is a dual twisted, shielded pair cable with a wave impedance of 120 ohm.
- Use one of these twisted shielded pairs for the RS485 link. Use this pair to connect all A (-) terminals together and all B (+) terminals together.
- Use one of the wires in the other pair for the logical ground (terminal 31), leaving one wire unused.
- Do not directly ground the RS485 network at any point. Ground all devices on the network using their corresponding earthing terminals.
- As always, the grounding wires should not form any closed loops, and all the devices should be earthed to a common ground.
- Connect the RS485 link in a daisy-chained bus, without dropout lines.

- To reduce noise on the network, terminate the RS485 network using 120 Ω resistors at both ends of the network. Use the DIP switch to connect or disconnect the termination resistors. See following diagram and table.



X1	Identification	Hardware Description											
28	Screen	RS485 Multidrop application											
29	B (Positive +)		<table border="1"> <tr> <td>28</td> <td>SCR</td> </tr> <tr> <td>29</td> <td>B</td> </tr> <tr> <td>30</td> <td>A</td> </tr> <tr> <td>31</td> <td>AGND</td> </tr> <tr> <td>32</td> <td>SCR</td> </tr> </table>	28	SCR	29	B	30	A	31	AGND	32	SCR
28	SCR												
29	B												
30	A												
31	AGND												
32	SCR												
30	A (Negative -)												
31	AGND												
32	Screen		<table border="1"> <tr> <th colspan="2">RS485 interface</th> </tr> <tr> <td> </td> <td> </td> </tr> <tr> <td>OFF position</td> <td>ON position</td> </tr> <tr> <td colspan="2">Bus termination</td> </tr> </table>	RS485 interface				OFF position	ON position	Bus termination			
RS485 interface													
OFF position	ON position												
Bus termination													

- Connect the shield at each end of the cable to a drive. On one end, connect the shield to terminal 28, and on the other end connect to terminal 32. Do not connect the incoming and outgoing cable shields to the same terminals, as that would make the shielding continuous.
- For configuration information see the following:
 - "Communication Set-up – EFB" below.
 - "Activate Drive Control Functions – EFB" on page 147.
 - The appropriate EFB protocol specific technical data. For example, "Modbus Protocol Technical Data" on page 155.

Communication Set-up – EFB

Serial Communication Selection

To activate the serial communication, set parameter 9802 COMM PROT SEL = 1 (STD MODBUS).

Note! If you cannot see the desired selection on the panel, your drive does not have that protocol software in the application memory.

Serial Communication Configuration

Setting 9802 automatically sets the appropriate default values in parameters that define the communication process. These parameters and descriptions are defined below. In particular, note that the station Id may require adjustment.

Code	Description	Protocol Reference
		Modbus
5301	EFB PROTOCOL ID Contains the identification and program revision of the protocol.	Do not edit. Any non-zero value entered for parameter 9802 COMM PROT SEL, sets this parameter automatically. The format is: XXYY, where XX = protocol ID, and YY = program revision.
5302	EFB STATION ID Defines the node address of the RS485 link. Note! For a new address to take affect, the drive power must be cycled or 5302 must first be set to 0 before selecting a new address. Leaving 5302 = 0 places the RS485 channel in reset, disabling communication.	Set each drive on the network with a unique value for this parameter. When this protocol is selected, the default value for this parameter is: 1
5303	EFB BAUD RATE Defines the communication speed of the RS485 link in kbits per second (kbits/s). 1.2 kb/s 19.2 kb/s 2.4 kb/s 38.4 kb/s 4.8 kb/s 57.6 kb/s 9.6 kb/s 76.8 kb/s	When this protocol is selected, the default value for this parameter is: 9.6
5304	EFB PARITY Defines the data length, parity and stop bits to be used with the RS485 communication. The same settings must be used in all on-line stations. 0 = 8 NONE 1 – 8 data bits, no parity, one stop bit. 1 = 8 NONE 2 – 8 data bits, no parity, two stop bits. 2 = 8 EVEN 1 – 8 data bits, even parity, one stop bit. 3 = 8 ODD 1 – 8 data bits, Odd parity, one stop bit.	When this protocol is selected, the default value for this parameter is: 1
5305	EFB CTRL PROFILE Selects the communication profile used by the EFB protocol. 0 = ABB DRV LIM – Operation of Control/Status Words conforms to ABB Drives Profile, as used in ACS400. 1 = DCU PROFILE – Operation of Control/Status Words conforms to 32-bit DCU Profile. 2 = ABB DRV FULL – Operation of Control/Status Words conforms to ABB Drives Profile, as used in ACS600/800.	When this protocol is selected, the default value for this parameter is: 0

Note! After any changes to the communication settings, the protocol must be reactivated by either cycling the drive power, or by clearing and then restoring the station Id (5302).

Activate Drive Control Functions – EFB

Controlling the Drive

Fieldbus control of various drive functions requires configuration to:

- Tell the drive to accept fieldbus control of the function.
- Define as a fieldbus input, any drive data required for control.
- Define as a fieldbus output, any control data required by the drive.

The following sections describe, at a general level, the configuration required for each control function. For the protocol-specific details, see the document supplied with the FBA module.

Start/Stop Direction Control

Using the fieldbus for start/stop/direction control of the drive requires:

- Drive parameter values set as defined below.
- Fieldbus controller supplied command(s) in the appropriate location. (The location is defined by the Protocol Reference, which is protocol dependent.)

Drive Parameter		Value	Description	Modbus ¹ Protocol Reference	
				ABB DRV	DCU PROFILE
1001	EXT1 COMMANDS	10 (COMM)	Start/Stop by fieldbus with Ext1 selected.	40001 bits 0...3	40031 bits 0, 1
1002	EXT2 COMMANDS	10 (COMM)	Start/Stop by fieldbus with Ext2 selected.	40001 bits 0...3	40031 bits 0, 1
1003*	DIRECTION	3 (REQUEST)	Direction by fieldbus.	40002/40003 ²	40031 bit 3

* This parameter is not available in software option +N688 and +N689.

1. For Modbus, the protocol reference can depend on the profile used, hence two columns in these tables. One column refers to the ABB Drives profile, selected when parameter 5305 = 0 (ABB DRV LIM) or 5305 = 2 (ABB DRV FULL). The other column refers to the DCU profile selected when parameter 5305 = 1 (DCU PROFILE). See "ABB Control Profiles Technical Data" on page 163.
2. The reference provides direction control – a negative reference provides reverse rotation.

Input Reference Select

Using the fieldbus to provide input references to the drive requires:

- Drive parameter values set as defined below.
- Fieldbus controller supplied reference word(s) in the appropriate location. (The location is defined by the Protocol Reference, which is protocol dependent.)

Drive Parameter		Value	Description	Modbus Protocol Reference	
				ABB DRV	DCU PROFILE
1102	EXT1/EXT2 SEL	8 (COMM)	Reference set selection by fieldbus.	40001 bit 11	40031 bit 5
1103	REF1 SELECT	8 (COMM)	Input reference 1 by fieldbus.	40002	
1106	REF2 SELECT	8 (COMM)	Input reference 2 by fieldbus.	40003	

Reference Scaling

Where required, REFERENCES can be scaled. See the following, as appropriate:

- Modbus Register "40002" in the "Modbus Protocol Technical Data" section.
- "Reference Scaling" in the "ABB Control Profiles Technical Data" section.

Miscellaneous Drive Control

Using the fieldbus for miscellaneous drive control requires:

- Drive parameter values set as defined below.
- Fieldbus controller supplied command(s) in the appropriate location. (The location is defined by the Protocol Reference, which is protocol dependent.)

Drive Parameter		Value	Description	Modbus Protocol Reference	
				ABB DRV	DCU PROFILE
1601	RUN ENABLE	7 (COMM)	Run enable by fieldbus.	40001 bit 3	40031 bit 6 (inverted)
1604	FAULT RESET SEL	8 (COMM)	Fault reset by fieldbus.	40001 bit 7	40031 bit 4
1606	LOCAL LOCK	8 (COMM)	Source for local lock selection is the fieldbus.	Does not apply	40031 bit 14
1607	PARAM SAVE	1 (SAVE)	Saves altered parameters to memory (then value returns to 0).	41607	
1608	START ENABLE 1	7 (COMM)	Source for start enable 1 is the fieldbus Command word.	Does not apply.	40032 bit 2
1609	START ENABLE 2	7 (COMM)	Source for start enable 2 is the fieldbus Command word.		40032 bit 3
2201	ACC/DEC 1/2 SEL	7 (COMM)	Source for ramp pair selection is the fieldbus.		40031 bit 10

Relay Output Control

Using the fieldbus for relay output control requires:

- Drive parameter values set as defined below.
- Fieldbus controller supplied, binary coded, relay command(s) in the appropriate location. (The location is defined by the Protocol Reference, which is protocol dependent.)

Drive Parameter		Value	Description	Modbus Protocol Reference	
				ABB DRV	DCU PROFILE
1401	RELAY OUTPUT 1	35 (COMM)	Relay Output 1 controlled by fieldbus.	40134 bit 0 or 00033	
1402	RELAY OUTPUT 2	35 (COMM)	Relay Output 2 controlled by fieldbus.	40134 bit 1 or 00034	
1403	RELAY OUTPUT 3	35 (COMM)	Relay Output 3 controlled by fieldbus.	40134 bit 2 or 00035	
1410 (Note 1)	RELAY OUTPUT 4	35 (COMM)	Relay Output 4 controlled by fieldbus.	40134 bit 3 or 00036	
1411 (Note 1)	RELAY OUTPUT 5	35 (COMM)	Relay Output 5 controlled by fieldbus.	40134 bit 4 or 00037	
1412 (Note 1)	RELAY OUTPUT 6	35 (COMM)	Relay Output 6 controlled by fieldbus.	40134 bit 5 or 00038	

1. More than 3 relays requires the addition of a relay extension module.

Note! Relay status feedback occurs without configuration as defined below.

Drive Parameter		Description	Modbus Protocol Reference	
			ABB DRV	DCU PROFILE
0122	RO 1-3 STATUS	Relay 1...3 status.	40122	
0123	RO 4-6 STATUS	Relay 4...6 status.	40123	

Analog Output Control

Using the fieldbus for analog output control (e.g. PID setpoint) requires:

- Drive parameter values set as defined below.
- Fieldbus controller supplied analog value(s) in the appropriate location. (The location is defined by the Protocol Reference, which is protocol dependent.)

Drive Parameter		Value	Description	Modbus Protocol Reference	
				ABB DRV	DCU PROFILE
1501	AO1 CONTENT SEL	135 (COMM VALUE 1)	Analog Output 1 controlled by writing to parameter 0135.	-	
0135	COMM VALUE 1	-		40135	
1507	AO2 CONTENT SEL	136 (COMM VALUE 2)	Analog Output 2 controlled by writing to parameter 0136.	-	
0136	COMM VALUE 2	-		40136	

PID Control Setpoint Source

Using the following settings to select the fieldbus as the setpoint source for PID loops:

Drive Parameter		Value	Description	Modbus Protocol Reference	
				ABB DRV	DCU PROFILE
4010	SET POINT SEL (Set 1)	8 (COMM VALUE 1) 9 (COMM + AI1)	Setpoint is input reference 2 (+/-/* AI1)	40003	
4110	SET POINT SEL (Set 2)	10 (COMM*AI1)			
4210	SET POINT SEL (Ext/Trim)				

Communication Fault

When using fieldbus control, specify the drive's action if serial communication is lost.

Drive Parameter		Value	Description
3018	COMM FAULT FUNC	0 (NOT SEL) 1 (FAULT) 2 (CONST SP7) 3 (LAST SPEED)	Set for appropriate drive response.
3019	COMM FAULT TIME	Set time delay before acting on a communication loss.	

Feedback from the Drive – EFB

Pre-defined Feedback

Inputs to the controller (drive outputs) have pre-defined meanings established by the protocol. This feedback does not require drive configuration. The following table lists a sample of feedback data. For a complete listing, see input word/point/object listings in the technical data for the appropriate protocol starting on page 155.

Drive Parameter		Modbus Protocol Reference	
		ABB DRV	DCU PROFILE
0102	SPEED		40102
0103	OUTPUT FREQ		40103
0104	CURRENT		40104
0105	TORQUE		40105
0106	POWER		40106
0107	DC BUS VOLTAGE		40107
0109	OUTPUT VOLTAGE		40109
0301	FB CMD WORD1 – bit 0 (STOP)		40301 bit 0
0301	FB CMD WORD1 1 – bit 2 (REV)		40301 bit 2
0118	DI 1-3 STATUS – bit 0 (DI3)		40118

Note! With Modbus, any parameter can be accessed using the format: “4” followed by the parameter number.

Actual Value Scaling

The scaling of actual values can be protocol dependent. In general, for Actual Values, scale the feedback integer using the parameter's resolution. (See "Complete Parameter List for ACS510" section for parameter resolutions.) For example:

Feedback Integer	Parameter Resolution	(Feedback Integer) * (Parameter Resolution) = Scaled Value
1	0.1 mA	1 * 0.1 mA = 0.1 mA
10	0.1%	10 * 0.1% = 1%

Where parameters are in percent, the "Complete Parameter Descriptions" section specifies what parameter corresponds to 100%. In such cases, to convert from percent to engineering units, multiply by the value of the parameter that defines 100% and divide by 100%.

For example:

Feedback Integer	Parameter Resolution	Value of the Parameter that defines 100%	(Feedback Integer) * (Parameter Resolution) * (Value of 100% Ref.) / 100% = Scaled Value
10	0.1%	1500 rpm (Note 1)	$10 * 0.1\% * 1500 \text{ RPM} / 100\% = 15 \text{ rpm}$
100	0.1%	500 Hz (Note 2)	$100 * 0.1\% * 500 \text{ Hz} / 100\% = 50 \text{ Hz}$

1. Assuming, for the sake of this example, that the Actual Value uses parameter 9908 MOT NOM SPEED as the 100% reference, and that 9908 = 1500 rpm.
2. Assuming, for the sake of this example, that the Actual Value uses parameter 9907 MOT NOM FREQ as the 100% reference, and that 9907 = 500 Hz.

Diagnostics – EFB

Fault Queue for Drive Diagnostics

For general ACS510 diagnostics information, see "Diagnostics" starting on page 196. The three most recent ACS510 faults are reported to the fieldbus as defined below.

Drive Parameter		Modbus Protocol Reference	
		ABB DRV	DCU PROFILE
0401	Last Fault	40401	
0412	Previous Fault 1	40412	
0413	Previous Fault 2	40413	

Serial Communication Diagnostics

Network problems can be caused by multiple sources. Some of these sources are:

- Loose connections
- Incorrect wiring (including swapped wires)
- Bad grounding
- Duplicate station numbers
- Incorrect setup of drives or other devices on the network

The major diagnostic features for fault tracing on an EFB network include Group 53 EFB Protocol parameters 5306...5309. The "Complete Parameter Descriptions" section describes these parameters in detail.

Diagnostic Situations

The sub-sections below describe various diagnostic situations – the problem symptoms and corrective actions.

Normal Operation

During normal network operation, 5306...5309 parameter values act as follows at each drive:

- 5306 EFB OK MESSAGES advances (advances for each message properly received and addressed to this drive).
- 5307 EFB CRC ERRORS does not advance at all (advances when an invalid message CRC is received).
- 5308 EFB UART ERRORS does not advance at all (advances when character format errors are detected, such as parity or framing errors).
- 5309 EFB STATUS value varies depending on network traffic.

Loss of Communication

The ACS510ACS510 behavior, if communication is lost, was configured earlier in "Communication Fault". The parameters are 3018 COMM FAULT FUNC and 3019 COMM FAULT TIME. The "Complete Parameter Descriptions" section describes these parameters in detail.

No Master Station on Line

If no master station is on line: Neither the EFB OK MESSAGES nor the errors (5307 EFB CRC ERRORS and 5308 EFB UART ERRORS) increase on any of the stations.

To correct:

- Check that a network master is connected and properly programmed on the network.
- Verify that the cable is connected, and that it is not cut or short circuited.

Duplicate Stations

If two or more stations have duplicate numbers:

- Two or more drives cannot be addressed.
- Every time there is a read or write to one particular station, the value for 5307 EFB CRC ERRORS or 5308 EFB UART ERRORS advances.

To correct: Verify the station numbers of all stations. Change conflicting station numbers.

Swapped Wires

If the communication wires are swapped (terminal A on one drive is connected to terminal B on another):

- The value of 5306 EFB OK MESSAGES does not advance.
- The values of 5307 EFB CRC ERRORS and 5308 EFB UART ERRORS are advancing.

To correct: Check that the RS-485 lines are not swapped.

Fault 28 – Serial 1 Err

If the drive's control panel shows fault code 28 "SERIAL 1 ERR", check for either of the following:

- The master system is down. To correct, resolve problem with master system.
- The communication connection is bad. To correct, check communication connection at the drive.
- The time-out selection for the drive is too short for the given installation. The master is not polling the drive within the specified time-out delay. To correct, increase the time set by parameter 3019 COMM FAULT TIME.

Faults 31...33 – EFB1...EFB3

The three EFB fault codes listed for the drive in "Diagnostics" starting on page 196 (fault codes 31...33) are not used.

Intermittent Off-line Occurrences

The problems described above are the most common problems encountered with ACS510 serial communication. Intermittent problems might also be caused by:

- Marginally loose connections,
- Wear on wires caused by equipment vibrations,
- Insufficient grounding and shielding on both the devices and on the communication cables.

Modbus Protocol Technical Data

Overview

The Modbus® protocol was introduced by Modicon, Inc. for use in control environments featuring Modicon programmable controllers. Due to its ease of use and implementation, this common PLC language was quickly adopted as a de-facto standard for integration of a wide variety of master controllers and slave devices.

Modbus is a serial, asynchronous protocol. Transactions are half-duplex, featuring a single Master controlling one or more Slaves. While RS232 can be used for point-to-point communication between a single Master and a single Slave, a more common implementation features a multi-drop RS485 network with a single Master controlling multiple Slaves. The ACS510 features RS485 for its Modbus physical interface.

RTU

The Modbus specification defines two distinct transmission modes: ASCII and RTU. The ACS510 supports RTU only.

Feature Summary

The following Modbus function codes are supported by the ACS510.

Function	Code (Hex)	Description
Read Coil Status	0x01	Read discrete output status. For the ACS510, the individual bits of the control word are mapped to Coils 1...16. Relay outputs are mapped sequentially beginning with Coil 33 (e.g. RO1=Coil 33).
Read Discrete Input Status	0x02	Read discrete inputs status. For the ACS510, the individual bits of the status word are mapped to Inputs 1...16 or 1...32, depending on the active profile. Terminal inputs are mapped sequentially beginning with Input 33 (e.g. DI1=Input 33).
Read Multiple Holding Registers	0x03	Read multiple holding registers. For the ACS510, the entire parameter set is mapped as holding registers, as well as command, status and reference values.
Read Multiple Input Registers	0x04	Read multiple input registers. For the ACS510, the 2 analog input channels are mapped as input registers 1 & 2.
Force Single Coil	0x05	Write a single discrete output. For the ACS510, the individual bits of the control word are mapped to Coils 1...16. Relay outputs are mapped sequentially beginning with Coil 33 (e.g. RO1=Coil 33).
Write Single Holding Register	0x06	Write single holding register. For the ACS510, the entire parameter set is mapped as holding registers, as well as command, status and reference values.
Diagnostics	0x08	Perform Modbus diagnostics. Subcodes for Query (0x00), Restart (0x01) & Listen Only (0x04) are supported.
Force Multiple Coils	0x0F	Write multiple discrete outputs. For the ACS510, the individual bits of the control word are mapped to Coils 1...16. Relay outputs are mapped sequentially beginning with Coil 33 (e.g. RO1=Coil 33).
Write Multiple Holding Registers	0x10	Write multiple holding registers. For the ACS510, the entire parameter set is mapped as holding registers, as well as command, status and reference values.
Read/Write Multiple Holding Registers	0x17	This function combines functions 0x03 and 0x10 into a single command.

Mapping Summary

The following table summarizes the mapping between the ACS510 (parameters and I/O) and Modbus reference space. For details, see "Modbus Addressing" below.

ACS510	Modbus Reference	Supported Function Codes
<ul style="list-style-type: none"> Control Bits Relay Outputs 	Coils(0xxxx)	<ul style="list-style-type: none"> 01 – Read Coil Status 05 – Force Single Coil 15 – Force Multiple Coils
<ul style="list-style-type: none"> Status Bits Discrete Inputs 	Discrete Inputs(1xxxx)	<ul style="list-style-type: none"> 02 – Read Input Status
<ul style="list-style-type: none"> Analog Inputs 	Input Registers(3xxxxx)	<ul style="list-style-type: none"> 04 – Read Input Registers
<ul style="list-style-type: none"> Parameters Control/Status Words References 	Holding Registers(4xxxx)	<ul style="list-style-type: none"> 03 – Read 4X Registers 06 – Preset Single 4X Register 16 – Preset Multiple 4X Registers 23 – Read/Write 4X Registers

Communication Profiles

When communicating by Modbus, the ACS510 supports multiple profiles for control and status information. Parameter 5305 (EFB CTRL PROFILE) selects the profile used.

- ABB DRV LIM – The primary (and default) profile is the ABB DRV LIM profile. This implementation of the ABB Drives profile standardizes the control interface with ACS400 drives. The ABB Drives profile is based on the PROFIBUS interface, it is discussed in detail in the following sections.
- DCU PROFILE – The DCU PROFILE profile extends the control and status interface to 32 bits, it is the internal interface between the main drive application and the embedded fieldbus environment.
- ABB DRV FULL – ABB DRV FULL is the implementation of the ABB Drives profile that standardizes the control interface with ACS600 and ACS800 drives. This implementation supports two control word bits not supported by the ABB DRV LIM implementation.

Modbus Addressing

With Modbus, each function code implies access to a specific Modbus reference set. Thus, the leading digit is not included in the address field of a Modbus message.

Note: The ACS510 supports the zero-based addressing of the Modbus specification. Holding register 40002 is addressed as 0001 in a Modbus message. Similarly, coil 33 is addressed as 0032 in a Modbus message.

Refer again to the "Mapping Summary" above. The following sections describe, in detail, the mapping to each Modbus reference set.

0xxxx Mapping – Modbus Coils. The drive maps the following information to the 0xxxx Modbus set called Modbus Coils:

- Bit-wise map of the CONTROL WORD (selected using parameter 5305 EFB CTRL PROFILE). The first 32 coils are reserved for this purpose.

- Relay output states, numbered sequentially beginning with coil 00033.

The following table summarizes the 0xxxx reference set:

Modbus Ref.	Internal Location (All Profiles)	ABB DRV LIM (5305 = 0)	DCU PROFILE (5305 = 1)	ABB DRV FULL (5305 = 2)
00001	CONTROL WORD – Bit 0	OFF1*	STOP	OFF1*
00002	CONTROL WORD – Bit 1	OFF2*	START	OFF2*
00003	CONTROL WORD – Bit 2	OFF3*	REVERSE	OFF3*
00004	CONTROL WORD – Bit 3	START	LOCAL	START
00005	CONTROL WORD – Bit 4	N/A	RESET	RAMP_OUT_ZERO*
00006	CONTROL WORD – Bit 5	RAMP_HOLD*	EXT2	RAMP_HOLD*
00007	CONTROL WORD – Bit 6	RAMP_IN_ZERO*	RUN_DISABLE	RAMP_IN_ZERO*
00008	CONTROL WORD – Bit 7	RESET	STPMODE_R	RESET
00009	CONTROL WORD – Bit 8	N/A	STPMODE_EM	N/A
00010	CONTROL WORD – Bit 9	N/A	STPMODE_C	N/A
00011	CONTROL WORD – Bit 10	N/A	RAMP_2	REMOTE_CMD*
00012	CONTROL WORD – Bit 11	EXT2	RAMP_OUT_0	EXT2
00013	CONTROL WORD – Bit 12	N/A	RAMP_HOLD	N/A
00014	CONTROL WORD – Bit 13	N/A	RAMP_IN_0	N/A
00015	CONTROL WORD – Bit 14	N/A	REQ_LOCALLOCK	N/A
00016	CONTROL WORD – Bit 15	N/A	TORQLIM2	N/A
00017	CONTROL WORD – Bit 16	Does not apply	FBLOCAL_CTL	Does not apply
00018	CONTROL WORD – Bit 17		FBLOCAL_REF	
00019	CONTROL WORD – Bit 18		START_DISABLE1	
00020	CONTROL WORD – Bit 19		START_DISABLE2	
00021... 00032	Reserved	Reserved	Reserved	Reserved
00033	RELAY OUTPUT 1	Relay Output 1	Relay Output 1	Relay Output 1
00034	RELAY OUTPUT 2	Relay Output 2	Relay Output 2	Relay Output 2
00035	RELAY OUTPUT 3	Relay Output 3	Relay Output 3	Relay Output 3
00036	RELAY OUTPUT 4	Relay Output 4	Relay Output 4	Relay Output 4
00037	RELAY OUTPUT 5	Relay Output 5	Relay Output 5	Relay Output 5
00038	RELAY OUTPUT 6	Relay Output 6	Relay Output 6	Relay Output 6

* = Active low

For the 0xxxx registers:

- Status is always readable.
- Forcing is allowed by user configuration of the drive for fieldbus control.
- Additional relay outputs are added sequentially.

The ACS510 supports the following Modbus function codes for coils:

Function Code	Description
01	Read coil status
05	Force single coil
15 (0x0F Hex)	Force multiple coils

1xxxx Mapping – Modbus Discrete Inputs. The drive maps the following information to the 1xxxx Modbus set called Modbus Discrete Inputs:

- Bit-wise map of the STATUS WORD (selected using parameter 5305 EFB CTRL PROFILE). The first 32 inputs are reserved for this purpose.
- Discrete hardware inputs, numbered sequentially beginning with input 33.

The following table summarizes the 1xxxx reference set:

Modbus Ref.	Internal Location (All Profiles)	ABB DRV (5305 = 0 OR 2)	DCU PROFILE (5305 = 1)
10001	STATUS WORD – Bit 0	RDY_ON	READY
10002	STATUS WORD – Bit 1	RDY_RUN	ENABLED
10003	STATUS WORD – Bit 2	RDY_REF	STARTED
10004	STATUS WORD – Bit 3	TRIPPED	RUNNING
10005	STATUS WORD – Bit 4	OFF_2_STA*	ZERO_SPEED
10006	STATUS WORD – Bit 5	OFF_3_STA*	ACCELERATE
10007	STATUS WORD – Bit 6	SWC_ON_INHIB	DECELERATE
10008	STATUS WORD – Bit 7	ALARM	AT_SETPOINT
10009	STATUS WORD – Bit 8	AT_SETPOINT	LIMIT
10010	STATUS WORD – Bit 9	REMOTE	SUPERVISION
10011	STATUS WORD – Bit 10	ABOVE_LIMIT	REV_REF
10012	STATUS WORD – Bit 11	EXT2	REV_ACT
10013	STATUS WORD – Bit 12	RUN_ENABLE	PANEL_LOCAL
10014	STATUS WORD – Bit 13	N/A	FIELDBUS_LOCAL
10015	STATUS WORD – Bit 14	N/A	EXT2_ACT
10016	STATUS WORD – Bit 15	N/A	FAULT
10017	STATUS WORD – Bit 16	Reserved	ALARM
10018	STATUS WORD – Bit 17	Reserved	REQ_MAINT
10019	STATUS WORD – Bit 18	Reserved	DIRLOCK
10020	STATUS WORD – Bit 19	Reserved	LOCALLOCK
10021	STATUS WORD – Bit 20	Reserved	CTL_MODE
10022	STATUS WORD – Bit 21	Reserved	Reserved
10023	STATUS WORD – Bit 22	Reserved	Reserved
10024	STATUS WORD – Bit 23	Reserved	Reserved
10025	STATUS WORD – Bit 24	Reserved	Reserved
10026	STATUS WORD – Bit 25	Reserved	Reserved
10027	STATUS WORD – Bit 26	Reserved	REQ_CTL

Modbus Ref.	Internal Location (All Profiles)	ABB DRV (5305 = 0 OR 2)	DCU PROFILE (5305 = 1)
10028	STATUS WORD – Bit 27	Reserved	REQ_REF1
10029	STATUS WORD – Bit 28	Reserved	REQ_REF2
10030	STATUS WORD – Bit 29	Reserved	REQ_REF2EXT
10031	STATUS WORD – Bit 30	Reserved	ACK_STARTINH
10032	STATUS WORD – Bit 31	Reserved	ACK_OFF_ILCK
10033	DI1	DI1	DI1
10034	DI2	DI2	DI2
10035	DI3	DI3	DI3
10036	DI4	DI4	DI4
10037	DI5	DI5	DI5
10038	DI6	DI6	DI6

* = Active low

For the 1xxxx registers:

- Additional discrete inputs are added sequentially.

The ACS510 supports the following Modbus function codes for discrete inputs:

Function Code	Description
02	Read input status

3xxxx Mapping – Modbus Inputs. The drive maps the following information to the 3xxxx Modbus addresses called Modbus input registers:

- Any user defined analog inputs.

The following table summarizes the input registers:

Modbus Reference	ACS510 All Profiles	Remarks
30001	AI1	This register shall report the level of Analog Input 1 (0...100%).
30002	AI2	This register shall report the level of Analog Input 2 (0...100%).

The ACS510 supports the following Modbus function codes for 3xxxx registers:

Function Code	Description
04	Read 3xxxx input status

4xxxx Register Mapping. The drive maps its parameters and other data to the 4xxxx holding registers as follows:

- 40001...40099 map to drive control and actual values. These registers are described in the table below.
- 40101...49999 map to drive parameters 0101...9999. Register addresses that do not correspond to drive parameters are invalid. If there is an attempt to read or write outside the parameter addresses, the Modbus interface returns an exception code to the controller.

The following table summarizes the 4xxxx drive control registers 40001...40099 (for 4xxxx registers above 40099, see the drive parameter list, e.g. 40102 is parameter 0102):

Modbus Register		Access	Remarks
40001	CONTROL WORD	R/W	Maps directly to the profile's CONTROL WORD. Supported only if 5305 = 0 or 2 (ABB Drives profile). Parameter 5319 holds a copy in hex format.
40002	Reference 1	R/W	Range = 0...+20000 (scaled to 0...1105 REF1 MAX), or -20000...0 (scaled to 1105 REF1 MAX...0).
40003	Reference 2	R/W	Range = 0...+10000 (scaled to 0...1108 REF2 MAX), or -10000...0 (scaled to 1108 REF2 MAX...0).
40004	STATUS WORD	R	Maps directly to the profile's STATUS WORD. Supported only if 5305 = 0 or 2 (ABB Drives profile). Parameter 5320 holds a copy in hex format.
40005	Actual 1 (select using 5310)	R	By default, stores a copy of 0103 OUTPUT FREQ. Use parameter 5310 to select a different actual value for this register.
40006	Actual 2 (select using 5311)	R	By default, stores a copy of 0104 CURRENT. Use parameter 5311 to select a different actual value for this register.
40007	Actual 3 (select using 5312)	R	By default, stores nothing. Use parameter 5312 to select an actual value for this register.
40008	Actual 4 (select by 5313)	R	By default, stores nothing. Use parameter 5313 to select an actual value for this register.
40009	Actual 5 (select using 5314)	R	By default, stores nothing. Use parameter 5314 to select an actual value for this register.
40010	Actual 6 (select using 5315)	R	By default, stores nothing. Use parameter 5315 to select an actual value for this register.
40011	Actual 7 (select using 5316)	R	By default, stores nothing. Use parameter 5316 to select an actual value for this register.
40012	Actual 8 (select using 5317)	R	By default, stores nothing. Use parameter 5317 to select an actual value for this register.
40031	ACS510 CONTROL WORD LSW	R/W	Maps directly to the Least Significant Word of the DCU profile's CONTROL WORD. Supported only if 5305 = 1. See parameter 0301.
40032	ACS510 CONTROL WORD MSW	R	Maps directly to the Most Significant Word of the DCU profile's CONTROL WORD. Supported only if 5305 = 1. See parameter 0302.
40033	ACS510 STATUS WORD LSW	R	Maps directly to the Least Significant Word of the DCU profile's STATUS WORD. Supported only if 5305 = 1. See parameter 0303.
40034	ACS510 STATUS WORD MSW	R	Maps directly to the Most Significant Word of the DCU profile's STATUS WORD. Supported only if 5305 = 1. See parameter 0304.

For the Modbus protocol, drive parameters in group 53 report the parameter mapping to 4xxx Registers.

Code	Description
5310	EFB PAR 10 Specifies the parameter mapped to Modbus register 40005.
5311	EFB PAR 11 Specifies the parameter mapped to Modbus register 40006.
5312	EFB PAR 12 Specifies the parameter mapped to Modbus register 40007.
5313	EFB PAR 13 Specifies the parameter mapped to Modbus register 40008.
5314	EFB PAR 14 Specifies the parameter mapped to Modbus register 40009.
5315	EFB PAR 15 Specifies the parameter mapped to Modbus register 40010.
5316	EFB PAR 16 Specifies the parameter mapped to Modbus register 40011.
5317	EFB PAR 17 Specifies the parameter mapped to Modbus register 40012.
5318	EFB PAR 18 Sets additional delay in millisecond before the ACS510 begins transmitting response to the master request.
5319	EFB PAR 19 Holds a copy (in hex) of the CONTROL WORD, Modbus register 40001.
5320	EFB PAR 20 Holds a copy (in hex) of the STATUS WORD, Modbus register 40004.

Except where restricted by the drive, all parameters are available for both reading and writing. The parameter writes are verified for the correct value, and for a valid register addresses.

Note! Parameter writes through standard Modbus are always volatile i.e. modified values are not automatically stored to permanent memory. Use parameter 1607 PARAM. SAVE to save all altered values.

The ACS510 supports the following Modbus function codes for 4xxx registers:

Function Code	Description
03	Read holding 4xxx registers
06	Preset single 4xxx register
16 (0x10 Hex)	Preset multiple 4xxx registers
23 (0x17 Hex)	Read/write 4xxx registers

Actual Values

The contents of the register addresses 40005...40012 are ACTUAL VALUES and are:

- Specified using parameters 5310...5317.
- Read-only values containing information on the operation of the drive.
- 16-bit words containing a sign bit and a 15-bit integer.
- When negative values, written as the two's complement of the corresponding positive value.
- Scaled as described earlier in "Actual Value Scaling".

Exception Codes

Exception codes are serial communication responses from the drive. The ACS510 supports the standard Modbus exception codes defined below.

Exception Code	Name	Meaning
01	ILLEGAL FUNCTION	Unsupported Command
02	ILLEGAL DATA ADDRESS	The data address received in the query is not allowable. It is not a defined parameter/group.
03	ILLEGAL DATA VALUE	A value contained in the query data field is not an allowable value for the ACS510, because it is one of the following: <ul style="list-style-type: none"> • Outside min. or max. limits. • Parameter is read-only. • Message is too long. • Parameter write not allowed when start is active. • Parameter write not allowed when factory macro is selected.

For the Modbus protocol, a drive parameter in group 53 holds the most recent exception code:

Code	Description
5318	EFB PAR 18 Holds the most recent exception code.

ABB Control Profiles Technical Data

Overview

ABB Drives Profile

The ABB Drives profile provides a standard profile that can be used on multiple protocols, including Modbus and the protocols available on the FBA module. Two implementations of the ABB Drives profile are available:

- ABB DRV FULL – This implementation standardizes the control interface with ACS600 and ACS800 drives.
- ABB DRV LIM – This implementation standardizes the control interface with ACS400 drives. This implementation does not support two control word bits supported by ABB DRV FULL.

Except as noted, the following “ABB Drives Profile” descriptions apply to both implementations.

DCU Profile

The DCU profile extends the control and status interface to 32 bits, and is the internal interface between the main drive application and the embedded fieldbus environment.

Control Word

The CONTROL WORD is the principal means for controlling the drive from a fieldbus system. The fieldbus master station sends the CONTROL WORD to the drive. The drive switches between states according to the bit-coded instructions in the CONTROL WORD. Using the CONTROL WORD requires that:

- The drive is in remote (REM) control.
- The serial communication channel is defined as the source for controlling commands (set using parameters such as 1001 EXT1 COMMANDS, 1002 EXT2 COMMANDS and 1102 EXT1/EXT2 SEL).
- The serial communication channel used is configured to use an ABB control profile. For example, to use the control profile ABB DRV FULL, requires both parameter 9802 COMM PROT SEL = 1 (STD MODBUS), and parameter 5305 EFB CTRL PROFILE = 2 (ABB DRV FULL).

ABB Drives Profile

The following table and the state diagram later in this sub-section describe the CONTROL WORD content for the ABB Drives profile.

ABB Drives Profile CONTROL WORD (See Parameter 5319)				
Bit	Name	Value	Commanded State	Comments
0	OFF1 CONTROL	1	READY TO OPERATE	Enter READY TO OPERATE
		0	EMERGENCY OFF	Drive ramps to stop according to currently active deceleration ramp (2203 or 2205) Normal command sequence: <ul style="list-style-type: none"> • Enter OFF1 ACTIVE • Proceed to READY TO SWITCH ON, unless other interlocks (OFF2, OFF3) are active.
1	OFF2 CONTROL	1	OPERATING	Continue operation (OFF2 inactive)
		0	EMERGENCY OFF	Drive coasts to stop. Normal command sequence: <ul style="list-style-type: none"> • Enter OFF2 ACTIVE • Proceed to SWITCHON INHIBITED
2	OFF3 CONTROL	1	OPERATING	Continue operation (OFF3 inactive)
		0	EMERGENCY STOP	Drive stops within in time specified by parameter 2208. Normal command sequence: <ul style="list-style-type: none"> • Enter OFF3 ACTIVE • Proceed to SWITCH ON INHIBITED WARNING! Be sure motor and driven equipment can be stopped using this mode.
3	INHIBIT OPERATION	1	OPERATION ENABLED	Enter OPERATION ENABLED (Note the Run enable signal must be active. See 1601. If 1601 is set to COMM, this bit also activates the Run Enable signal.)
		0	OPERATION INHIBITED	Inhibit operation. Enter OPERATION INHIBITED
4	Unused (ABB DRV LIM)			
	RAMP_OUT_ZERO (ABB DRV FULL)	1	NORMAL OPERATION	Enter RAMP FUNCTION GENERATOR: ACCELERATION ENABLED
		0	RFG OUT ZERO	Force ramp function generator output to Zero. Drive ramps to stop (current and DC voltage limits in force).
5	RAMP_HOLD	1	RFG OUT ENABLED	Enable ramp function. Enter RAMP FUNCTION GENERATOR: ACCELERATOR ENABLED
		0	RFG OUT HOLD	Halt ramping (Ramp Function Generator output held)
6	RAMP_IN_ZERO	1	RFG INPUT ENABLED	Normal operation. Enter OPERATING
		0	RFG INPUT ZERO	Force Ramp Function Generator input to zero.

ABB Drives Profile CONTROL WORD (See Parameter 5319)				
Bit	Name	Value	Commanded State	Comments
7	RESET	0=>1	RESET	Fault reset if an active fault exists (Enter SWITCH-ON INHIBITED). Effective if 1604 = COMM.
		0	OPERATING	Continue normal operation
8...9	Unused			
10	Unused (ABB DRV LIM)			
	REMOTE_CMD (ABB DRV FULL)	1		Fieldbus control enabled.
		0		<ul style="list-style-type: none"> CW ≠ 0 or Ref ≠ 0: Retain last CW and Ref. CW = 0 and Ref = 0: Fieldbus control enabled. Ref and deceleration/acceleration ramp are locked.
11	EXT CTRL LOC	1	EXT2 SELECT	Select external control location 2 (EXT2). Effective if 1102 = COMM.
		0	EXT1 SELECT	Select external control location 1 (EXT1). Effective if 1102 = COMM.
12...15	Unused			

DCU Profile

The following tables describe the CONTROL WORD content for the DCU profile.

DCU Profile CONTROL WORD (See Parameter 0301)				
Bit	Name	Value	Command/Req.	Comments
0	STOP	1	Stop	Stops according to either the stop mode parameter or the stop mode requests (bits 7 and 8).
		0	(no op)	
1	START	1	Start	Simultaneous STOP and START commands result in a stop command.
		0	(no op)	
2	REVERSE	1	Reverse direction	This bit XOR'd with the sign of the reference defines direction.
		0	Forward direction	
3	LOCAL	1	Local mode	When the fieldbus sets this bit, it steals control and the drive moves to fieldbus local control mode.
		0	External mode	
4	RESET	-> 1	Reset	Edge sensitive.
		other	(no op)	
5	EXT2	1	Switch to EXT2	
		0	Switch to EXT1	
6	RUN_DISABLE	1	Run disable	Inverted run enable.
		0	Run enable on	
7	STPMODE_R	1	Normal ramp stop mode	
		0	(no op)	

DCU Profile CONTROL WORD (See Parameter 0301)				
Bit	Name	Value	Command/Req.	Comments
8	STPMODE_EM	1	Emergency ramp stop mode	
		0	(no op)	
9	STPMODE_C	1	Coast stop mode	
		0	(no op)	
10	RAMP_2	1	Ramp pair 2	
		0	Ramp pair 1	
11	RAMP_OUT_0	1	Ramp output to 0	
		0	(no op)	
12	RAMP_HOLD	1	Ramp freeze	
		0	(no op)	
13	RAMP_IN_0	1	Ramp input to 0	
		0	(no op)	
14	RREQ_LOCALL OC	1	Local mode lock	In lock, drive will not switch to local mode.
		0	(no op)	
15	RESERVED			

DCU Profile CONTROL WORD (See Parameter 0302)				
Bit	Name	Value	Function	Comments
16...26	Reserved			
27	REF_CONST	1	Constant speed ref.	These bits are only for supervision purposes.
		0	(no op)	
28	REF_AVE	1	Average speed ref.	
		0	(no op)	
29	LINK_ON	1	Master is detected in link	
		0	Link is down	
30	REQ_STARTINH	1	Start inhibit request is pending	
		0	Start inhibit request is OFF	
31	OFF_INTERLOCK	1	Panel OFF button pressed	For the control panel (or PC tool) this is the OFF button interlock.
		0	(no op)	

Status Word

The contents of the STATUS WORD is status information, sent by the drive to the master station.

ABB Drives Profile

The following table and the state diagram later in this sub-section describe the STATUS WORD content for the ABB Drives profile.

ABB Drives Profile (EFB) STATUS WORD (See Parameter 5320)			
Bit	Name	Value	Description (Correspond to states/boxes in the state diagram)
0	RDY_ON	1	READY TO SWITCH ON
		0	NOT READY TO SWITCH ON
1	RDY_RUN	1	READY TO OPERATE
		0	OFF1 ACTIVE
2	RDY_REF	1	OPERATION ENABLED
		0	OPERATION INHIBITED
3	TRIPPED	0...1	FAULT
		0	No fault
4	OFF_2_STA	1	OFF2 INACTIVE
		0	OFF2 ACTIVE
5	OFF_3_STA	1	OFF3 INACTIVE
		0	OFF3 ACTIVE
6	SWC_ON_INHIB	1	SWITCH-ON INHIBIT ACTIVE
		0	SWITCH-ON INHIBIT NOT ACTIVE
7	ALARM	1	Warning/alarm (See "Alarm Listing" in the "Diagnostics" section for details on alarms.)
		0	No warning/alarm
8	AT_SETPOINT	1	OPERATING. Actual value equals (within tolerance limits) the reference value.
		0	Actual value is outside tolerance limits (not equal to reference value).
9	REMOTE	1	Drive control location: REMOTE (EXT1 or EXT2)
		0	Drive control location: LOCAL
10	ABOVE_LIMIT	1	Supervised parameter's value \geq supervision high limit. Bit remains "1" until supervised parameter's value < supervision low limit. See group 32, Supervision
		0	Supervised parameter's value < supervision low limit. Bit remains "0" until supervised parameter's value > supervision high limit. See group 32, Supervision
11	EXT CTRL LOC	1	External control location 2 (EXT2) selected
		0	External control location 1 (EXT1) selected
12	EXT RUN ENABLE	1	External Run Enable signal received
		0	No External Run Enable signal received
13... 15	Unused		

DCU Profile

The following tables describe the STATUS WORD content for the DCU profile.

DCU Profile STATUS WORD (See Parameter 0303)			
Bit	Name	Value	Status
0	READY	1	Drive is ready to receive start command.
		0	Drive is not ready.
1	ENABLED	1	External run enable signal received.
		0	No external run enable signal received.
2	STARTED	1	Drive has received start command.
		0	Drive has not received start command.
3	RUNNING	1	Drive is modulating.
		0	Drive is not modulating.
4	ZERO_SPEED	1	Drive is at zero speed.
		0	Drive has not reached zero speed.
5	ACCELERATE	1	Drive is accelerating.
		0	Drive is not accelerating.
6	DECELERATE	1	Drive is decelerating.
		0	Drive is not decelerating.
7	AT_SETPOINT	1	Drive is at setpoint.
		0	Drive has not reached setpoint.
8	LIMIT	1	Operation is limited by Group 20 settings.
		0	Operation is within Group 20 settings.
9	SUPERVISION	1	A supervised parameter (Group 32) is outside its limits.
		0	All supervised parameters are within limits.
10	REV_REF	1	Drive reference is in reverse direction.
		0	Drive reference is in forward direction.
11	REV_ACT	1	Drive is running in reverse direction.
		0	Drive is running in forward direction.
12	PANEL_LOCAL	1	Control is in control panel (or PC tool) local mode.
		0	Control is not in control panel local mode.
13	FIELDDBUS_LOCAL	1	Control is in fieldbus local mode (steals control panel local).
		0	Control is not in fieldbus local mode.
14	EXT2_ACT	1	Control is in EXT2 mode.
		0	Control is in EXT1 mode.
15	FAULT	1	Drive is in a fault state.
		0	Drive is not in a fault state.

DCU Profile STATUS WORD (See Parameter 0304)			
Bit	Name	Value	Status
16	ALARM	1	An alarm is on.
		0	No alarms are on.
17	REQ_MAINT	1	A maintenance request is pending.
		0	No maintenance request is pending.
18	DIRLOCK	1	Direction lock is ON. (Direction change is locked out.)
		0	Direction lock is OFF.
19	LOCALLOCK	1	Local mode lock is ON. (Local mode is locked out.)
		0	Local mode lock is OFF.
20...25	Reserved		
26	REQ_CTL	1	Copy the control word
		0	(no op)
27	REQ_REF1	1	Reference 1 requested in this channel.
		0	Reference 1 is not requested in this channel.
28	REQ_REF2	1	Reference 2 requested in this channel.
		0	Reference 2 is not requested in this channel.
29	REQ_REF2EXT	1	External PID reference 2 requested in this channel.
		0	External PID reference 2 is not requested in this channel.
30	ACK_STARTINH	1	A start inhibit from this channel is granted.
		0	A start inhibit from this channel is not granted.
31	ACK_OFF_ILCK	1	Start inhibit due to OFF button
		0	Normal operation

State Diagram

ABB Drives Profile

To illustrate the operation of the state diagram, the following example (ABB DRV LIM implementation of the ABB Drives profile) uses the control word to start the drive:

- First, the requirements for using the CONTROL WORD must be met. See above.
- When the power is first connected, the state of the drive is not ready to switch on. See dotted lined path (---) in the state diagram below.
- Use the CONTROL WORD to step through the state machine states until the OPERATING state is reached, meaning that the drive is running and follows the given reference. See table below.

Step	CONTROL WORD Value	Description
1	CW = 0000 0000 0000 0110 <div style="display: flex; justify-content: space-around; width: 100%;"> <div style="text-align: center;"> bit 15</div> <div style="text-align: center;"> bit 0</div> </div>	This CW value changes the drive state to READY TO SWITCH ON.
2		Wait at least 100 ms before proceeding.
3	CW = 0000 0000 0000 0111	This CW value changes the drive state to READY TO OPERATE.
4	CW = 0000 0000 0000 1111	This CW value changes the drive state to OPERATION ENABLED. The drive starts, but will not accelerate.
5	CW = 0000 0000 0010 1111	This CW value releases the ramp function generator (RFG) output, and changes the drive state to RFG: ACCELERATOR ENABLED.
6	CW = 0000 0000 0110 1111	This CW value releases the ramp function generator (RFG) output, and changes the drive state to OPERATING. The drive accelerates to the given reference and follows the reference.

The state diagram below describes the start-stop function of CONTROL WORD (CW) and STATUS WORD (SW) bits for the ABB Drives profile.

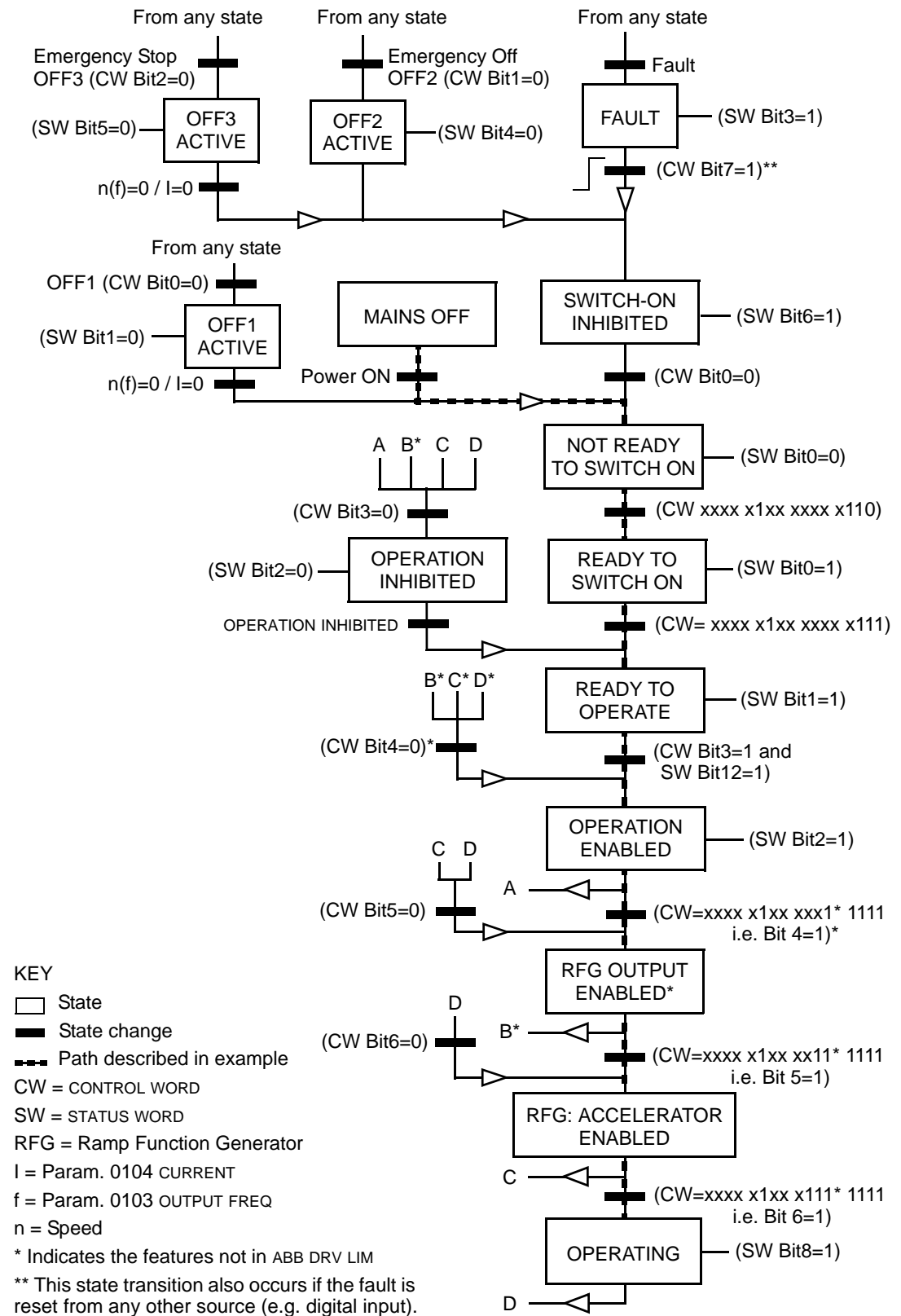

Reference Scaling

ABB Drives and DCU Profiles

The following table describes REFERENCE scaling for the ABB Drives and DCU profiles.

ABB Drives and DCU Profiles				
Reference	Range	Reference Type	Scaling	Remarks
REF1	-32767 ... +32767	Frequency	-20000 = -(par. 1105) 0 = 0 +20000 = (par. 1105) (20000 corresponds to 100%)	Final reference limited by 1104/1105. Actual motor speed limited by 2007/2008 (frequency).
REF2	-32767 ... +32767	Frequency	-10000 = -(par. 1108) 0 = 0 +10000 = (par. 1108) (10000 corresponds to 100%)	Final reference limited by 1107/1108. Actual motor speed limited by 2007/2008 (frequency).
		PID Reference	-10000 = -(par. 1108) 0 = 0 +10000 = (par. 1108) (10000 corresponds to 100%)	Final reference limited by 4012/4013 (PID set1) or 4112/4113 (PID set2).

Note! The setting of parameter 1104 REF1 MIN and 1107 REF2 MIN has no effect on the scaling of references.

When parameter 1103 REF1 SELECT or 1106 REF2 SELECT is set to COMM+AI1 or COMM*AI1, the reference is scaled as follows:

ABB Drives and DCU Profiles		
Reference	Value Setting	AI Reference Scaling
REF1	COMM+AI1	$\text{COMM (\%)} + (\text{AI (\%)} - 0.5 \cdot \text{REF1 MAX (\%)})$

ABB Drives and DCU Profiles		
Reference	Value Setting	AI Reference Scaling
REF1	COMM*AI1	$\text{COMM (\%)} * (\text{AI (\%)} / 0.5 * \text{REF1 MAX (\%)})$ <p>(100 - 0.5 * (par. 1105))%</p>
REF2	COMM+AI1	$\text{COMM (\%)} + (\text{AI (\%)} - 0.5 * \text{REF2 MAX (\%)})$ <p>(100 + 0.5 * (Par. 1108))%</p> <p>(100 - 0.5 * (par. 1108))%</p>
REF2	COMM*AI1	$\text{COMM (\%)} * (\text{AI (\%)} / 0.5 * \text{REF2 MAX (\%)})$

Reference Handling

Use group 10 parameters to configure for control of rotation direction for each control location (EXT1 and EXT2). The following diagrams illustrate how group 10 parameters and the sign of the fieldbus reference interact to produce REFERENCE values (REF1 and REF2). Note, fieldbus references are bipolar, that is they can be positive or negative.

ABB Drives Profile		
Parameter	Value Setting	AI Reference Scaling
1003 DIRECTION*	1 (FORWARD)	
1003 DIRECTION*	2 (REVERSE)	
1003 DIRECTION*	3 (REQUEST)	

* This parameter is not available in software option +N688 and +N689.

Fieldbus Adapter

Overview

The ACS510 can be set up to accept control from an external system using standard serial communication protocols. When using serial communication, the ACS510 can either:

- Receive all of its control information from the fieldbus, or
- Be controlled from some combination of fieldbus control and other available control locations, such as digital or analog inputs, and the control panel.

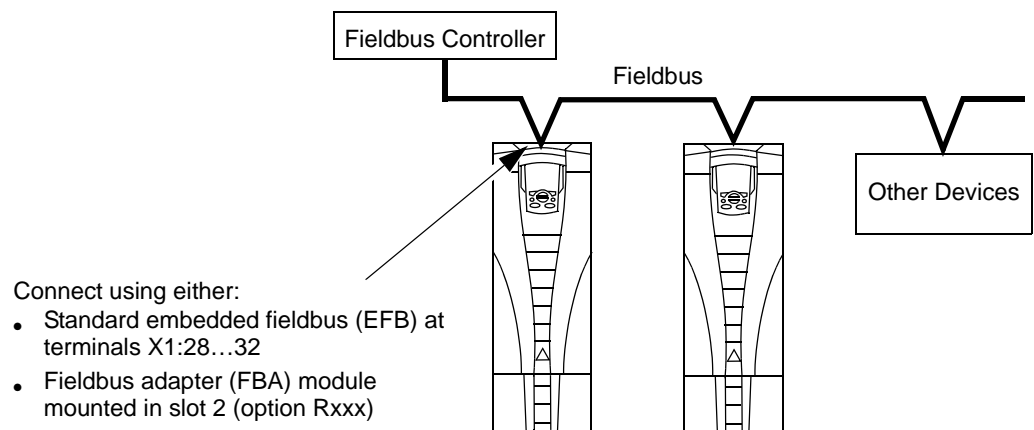

Two basic serial communications configurations are available:

- Embedded fieldbus (EFB) – See "Embedded Fieldbus" on page 143.
- Fieldbus adapter (FBA) – With one of the optional FBA modules in the drive's expansion slot 2, the drive can communicate to a control system using one of the following protocols:
 - Profibus-DP®
 - LonWorks®
 - CANopen®
 - DeviceNet®
 - ControlNet®

The ACS510 detects automatically which communication protocol is used by the plug-in fieldbus adapter. The default settings for each protocol assume that the profile used is the protocol's industry-standard drive profile (e.g. PROFIdrive for PROFIBUS, AC/DC Drive for DeviceNet). All of the FBA protocols can also be configured for the ABB Drives profile.

Configuration details depend on the protocol and profile used. These details are provided in a user's manual supplied with the FBA module.

Details for the ABB Drives profile (which apply for all protocols) are provided in "ABB Drives Profile Technical Data" on page 186.

Control Interface

In general, the basic control interface between the fieldbus system and the drive consists of:

- Output Words:
 - CONTROL WORD
 - REFERENCE (frequency)
 - Others: The drive supports a maximum of 15 output words. Protocol limits may further restrict the total.
- Input Words:
 - STATUS WORD
 - Actual Value (frequency)
 - Others: The drive supports a maximum of 15 input words. Protocol limits may further restrict the total.

Note! The words “output” and “input” are used as seen from the fieldbus controller point of view. For example an output describes data flow from the fieldbus controller to the drive and appears as an input from the drive point of view.

The meanings of the controller interface words are not restricted by the ACS510. However, the profile used may set particular meanings.

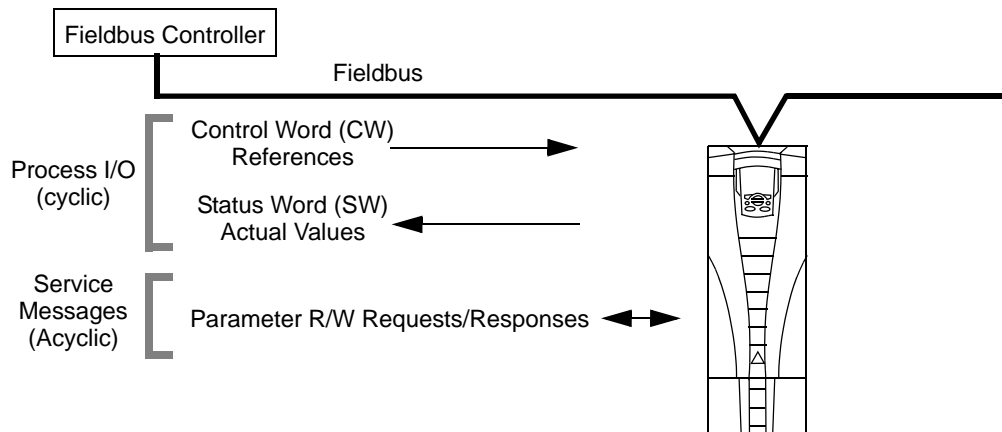

Control Word

The CONTROL WORD is the principal means for controlling the drive from a fieldbus system. The fieldbus controller sends the CONTROL WORD to the drive. The drive switches between states according to the bit-coded instructions in the CONTROL WORD. Using the CONTROL WORD requires that:

- The drive is in remote (REM) control.
- The serial communication channel is defined as the source for controlling commands from EXT1 (set using parameters 1001 EXT1 COMMANDS and 1102 EXT1/EXT2 SEL).
- The external plug-in fieldbus adapter is activated:

- Parameter 9802 COMM PROT SEL = 4 (EXT FBA).
- The external plug-in fieldbus adapter is configured to use the drive profile mode or drive profile objects.

The content of the CONTROL WORD depends on the protocol/profile used. See the user's manual provided with the FBA module and/or the "ABB Drives Profile Technical Data".

Status Word

The STATUS WORD is a 16-bit word containing status information, sent by the drive to the fieldbus controller. The content of the STATUS WORD depends on the protocol/profile used. See the user's manual provided with the FBA module and/or the "ABB Drives Profile Technical Data" section.

Reference

The contents of each REFERENCE word:

- Can be used, as frequency reference.
- Is a 16-bit word comprised of a sign bit and a 15-bit integer.
- Negative references (indicating reversed rotation direction) are indicated by the two's complement of the corresponding positive reference value.

The use of a second reference (REF2) is supported only when a protocol is configured for the ABB Drives profile.

Reference scaling is fieldbus type specific. See the user's manual provided with the FBA module and/or the following sections as appropriate:

- "ABB Drives Profile Technical Data"
- "Generic Profile Technical Data"

Actual Values

Actual Values are 16-bit words containing information on selected operations of the drive. Drive Actual Values (for example, group 01 parameters) can be mapped to Input Words using group 51 parameters (protocol-dependent, but typically parameters 5104...5126).

Planning

Network planning should address the following questions:

- What types and quantities of devices must be connected to the network?
- What control information must be sent down to the drives?
- What feedback information must be sent from the drives to the controlling system?

Mechanical and Electrical Installation – FBA



Warning! Connections should be made only while the drive is disconnected from the power source.

Overview

The FBA (fieldbus adapter) is a plug-in module that fits in the drive's expansion slot 2. The module is held in place with plastic retaining clips and two screws. The screws also ground the shield for the module cable, and connect the module GND signals to the drive control board.

On installation of the module, electrical connection to the drive is automatically established through the 34-pin connector.

Mounting Procedure

Note! Install the input power and motor cables first.

1. Insert the module carefully into the drive expansion slot 2 until the retaining clips lock the module into position.
2. Fasten the two screws (included) to the stand-offs.

Note! Correct installation of the screws is essential for fulfilling the EMC requirements and for proper operation of the module.

3. Open the appropriate knockout in the conduit box and install the cable clamp for the network cable.
4. Route the network cable through the cable clamp.
5. Connect the network cable to the module's network connector.
6. Tighten the cable clamp.
7. Install the conduit box cover (1 screw).
8. For configuration information see the following:
 - "Communication Set-up – FBA" below.
 - "Activate Drive Control Functions – FBA" on page 179.
 - The protocol specific documentation provided with the module.

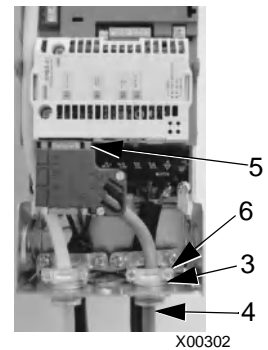
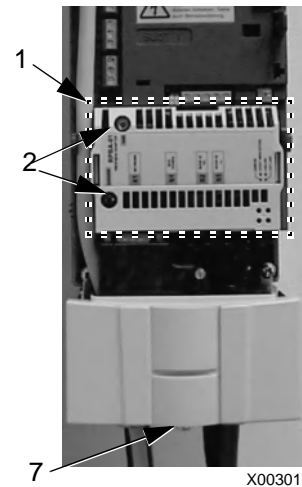

X00301

X00302

Communication Set-up – FBA

Serial Communication Selection

To activate the serial communication, use parameter 9802 COMM PROTOCOL SEL. Set 9802 = 4 (EXT FBA).

Serial Communication Configuration

Setting 9802, together with mounting a particular FBA module, automatically sets the appropriate default values in parameters that define the communication process. These parameters and descriptions are defined in the user's manual supplied with the FBA module.

- Parameter 5101 is automatically configured.
- Parameters 5102...5126 are protocol-dependent and define, for example, the profile used, and additional I/O words. These parameters are referred to as the fieldbus configuration parameters. See the user's manual provided with the FBA module for details on the fieldbus configuration parameters.
- Parameter 5127 forces the validation of changes to parameters 5102...5126. If parameter 5127 is not used, changes to parameters 5102...5126 take affect only after the drive power is cycled.
- Parameters 5128...5133 provide data about the FBA module currently installed (e.g. component versions and status).

The Parameters Description section lists the group 51 parameters.

Activate Drive Control Functions – FBA

Fieldbus control of various drive functions requires configuration to:

- Tell the drive to accept fieldbus control of the function.
- Define as a fieldbus input, any drive data required for control.
- Define as a fieldbus output, any control data required by the drive.

The following sections describe, at a general level, the configuration required for each control function. The last column in each table below is deliberately blank. See the user's manual supplied with the FBA module for the appropriate entry.

Start/Stop Direction Control

Using the fieldbus for start/stop/direction control of the drive requires:

- Drive parameter values set as defined below.
- Fieldbus controller supplied command(s) in the appropriate location. (The location is defined by the Protocol Reference, which is protocol dependent.)

Drive Parameter		Value	Description	Protocol Reference
1001	EXT1 COMMANDS	10 (COMM)	Start/Stop controlled by fieldbus with Ext1 selected.	

Drive Parameter		Value	Description	Protocol Reference
1002	EXT2 COMMANDS	10 (COMM)	Start/Stop by controlled fieldbus with Ext2 selected.	
1003*	DIRECTION	3 (REQUEST)	Direction controlled by fieldbus.	

* This parameter is not available in software option +N688 and +N689.

Input Reference Select

Using the fieldbus to provide input reference to the drive requires:

- Drive parameter value set as defined below.
- Fieldbus controller supplied reference word(s) in the appropriate location. (The location is defined by the Protocol Reference, which is protocol dependent.)

Drive Parameter		Value	Description	Protocol Reference
1102	EXT1/EXT2 SEL	8 (COMM)	Ref. selected by fieldbus. (Required only if 2 references used.)	
1103	REF1 SEL	8 (COMM) 9 (COMM+AI1) 10 (COMM*AI1)	Input reference 1 supplied by fieldbus.	
1106	REF2 SEL	8 (COMM) 9 (COMM+AI) 10 (COMM*AI)	Input reference 2 supplied by fieldbus. (Required only if 2 references used.)	

Note! Multiple references are supported only when using the ABB Drives profile.

Scaling

Where required, REFERENCES can be scaled. See the "Reference Scaling" in the following sections, as appropriate:

- "ABB Drives Profile Technical Data"
- "Generic Profile Technical Data"

System Control

Using the fieldbus for miscellaneous drive control requires:

- Drive parameter values set as defined below.
- Fieldbus controller command(s) in the appropriate location. (The location is defined by the Protocol Reference, which is protocol dependent.)

Drive Parameter		Value	Description	Protocol Reference
1601	RUN ENABLE	7 (COMM)	Run enable by fieldbus.	
1604	FAULT RESET SEL	8 (COMM)	Fault reset by fieldbus.	

Drive Parameter		Value	Description	Protocol Reference
1607	PARAM SAVE	1 (SAVE)	Saves altered parameters to memory (then value returns to 0).	

Relay Output Control

Using the fieldbus for relay output control requires:

- Drive parameter values set as defined below.
- Fieldbus controller supplied, binary coded, relay command(s) in the appropriate location. (The location is defined by the Protocol Reference, which is protocol dependent.)

Drive Parameter		Value	Description	Protocol Reference
1401	RELAY OUTPUT 1	35 (COMM)	Relay Output 1 controlled by fieldbus.	
1402	RELAY OUTPUT 2	36 (COMM(-1))	Relay Output 2 controlled by fieldbus.	
1403	RELAY OUTPUT 3		Relay Output 3 controlled by fieldbus.	
1410 ¹	RELAY OUTPUT 4		Relay Output 4 controlled by fieldbus.	
1411 ¹	RELAY OUTPUT 5		Relay Output 5 controlled by fieldbus.	
1412 ¹	RELAY OUTPUT 6		Relay Output 6 controlled by fieldbus.	

1. More than 3 relays requires the addition of a relay extension module.

Note! Relay status feedback occurs without configuration as defined below.

Drive Parameter		Value	Protocol Reference
0122	RO 1-3 STATUS	Relay 1...3 status.	
0123	RO 4-6 STATUS	Relay 4...6 status.	

Analog Output Control

Using the fieldbus for analog output control (e.g. PID setpoint) requires:

- Drive parameter values set as defined below.
- Fieldbus controller supplied analog value(s) in the appropriate location. (The location is defined by the Protocol Reference, which is protocol dependent.)

Drive Parameter		Value	Description	Protocol Reference
1501	AO1 CONTENT SEL	135 (COMM VALUE 1)	Analog Output 1 controlled by writing to parameter 0135.	–
0135	COMM VALUE 1	–		
1502 ... 1505	AO1 CONTENT MIN ... MAXIMUM AO1	Set appropriate values.	Used for scaling	–
1506	FILTER AO1		Filter time constant for AO1.	–
1507	AO2 CONTENT SEL	136 (COMM VALUE 2)	Analog Output 2 controlled by writing to parameter 0136.	–
0136	COMM VALUE 2	–		

Drive Parameter		Value	Description	Protocol Reference
1508	AO2 CONTENT MIN	Set appropriate values.	Used for scaling	–
...	...			
1511	MAXIMUM AO2			
1512	FILTER AO2		Filter time constant for AO2.	–

PID Control Setpoint Source

Using the following settings to select the fieldbus as the setpoint source for PID loops:

Drive Parameter		Value	Setting	Protocol Reference
4010	SET POINT SEL (Set 1)	8 (COMM VALUE 1)	Setpoint is input reference 2 (+/-* AI1)	
4110	SET POINT SEL (Set 2)	9 (COMM + AI1)		
4210	SET POINT SEL (Ext/Trim)	10 (COMM*AI1)		

Communication Fault

When using fieldbus control, specify the drive's action if serial communication is lost.

Drive Parameter		Value	Description
3018	COMM FAULT FUNC	0 (NOT SEL) 1 (FAULT) 2 (CONST SP7) 3 (LAST SPEED)	Set for appropriate drive response.
3019	COMM FAULT TIME	Set time delay before acting on a communication loss.	

Feedback from the Drive – FBA

Inputs to the controller (drive outputs) have pre-defined meanings established by the protocol. This feedback does not require drive configuration. The following table lists a sample of feedback data. For a complete listing, see all parameters listed in "Complete Parameter Descriptions".

Drive Parameter		Protocol Reference
0102	SPEED	
0103	OUTPUT FREQ	
0104	CURRENT	
0105	TORQUE	
0106	POWER	
0107	DC BUS VOLTAGE	
0109	OUTPUT VOLTAGE	
0301	FB CMD WORD 1 – bit 0 (STOP)	
0301	FB CMD WORD 1 – bit 2 (REV)	
0118	DI 1-3 STATUS – bit 0 (DI3)	

Scaling

To scale the drive parameter values see the "Actual Value Scaling" in the following sections, as appropriate:

- "ABB Drives Profile Technical Data"
- "Generic Profile Technical Data"

Diagnostics – FBA

Fault Handling

The ACS510 provides fault information as follows:

- The control panel display shows a fault code and text. See "Diagnostics" starting on page 196 for a complete description.
- Parameters 0401 LAST FAULT, 0402 PREVIOUS FAULT1 and 0403 PREVIOUS FAULT2 store the most recent faults.
- For fieldbus access, the drive reports faults as a hexadecimal value, assigned and coded according to the DRIVECOM specification. See table below. Not all profiles support requesting fault codes using this specification. For profiles that support this specification, the profile documentation defines the proper fault request process.

	Drive Fault Code	Fieldbus Fault Code (DRIVECOM specification)
1	OVERCURRENT	2310h
2	DC OVERVOLT	3210h
3	DEV OVERTEMP	4210h
4	SHORT CIRC	2340h
5	Reserved	FF6Bh
6	DC UNDERVOLT	3220h
7	AI1 LOSS	8110h
8	AI2 LOSS	8110h
9	MOT OVERTEMP	4310h
10	PANEL LOSS	5300h
11	NOT USED	
12	MOTOR STALL	7121h
14	EXT FAULT 1	9000h
15	EXT FAULT 2	9001h
16	EARTH FAULT	2330h
17	Obsolete	FF6Ah
18	THERM FAIL	5210h
19	OPEX LINK	7500h
20	OPEX PWR	5414h
21	CURR MEAS	2211h

Drive Fault Code		Fieldbus Fault Code (DRIVECOM specification)
22	SUPPLY PHASE	3130h
23	NOT USED	
24	NOT USED	
25	Reserved	FF80h
26	DRIVE ID	5400h
27	CONFIG FILE	630Fh
28	SERIAL 1 ERR	7510h
29	EFB CON FILE	6306h
30	FORCE TRIP	FF90h
31	EFB 1	FF92h
32	EFB 2	FF93h
33	EFB 3	FF94h
34	MOTOR PHASE	FF56h
35	OUTPUT WIRING	FF95h
36	INCOMPATIBLE SW	630Fh
37	CB OVERTEMP	4110h
38	USER LOAD CURVE	FF6Bh
101	SERF CORRUPT	FF55h
102	Reserved	FF55h
103	SERF MACRO	FF55h
104	Reserved	FF55h
105	Reserved	FF55h
201	DSP T1 OVERLOAD	6100h
202	DSP T2 OVERLOAD	6100h
203	DSP T3 OVERLOAD	6100h
204	DSP STACK ERROR	6100h
205	Reserved (obsolete)	5000h
206	CB ID ERROR	5000h
207	EFB LOAD ERR	6100h
1000	PAR HZRPM	6320h
1001	PAR PFC REF NEG	6320h
1002	Reserved (obsolete)	6320h
1003	PAR AI SCALE	6320h
1004	PAR AO SCALE	6320h
1005	PAR PCU 2	6320h
1006	PAR EXT RO	6320h
1007	PAR FIELDBUS MISSING	6320h
1008	PAR PFC MODE	6320h

Drive Fault Code		Fieldbus Fault Code (DRIVECOM specification)
1009	PAR PCU 1	6320h
1012	PAR PFC IO 1	6320h
1013	PAR PFC IO 2	6320h
1014	PAR PFC IO 3	6320h
1016	PAR USER LOAD C	6320h

Serial Communication Diagnostics

Besides the drive fault codes, the FBA module has diagnostic tools. Refer to the user's manual supplied with the FBA module.

ABB Drives Profile Technical Data

Overview

The ABB Drives profile provides a standard profile that can be used on multiple protocols, including protocols available on the FBA module. This section describes the ABB Drives profile implemented for FBA modules.

Control Word

As described earlier in "Control Interface" the CONTROL WORD is the principal means for controlling the drive from a fieldbus system.

The following table and the state diagram later in this sub-section describe the CONTROL WORD content for the ABB Drives profile.

ABB Drives Profile (FBA) CONTROL WORD				
Bit	Name	Value	Commanded State	Comments
0	OFF1 CONTROL	1	READY TO OPERATE	Enter READY TO OPERATE
		0	EMERGENCY OFF	Drive ramps to stop according to currently active deceleration ramp (2203 or 2205) Normal command sequence: <ul style="list-style-type: none"> • Enter OFF1 ACTIVE • Proceed to READY TO SWITCH ON, unless other interlocks (OFF2, OFF3) are active.
1	OFF2 CONTROL	1	OPERATING	Continue operation (OFF2 inactive)
		0	EMERGENCY OFF	Drive coasts to stop. Normal command sequence: <ul style="list-style-type: none"> • Enter OFF2 ACTIVE • Proceed to SWITCHON INHIBITED
2	OFF3 CONTROL	1	OPERATING	Continue operation (OFF3 inactive)
		0	EMERGENCY STOP	Drive stops within in time specified by parameter 2208. Normal command sequence: <ul style="list-style-type: none"> • Enter OFF3 ACTIVE • Proceed to SWITCH ON INHIBITED WARNING! Be sure motor and driven equipment can be stopped using this mode.
3	INHIBIT OPERATION	1	OPERATION ENABLED	Enter OPERATION ENABLED (Note the Run enable signal must be active. See 1601. If 1601 is set to COMM, this bit also activates the Run Enable signal.)
		0	OPERATION INHIBITED	Inhibit operation. Enter OPERATION INHIBITED
4	RAMP_OUT_ZERO	1	NORMAL OPERATION	Enter RAMP FUNCTION GENERATOR: ACCELERATION ENABLED
		0	RFG OUT ZERO	Force ramp function generator output to Zero. Drive ramps to stop (current and DC voltage limits in force).

ABB Drives Profile (FBA) CONTROL WORD				
Bit	Name	Value	Commanded State	Comments
5	RAMP_HOLD	1	RFG OUT ENABLED	Enable ramp function. Enter RAMP FUNCTION GENERATOR: ACCELERATOR ENABLED
		0	RFG OUT HOLD	Halt ramping (Ramp Function Generator output held)
6	RAMP_IN_ZERO	1	RFG INPUT ENABLED	Normal operation. Enter OPERATING
		0	RFG INPUT ZERO	Force Ramp Function Generator input to zero.
7	RESET	0=>1	RESET	Fault reset if an active fault exists (Enter SWITCH-ON INHIBITED). Effective if 1604 = COMM.
		0	OPERATING	Continue normal operation
8...9	Unused			
10	REMOTE_CMD	1		Fieldbus control enabled
		0		<ul style="list-style-type: none"> CW ≠ 0 or Ref ≠ 0: Retain last CW and Ref. CW = 0 and Ref = 0: Fieldbus control enabled. Ref and deceleration/acceleration ramp are locked.
11	EXT CTRL LOC	1	EXT2 SELECT	Select external control location 2 (EXT2). Effective if 1102 = COMM.
		0	EXT1 SELECT	Select external control location 1 (EXT1). Effective if 1102 = COMM.
12...15	Unused			

Status Word

As described earlier in "Control Interface", the contents of the STATUS WORD is status information, sent by the drive to the master station. The following table and the state diagram later in this sub-section describe the status word content.

ABB Drives Profile (FBA) STATUS WORD			
Bit	Name	Value	Description (Correspond to states/boxes in the state diagram)
0	RDY_ON	1	READY TO SWITCH ON
		0	NOT READY TO SWITCH ON
1	RDY_RUN	1	READY TO OPERATE
		0	OFF1 ACTIVE
2	RDY_REF	1	OPERATION ENABLED
		0	OPERATION INHIBITED
3	TRIPPED	0...1	FAULT
		0	No fault

ABB Drives Profile (FBA) STATUS WORD			
Bit	Name	Value	Description (Correspond to states/boxes in the state diagram)
4	OFF_2_STA	1	OFF2 inactive
		0	OFF2 ACTIVE
5	OFF_3_STA	1	OFF3 inactive
		0	OFF3 ACTIVE
6	SWC_ON_INHIB	1	SWITCH-ON INHIBIT ACTIVE
		0	SWITCH-ON INHIBIT NOT ACTIVE
7	ALARM	1	Warning/alarm (See "Alarm Listing" in the "Diagnostics" section for details on alarms.)
		0	No warning/alarm
8	AT_SETPOINT	1	OPERATING. Actual value equals (within tolerance limits) the reference value.
		0	Actual value is outside tolerance limits (not equal to reference value).
9	REMOTE	1	Drive control location: REMOTE (EXT1 or EXT2)
		0	Drive control location: LOCAL
10	ABOVE_LIMIT	1	Supervised parameter's value \geq supervision high limit. Bit remains "1" until supervised parameter's value < supervision low limit. See group 32, Supervision
		0	Supervised parameter's value < supervision low limit. Bit remains "0" until supervised parameter's value > supervision high limit. See group 32, Supervision
11	EXT CTRL LOC	1	External control location 2 (EXT2) selected
		0	External control location 1 (EXT1) selected
12	EXT RUN ENABLE	1	External Run Enable signal received
		0	No External Run Enable signal received
13... 15	Unused		

The state diagram below describes the start-stop function of CONTROL WORD (CW) and STATUS WORD (SW) bits.

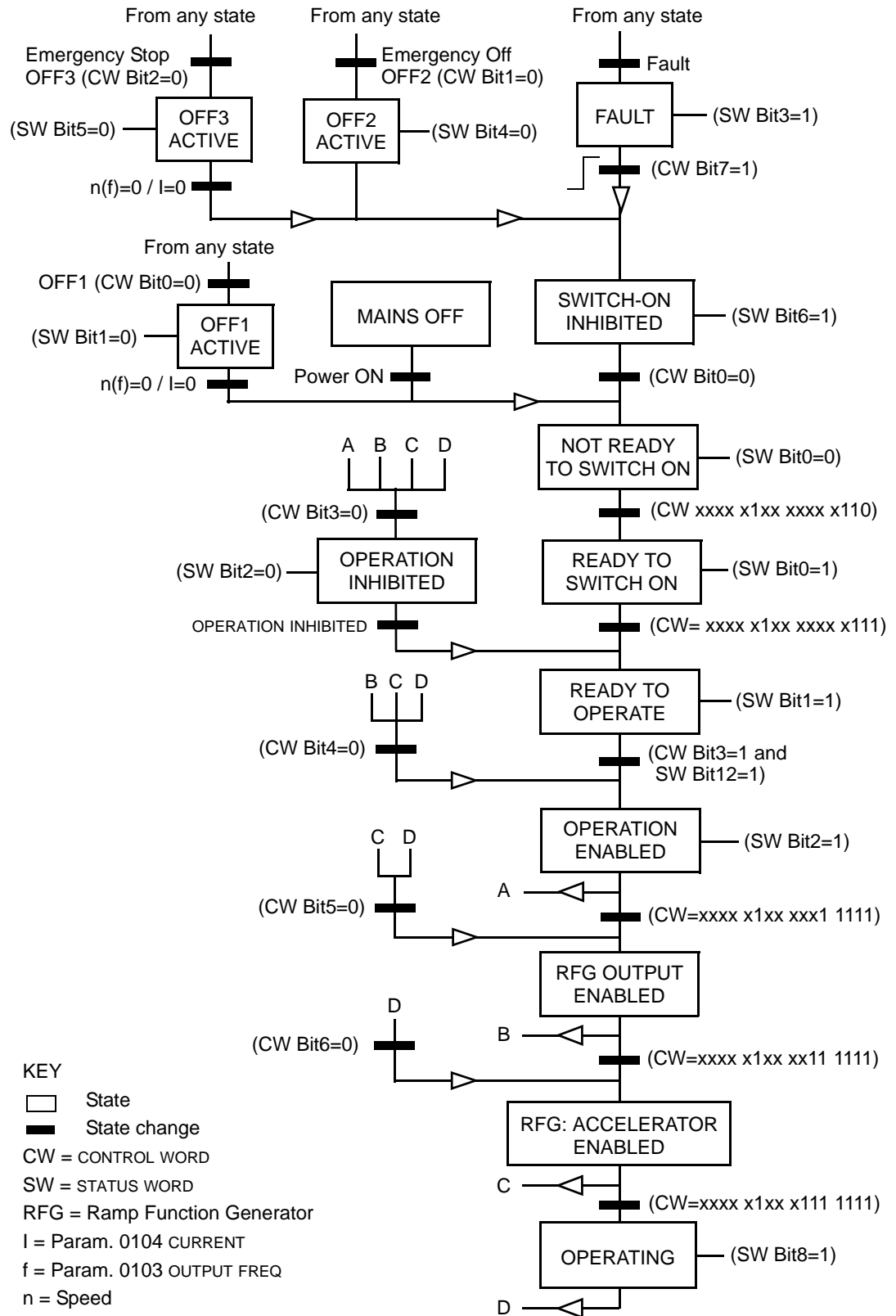

Reference

As described earlier in "Control Interface", the REFERENCE word is a [frequency](#) reference.

Reference Scaling

The following table describes REFERENCE scaling for the ABB Drives profile.

ABB Drives Profile (FBA)				
Reference	Range	Reference Type	Scaling	Remarks
REF1	-32767... +32767	Frequency	-20000 = -(par. 1105) 0 = 0 +20000 = (par. 1105) (20000 corresponds to 100%)	Final reference limited by 1104/1105. Actual motor speed limited by 2007/2008 (frequency).
REF2	-32767... +32767	Frequency	-10000 = -(par. 1108) 0 = 0 +10000 = (par. 1108) (10000 corresponds to 100%)	Final reference limited by 1107/1108. Actual motor speed limited by 2007/2008 (frequency).
		PID Reference	-10000 = -(par. 1108) 0 = 0 +10000 = (par. 1108) (10000 corresponds to 100%)	Final reference limited by 4012/4013 (PID set1) or 4112/4113 (PID set2).

Note! The setting of parameter 1104 REF1 MIN and 1107 REF2 MIN has no effect on the scaling of references.

When parameter 1103 REF1 SELECT or 1106 REF2 SELECT is set to COMM+AI1 or COMM*AI1, the reference is scaled as follows:

ABB Drives Profile (FBA)		
Reference	Value Setting	AI Reference Scaling
REF1	COMM+AI1	$\text{COMM (\%)} + (\text{AI (\%)} - 0.5 \cdot \text{REF1 MAX (\%)})$

ABB Drives Profile (FBA)		
Reference	Value Setting	AI Reference Scaling
REF1	COMM*AI1	$\text{COMM (\%)} * (\text{AI (\%)} / 0.5 * \text{REF1 MAX (\%)})$
REF2	COMM+AI1	$\text{COMM (\%)} + (\text{AI (\%)} - 0.5 * \text{REF2 MAX (\%)})$
REF2	COMM*AI1	$\text{COMM (\%)} * (\text{AI (\%)} / 0.5 * \text{REF2 MAX (\%)})$

Reference Handling

Use group 10 parameters to configure for control of rotation direction for each control location (EXT1 and EXT2). The following diagrams illustrate how group 10 parameters and the sign of the fieldbus reference interact to produce REFERENCE values (REF1 and REF2). Note, fieldbus references are bipolar, that is they can be positive or negative.

ABB Drives Profile		
Parameter	Value Setting	AI Reference Scaling
1003 DIRECTION*	1 (FORWARD)	
1003 DIRECTION*	2 (REVERSE)	
1003 DIRECTION*	3 (REQUEST)	

* This parameter is not available in software option +N688 and +N689.

Actual Value

As described earlier in "Control Interface", Actual Values are words containing drive values.

Actual Value Scaling

The scaling of the integers sent to the fieldbus as Actual Values depends on the resolution of the selected drive parameter. Except as noted for Data Words 5 and 6 below, scale the feedback integer using the resolution listed for the parameter in the "Complete Parameter List for ACS510" section. For example:

Feedback Integer	Parameter Resolution	Scaled Value
1	0.1 mA	$1 * 0.1 \text{ mA} = 0.1 \text{ mA}$
10	0.1%	$10 * 0.1\% = 1\%$

Data words 5 and 6 are scaled as follows:

ABB Drives Profile		
Data Word	Contents	Scaling
ACT1	ACTUAL SPEED	$-20000 \dots +20000 = -(\text{par. 1105}) \dots +(\text{par. 1105})$
ACT2	TORQUE	$-10000 \dots +10000 = -100\% \dots +100\%$

Actual Value Mapping

See the user's manual supplied with the FBA module.

Generic Profile Technical Data

Overview

The generic profile aims to fulfill the industry-standard drive profile for each protocol (e.g. PROFIdrive for PROFIBUS, AC/DC Drive for DeviceNet).

Control Word

As described earlier in "Control Interface" the CONTROL WORD is the principal means for controlling the drive from a fieldbus system. For specific CONTROL WORD content, see the user's manual provided with the FBA module.

Status Word

As described earlier in "Control Interface", the contents of the STATUS WORD is status information, sent by the drive to the master station. For specific STATUS WORD content, see the user's manual provided with the FBA module.

Reference

As described earlier in "Control Interface", the REFERENCE word is a frequency reference.

Note! REF2 is not supported by the Generic Drive profiles.

Reference Scaling

REFERENCE scaling is fieldbus type specific. However, at the drive, the meaning of a 100% REFERENCE value is fixed as described in the table below. For a detailed description on the range and scaling of the REFERENCE, see the user's manual supplied with the FBA module.

Generic Profile				
Reference	Range	Reference Type	Scaling	Remarks
REF	Fieldbus specific	Frequency	-100% = -(par. 9907) 0 = 0 +100 = (par. 9907)	Final reference limited by 1104/1105. Actual motor speed limited by 2007/2008 (frequency).

Actual Values

As described earlier in "Control Interface", Actual Values are words containing drive values.

Actual Value Scaling

For Actual Values, scale the feedback integer using the parameter's resolution. (See "Complete Parameter List for ACS510" section for parameter resolutions.) For example:

Feedback Integer	Parameter Resolution	(Feedback Integer) * (Parameter Resolution) = Scaled Value
1	0.1 mA	1 * 0.1 mA = 0.1 mA
10	0.1%	10 * 0.1% = 1%

Where parameters are in percent, the "Complete Parameter List for ACS510" section specifies what parameter corresponds to 100%. In such cases, to convert from percent to engineering units, multiply by the value of the parameter that defines 100% and divide by 100%. For example:

Feedback Integer	Parameter Resolution	Value of the Parameter that defines 100%	(Feedback Integer) * (Parameter Resolution) * (Value of 100% Ref.) / 100% = Scaled Value
10	0.1%	1500 rpm ¹	10 * 0.1% * 1500 RPM / 100% = 15 rpm
100	0.1%	500 Hz ²	100 * 0.1% * 500 Hz / 100% = 50 Hz

1. Assuming, for the sake of this example, that the Actual Value uses parameter 9908 MOT NOM SPEED as the 100% reference, and that 9908 = 1500 rpm.
2. Assuming, for the sake of this example, that the Actual Value uses parameter 9907 MOT NOM FREQ as the 100% reference, and that 9907 = 500 Hz.

Actual Value Mapping

See the user's manual supplied with the FBA module.

Diagnostics



Warning! Do not attempt any measurement, parts replacement or other service procedure not described in this manual. Such action will void the warranty, may endanger correct operation, and increase downtime and expense.



Warning! All electrical installation and maintenance work described in this chapter should only be undertaken by qualified service personnel. The Safety instructions on the first pages of this manual must be followed.

Diagnostic Displays

The drive detects error situations and reports them using:

- The green and red LED on the body of the drive
- The status LED on the control panel (if an Assistant control panel is attached to the drive)
- The control panel display (if a control panel is attached to the drive)
- The Fault Word and Alarm Word parameter bits (parameters 0305 to 0309). See "Group 03: FB Actual Signals" on page 69 for the bit definitions.

The form of the display depends on the severity of the error. You can specify the severity for many errors by directing the drive to:

- Ignore the error situation.
- Report the situation as an alarm.
- Report the situation as a fault.

Red – Faults

The drive signals that it has detected a severe error, or fault, by:

- Enabling the red LED on the drive (LED is either steady on or blinking).
- Showing the steady red status LED on the control panel (if attached to the drive).
- Setting an appropriate bit in a Fault Word parameter (0305 to 0307).
- Overriding the control panel display with the display of a fault code.
- Stopping the motor (if it was on).

The fault code on the control panel display is temporary. Pressing any of the following keys removes the fault message: MENU, ENTER, UP button, or DOWN key. The message reappears after a few seconds if the control panel is not touched and the fault is still active.

Flashing Green – Alarms

For less severe errors, called alarms, the diagnostic display is advisory. For these situations, the drive is simply reporting that it had detected something “unusual.” In these situations, the drive:

- Flashes the green LED on the drive (does not apply to alarms that arise from control panel operation errors).
- Flashes the green LED on the control panel (if attached to the drive).
- Sets an appropriate bit in an Alarm Word parameter (0308 or 0309). See "Group 03: FB Actual Signals" on page 69 for the bit definitions.
- Overrides the control panel display with the display of an alarm code and/or name.

Alarm messages disappear from the control panel display after a few seconds. The message returns periodically as long as the alarm condition exists.

Correcting Faults

The recommended corrective action for faults is:

- Use the "Fault Listing" table below to find and address the root cause of the problem.
- Reset the drive. See "Fault Resetting" on page 201.

Fault Listing

Fault Code	Fault Name In Panel	Description and Recommended Corrective Action
1	OVERCURRENT	Output current is excessive. Check for and correct: <ul style="list-style-type: none"> • Excessive motor load. • Insufficient acceleration time (parameters 2202 ACCELER TIME 1 and 2205 ACCELER TIME 2). • Faulty motor, motor cables or connections.
2	DC OVERVOLT	Intermediate circuit DC voltage is excessive. Check for and correct: <ul style="list-style-type: none"> • Static or transient overvoltages in the input power supply. • Insufficient deceleration time (parameters 2203 DECELER TIME 1 and 2206 DECELER TIME 2). • Undersized brake chopper (if present). • Verify that overvoltage controller is ON (using parameter 2005).
3	DEV OVERTEMP	Drive heatsink is overheated. Temperature is at or above limit. R1...R4 : 115 °C (239 °F) R5/R6: 125 °C (257 °F) Check for and correct: <ul style="list-style-type: none"> • Fan failure. • Obstructions in the air flow. • Dirt or dust coating on the heat sink. • Excessive ambient temperature. • Excessive motor load.

Fault Code	Fault Name In Panel	Description and Recommended Corrective Action
4	SHORT CIRC	Fault current. Check for and correct: <ul style="list-style-type: none"> • A short-circuit in the motor cable(s) or motor. • Supply disturbances.
5	REVERSED	Not used.
6	DC UNDERVOLT	Intermediate circuit DC voltage is not sufficient. Check for and correct: <ul style="list-style-type: none"> • Missing phase in the input power supply. • Blown fuse. • Undervoltage on mains.
7	AI1 LOSS	Analog input 1 loss. Analog input value is less than AI1FAULT LIMIT (3021). Check for and correct: <ul style="list-style-type: none"> • Source and connection for analog input. • Parameter settings for AI1FAULT LIMIT (3021) and 3001 AI<MIN FUNCTION.
8	AI2 LOSS	Analog input 2 loss. Analog input value is less than AI2 FAULT LIMIT (3022). Check for and correct: <ul style="list-style-type: none"> • Source and connection for analog input. • Parameter settings for AI2 FAULT LIMIT (3022) and 3001 AI<MIN FUNCTION.
9	MOT OVERTEMP	Motor is too hot, based on either the drive's estimate or on temperature feedback. <ul style="list-style-type: none"> • Check for overloaded motor. • Adjust the parameters used for the estimate (3005...3009). • Check the temperature sensors and Group 35 parameters.
10	PANEL LOSS	Panel communication is lost and either: <ul style="list-style-type: none"> • Drive is in local control mode (the control panel displays LOC), or • Drive is in remote control mode (REM) and is parameterized to accept start/stop, direction or reference from the control panel. To correct check: <ul style="list-style-type: none"> • Communication lines and connections • Parameter 3002 PANEL COMM ERR. • Parameters in Group 10: Command Inputs and Group 11: Reference Select (if drive operation is REM).
11	REVERSED	Not used.
12	MOTOR STALL	Motor or process stall. Motor is operating in the stall region. Check for and correct: <ul style="list-style-type: none"> • Excessive load. • Insufficient motor power. • Parameters 3010...3012.
13	RESERVED	Not used.
14	EXT FAULT 1	Digital input defined to report first external fault is active. See parameter 3003 EXTERNAL FAULT 1.
15	EXT FAULT 2	Digital input defined to report second external fault is active. See parameter 3004 EXTERNAL FAULT 2.

Fault Code	Fault Name In Panel	Description and Recommended Corrective Action
16	EARTH FAULT	Possible ground fault detected in the motor or motor cables. The drive monitors for ground faults while the drive is running and while the drive is not running. Detection is more sensitive when the drive is not running and can produce false positives. Possible corrections: <ul style="list-style-type: none"> • Check for/correct faults in the input wiring. • Verify that motor cable does not exceed maximum specified length. • A delta grounded input power supply and motor cables with high capacitance may result in erroneous error reports during non-running tests. To disable response to fault monitoring when the drive is not running, use parameter 3023 WIRING FAULT. To disable response to all ground fault monitoring, use parameter 3017 EARTH FAULT.
17	RESERVED	
18	THERM FAIL	Internal fault. The thermistor measuring the internal temperature of the drive is open or shorted. Contact your local ABB representative.
19	OPEX LINK	Internal fault. A communication-related problem has been detected on the fiber optic link between the control and OINT boards. Contact your local ABB sales representative.
20	OPEX PWR	Internal fault. Low voltage condition detected on OINT power supply. Contact your local ABB representative.
21	CURR MEAS	Internal fault. Current measurement is out of range. Contact your local ABB representative.
22	SUPPLY PHASE	Ripple voltage in the DC link is too high. Check for and correct: <ul style="list-style-type: none"> • Missing mains phase. • Blown fuse.
23	If this error code appears, refer to the appropriate accessory manual.	
24	RESERVED	Not used.
25	RESERVED	Not used.
26	DRIVE ID	Internal fault. Configuration Block Drive ID is not valid. Contact your local ABB sales representative.
27	CONFIG FILE	Internal configuration file has an error. Contact your local ABB sales representative.
28	SERIAL 1 ERR	Fieldbus communication has timed out. Check for and correct: <ul style="list-style-type: none"> • Fault setup (3018 COMM FAULT FUNC and 3019 COMM FAULT TIME). • Communication settings (Group 51 or 53 as appropriate). • Poor connections and/or noise on line.
29	EFB CON FILE	Error in reading the configuration file for the embedded fieldbus.
30	FORCE TRIP	Fault trip forced by the fieldbus. See the fieldbus User's Manual.
31	EFB 1	Fault code reserved for the embedded fieldbus (EFB) protocol application. The meaning is protocol dependent.
32	EFB 2	
33	EFB 3	
34	MOTOR PHASE	Fault in the motor circuit. One of the motor phases is lost. Check for and correct: <ul style="list-style-type: none"> • Motor fault. • Motor cable fault. • Thermal relay fault (if used). • Internal fault.

Fault Code	Fault Name In Panel	Description and Recommended Corrective Action
35	OUTPUT WIRING	Possible power wiring error detected. When the drive is not running it monitors for an improper connection between the drive input power and the drive output. Check for and correct: <ul style="list-style-type: none"> • Proper input wiring – line voltage is NOT connected to drive output. • The fault can be erroneously declared if the input power is a delta grounded system and motor cable capacitance is large. This fault can be disabled using parameter 3023 WIRING FAULT.
36	INCOMPATIBLE SW	The drive cannot use the software. <ul style="list-style-type: none"> • Internal Fault. • The loaded software is not compatible with the drive. • Call support representative.
37	CB OVERTEMP	Drive control board is overheated. The fault trip limit is 88 °C. Check for and correct: <ul style="list-style-type: none"> • Excessive ambient temperature. • Fan failure. • Obstructions in the air flow. Not for drives with an OMIO control board.
38	USER LOAD CURVE	Condition defined by parameter 3701 USER LOAD C MODE has been valid longer than the time defined by 3703 USER LOAD C TIME.
101... 199	SYSTEM ERROR	Error internal to the drive. Contact your local ABB representative and report the error number.
201... 299	SYSTEM ERROR	Error in the system. Contact your local ABB representative and report the error number.

Faults that indicate conflicts in the parameter settings are listed below.

Fault Code	Fault Name In Panel	Description and Recommended Corrective Action
1000	PAR HZRPM	Parameter values are inconsistent. Check for any of the following: <ul style="list-style-type: none"> • 2007 MINIMUM FREQ > 2008 MAXIMUM FREQ. • 2007 MINIMUM FREQ / 9907 MOTOR NOM FREQ is outside proper range (> 50) • 2008 MAXIMUM FREQ / 9907 MOTOR NOM FREQ is outside proper range (> 50)
1001	PAR PFC REF NEG	Parameter values are inconsistent. Check for the following: <ul style="list-style-type: none"> • 2007 MINIMUM FREQ is negative, when 8123 PFC ENABLE is active.
1003	PAR AI SCALE	Parameter values are inconsistent. Check for any of the following: <ul style="list-style-type: none"> • 1301 AI1 MIN > 1302 AI1 MAX. • 1304 AI2 MIN > 1305 AI2 MAX.
1004	PAR AO SCALE	Parameter values are inconsistent. Check for any of the following: <ul style="list-style-type: none"> • 1504 AO1 MIN > 1505 AO1 MAX. • 1510 AO2 MIN > 1511 AO2 MAX.
1005	PAR PCU 2	Parameter values for power control are inconsistent: Improper motor nominal kVA or motor nominal power. Check for the following: <ul style="list-style-type: none"> • $1.1 \leq (9906 \text{ MOTOR NOM CURR} * 9905 \text{ MOTOR NOM VOLT} * 1.73 / P_N) \leq 3.0$ • where: $P_N = 1000 * 9909 \text{ MOTOR NOM POWER}$ (if units are kW) or $P_N = 746 * 9909 \text{ MOTOR NOM POWER}$ (if units are HP, e.g. in US)

Fault Code	Fault Name In Panel	Description and Recommended Corrective Action
1006	PAR EXT RO	Parameter values are inconsistent. Check for the following: <ul style="list-style-type: none"> • Extension relay module not connected and • 1410...1412 RELAY OUTPUTS 4...6 have non-zero values.
1007	PAR FIELD BUS MISSING	Parameter values are inconsistent. Check for and correct: <ul style="list-style-type: none"> • A parameter is set for fieldbus control (e.g. 1001 EXT1 COMMANDS = 10 (COMM)), but 9802 COMM PROT SEL = 0.
1008	REVERSED	
1009	PAR PCU 1	Parameter values for power control are inconsistent: Improper motor nominal frequency or speed. Check for both of the following: <ul style="list-style-type: none"> • $1 \leq (60 * 9907 \text{ MOTOR NOM FREQ} / 9908 \text{ MOTOR NOM SPEED}) \leq 16$ • $0.8 \leq 9908 \text{ MOTOR NOM SPEED} / (120 * 9907 \text{ MOTOR NOM FREQ} / \text{Motor Poles}) \leq 0.992$
1011	PAR OVERRIDE	See Parameter Group 17.
1012	PAR PFC IO 1	IO configuration is not complete – not enough relays are parameterized to PFC. Or, a conflict exists between Group 14, parameter 8117, NR OF AUX MOT, and parameter 8118, AUTOCHNG INTERV.
1013	PAR PFC IO 2	IO configuration is not complete – the actual number of PFC motors (parameter 8127, MOTORS) does not match the PFC motors in Group 14 and parameter 8118 AUTOCHNG INTERV.
1014	PAR PFC IO 3	IO configuration is not complete – the drive is unable to allocate a digital input (interlock) for each PFC motor (parameters 8120 INTERLOCKS and 8127 MOTORS).
1015	PAR USER DEFINED U/F	The user defined U/f ratio is not compatibility (only when parameters 2605 = 3).
1016	PAR USER LOAD C	See Parameter Group 37.

Fault Resetting

The ACS510 can be configured to automatically reset certain faults. Refer to parameter Group 31: Automatic Reset.



Warning! If an external source for start command is selected and it is active, the ACS510 may start immediately after fault reset.

Flashing Red LED

To reset the drive for faults indicated by a flashing red LED:

- Turn the power off for 5 minutes.

Red LED

To reset the drive for faults indicated by a red LED (on, not flashing), correct the problem and do one of the following:

- From the control panel: Press RESET
- Turn the power off for 5 minutes.

Depending on the value of 1604, FAULT RESET SELECT, the following could also be used to reset the drive:

- Digital input
- Serial communication

When the fault has been corrected, the motor can be started.

History

For reference, the last three fault codes are stored into parameters 0401, 0412, 0413. For the most recent fault (identified by parameter 0401), the drive stores additional data (in parameters 0402...0411) to aid in troubleshooting a problem. For example, parameter 0404 stores the motor speed at the time of the fault.

To clear the fault history (all of the Group 04, Fault History parameters):

1. Using the control panel in Parameters mode, select parameter 0401.
2. Press EDIT (or ENTER on the Basic Control Panel).
3. Press UP and DOWN at the same time.
4. Press SAVE.

Correcting Alarms

The recommended corrective action for alarms is:

- Determine if the Alarm requires any corrective action (action is not always required).
- Use "Alarm Listing" below to find and address the root cause of the problem.

Alarm Listing

The following table lists the alarms by code number and describes each.

Alarm Code	Display	Description
2001	OVERCURRENT	Current limiting controller is active. Check for and correct: <ul style="list-style-type: none"> Excessive motor load. Insufficient acceleration time (parameters 2202 ACCELER TIME 1 and 2205 ACCELER TIME 2). Faulty motor, motor cables or connections.
2002	OVERVOLTAGE	Overvoltage controller is active. Check for and correct: <ul style="list-style-type: none"> Static or transient overvoltages in the input power supply. Insufficient deceleration time (parameters 2203 DECELER TIME 1 and 2206 DECELER TIME 2).
2003	UNDERVOLTAGE	Undervoltage controller is active. Check for and correct: <ul style="list-style-type: none"> Undervoltage on mains.
2004	DIR LOCK	The change in direction being attempted is not allowed. Either: <ul style="list-style-type: none"> Do not attempt to change the direction of motor rotation, or Change parameter 1003 DIRECTION to allow direction change (if reverse operation is safe).
2005	I/O COMM	Fieldbus communication has timed out. Check for and correct: <ul style="list-style-type: none"> Fault setup (3018 COMM FAULT FUNC and 3019 COMM FAULT TIME). Communication settings (Group 51 or 53 as appropriate). Poor connections and/or noise on line.
2006	AI1 LOSS	Analog input 1 is lost, or value is less than the minimum setting. Check: <ul style="list-style-type: none"> Input source and connections Parameter that sets the minimum (3021) Parameter that sets the Alarm/Fault operation (3001)
2007	AI2 LOSS	Analog input 2 is lost, or value is less than the minimum setting. Check: <ul style="list-style-type: none"> Input source and connections Parameter that sets the minimum (3022) Parameter that sets the Alarm/Fault operation (3001)
2008	PANEL LOSS	Panel communication is lost and either: <ul style="list-style-type: none"> Drive is in local control mode (the control panel displays LOC), or Drive is in remote control mode (REM) and is parameterized to accept start/stop, direction or reference from the control panel. To correct check: <ul style="list-style-type: none"> Communication lines and connections Parameter 3002 PANEL COMM ERR. Parameters in groups 10 COMMAND INPUTS and 11 REFERENCE SELECT (if drive operation is REM).

Alarm Code	Display	Description
2009	DEVICE OVERTEMP	Drive heatsink is hot. This alarm warns that a DEVICE OVERTEMP fault may be near. R1...R4 & R7/R8: 100 °C (212 °F) R5/R6: 110 °C (230 °F) Check for and correct: <ul style="list-style-type: none"> • Fan failure. • Obstructions in the air flow. • Dirt or dust coating on the heat sink. • Excessive ambient temperature. • Excessive motor load.
2010	MOTOR TEMP	Motor is hot, based on either the drive's estimate or on temperature feedback. This alarm warns that a Mot Overtemp fault trip may be near. Check: <ul style="list-style-type: none"> • Check for overloaded motor. • Adjust the parameters used for the estimate (3005...3009). • Check the temperature sensors and Group 35 parameters.
2011	RESERVED	
2012	MOTOR STALL	Motor is operating in the stall region. This alarm warns that a Motor Stall fault trip may be near.
2013 (note 1)	AUTORESET	This alarm warns that the drive is about to perform an automatic fault reset, which may start the motor. <ul style="list-style-type: none"> • To control automatic reset, use parameter group 31 AUTOMATIC RESET.
2014 (note 1)	AUTOCHANGE	This alarm warns that the PFC autochange function is active. <ul style="list-style-type: none"> • To control PFC, use parameter group 81 PFC CONTROL and "Application Macro: PFC" on page 49.
2015	PFC I LOCK	This alarm warns that the PFC interlocks are active, which means that the drive cannot start the following: <ul style="list-style-type: none"> • Any motor (when Autochange is used), • The speed regulated motor (when Autochange is not used).
2016/ 2017	RESERVED	
2018 (note 1)	PID SLEEP	This alarm warns that the PID sleep function is active, which means that the motor could accelerate when the PID sleep function ends. <ul style="list-style-type: none"> • To control PID sleep, use parameters 4022...4026 or 4122...4126.
2019	RESERVED	
2020	RESERVED	
2021	START ENABLE 1 MISSING	This alarm warns that the Start Enable 1 signal is missing. <ul style="list-style-type: none"> • To control Start Enable 1 function, use parameter 1608. To correct, check: <ul style="list-style-type: none"> • Digital input configuration. • Communication settings.
2022	START ENABLE 2 MISSING	This alarm warns that the Start Enable 2 signal is missing. <ul style="list-style-type: none"> • To control Start Enable 2 function, use parameter 1609. To correct, check: <ul style="list-style-type: none"> • Digital input configuration. • Communication settings.

Alarm Code	Display	Description
2023	EMERGENCY STOP	Emergency stop activated.
2024	If this alarm code appears, refer to the appropriate accessory manual.	
2025	FIRST START	This alarm occurs a few seconds during the scalar flystart first active.
2027	USER LOAD CURVE	This alarm warns that the condition defined by parameter 3701 USER LOAD C MODE has been valid longer than half of the time defined by 3703 USER LOAD C TIME.
2028	START DELAY	Shown during the Start delay. See parameter 2113 START DELAY.

Note 1. Even when the relay output is configured to indicate alarm conditions (e.g. parameter 1401 RELAY OUTPUT 1 = 5 (ALARM) or 16 (FLT/ALARM)), this alarm is not indicated by a relay output.

Alarm Codes (Basic Control Panel)

The Basic Control Panel indicates Control Panel alarms with a code, A5xxx. The following table lists the alarm codes and descriptions.

Code	Description
5001	Drive is not responding.
5002	The communication profile is incompatible with the drive.
5010	The panel's parameter backup file is corrupted.
5011	Drive is controlled from another source.
5012	Rotation direction is locked.
5013	Button is disabled, because start is inhibited.
5014	Button is disabled, because drive is faulted.
5015	Button is disabled, because local mode lock is on.
5018	Parameter default value can't be found.
5019	Writing a non-zero value is prohibited (can only write a zero value).
5020	Group or parameter does not exist or parameter value is inconsistent.
5021	Group or parameter is hidden.
5022	Group or parameter is write protected.
5023	Modification is not allowed while the drive is running.
5024	Drive is busy, try again.
5025	Write is not allowed while upload or download is in progress.
5026	Value is at or below low limit.
5027	Value is at or above high limit.
5028	Value is invalid – doesn't match any values in the discrete values list.
5029	Memory is not ready, try again.
5030	Request is invalid.
5031	Drive is not ready, e.g due to Low DC voltage.
5032	Parameter error was detected.
5040	Selected parameter set can't be found in the current parameter backup.
5041	Parameter backup doesn't fit into memory.

Code	Description
5042	Selected parameter set can't be found in the current parameter backup.
5043	No start inhibit was granted.
5044	Parameter backup versions do not match.
5050	Parameter upload was aborted.
5051	File error was detected.
5052	Parameter upload attempt has failed.
5060	Parameter download was aborted.
5062	Parameter download attempt has failed.
5070	Panel backup memory write error was detected.
5071	Panel backup memory read error was detected.
5080	Operation is not allowed, because the drive is not in local mode.
5081	Operation is not allowed, because a fault is active.
5082	Operation is not allowed, because override mode is enabled.
5083	Operation is not allowed, because parameter lock is not open.
5084	Operation is not allowed, because drive is busy, try again.
5085	Download is not allowed, because drive types are incompatible.
5086	Download is not allowed, because drive models are incompatible.
5087	Download is not allowed, because parameter sets do not match.
5088	Operation failed, because a drive memory error was detected.
5089	Download failed, because a CRC error was detected.
5090	Download failed, because a data processing error was detected.
5091	Operation failed, because a parameter error was detected.
5092	Download failed, because parameter sets do not match.

Maintenance



Warning! Read "Safety" on page 3 before performing any maintenance on the equipment. Ignoring the safety instructions can cause injury or death.

Maintenance Intervals

If installed in an appropriate environment, the drive requires very little maintenance. This table lists the routine maintenance intervals recommended by ABB.

Maintenance	Interval	Instruction
Heatsink temperature check and cleaning	Depends on the dustiness of the environment (every 6...12 months)	See "Heatsink" on page 207.
Main cooling fan replacement	Every six years	See "Main Fan Replacement" on page 208.
Internal enclosure cooling fan replacement (IP54/UL Type 12 drives)	Every three years.	See "Internal Enclosure Fan Replacement" on 209.
Capacitor reforming	Every year when stored	See "Capacitors" on page 209.
Capacitor replacement (Frame sizes R5 and R6)	Every nine to ten years	See "Capacitors" on page 209.

Heatsink

The heatsink fins accumulate dust from the cooling air. Since a dusty heatsink is less efficient at cooling the drive, overtemperature faults become more likely. In a "normal" environment (not dusty, not clean) check the heatsink annually, in a dusty environment check more often.

Clean the heatsink as follows (when necessary):

1. Remove power from drive.
2. Remove the cooling fan (see section "Main Fan Replacement" on page 208).
3. Blow clean compressed air (not humid) from bottom to top and simultaneously use a vacuum cleaner at the air outlet to trap the dust.

Note: If there is a risk of the dust entering adjoining equipment, perform the cleaning in another room.

4. Reinstall the cooling fan.
5. Restore power.

Main Fan Replacement

The drive's main cooling fan has a life span of about 60,000 operating hours at maximum rated operating temperature and drive load. The expected life span doubles for each 10 °C (18 °F) drop in the fan temperature (fan temperature is a function of ambient temperatures and drive loads).

Fan failure can be predicted by the increasing noise from fan bearings and the gradual rise in the heatsink temperature in spite of heatsink cleaning. If the drive is operated in a critical part of a process, fan replacement is recommended once these symptoms start appearing. Replacement fans are available from ABB. Do not use other than ABB specified spare parts.

Frame Sizes R1...R4

To replace the fan:

1. Remove power from drive.
2. Remove drive cover.
3. For Frame Size:
 - R1, R2: Press together the retaining clips on the fan cover sides, and lift.
 - R3, R4: Press in on the lever located on the left side of the fan mount, and rotate the fan up and out.
4. Disconnect the fan cable.
5. Install the fan in reverse order.
6. Restore power.

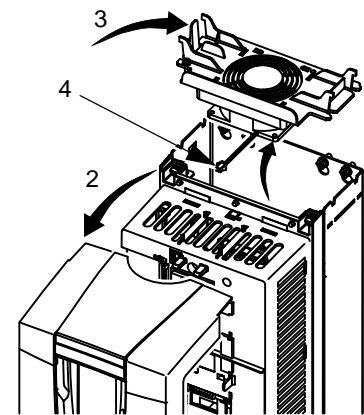

X0021

Frame Sizes R5 and R6

To replace the fan:

1. Remove power from drive.
2. Remove the screws attaching the fan.
3. Remove the fan:
 - R5: Swing the fan out on its hinges.
 - R6: Pull the fan out.
4. Disconnect the fan cable.
5. Install the fan in reverse order.
6. Restore power.

Bottom View (R5)

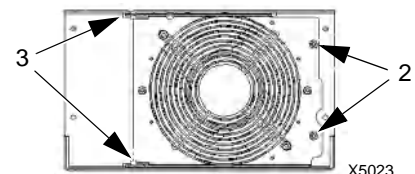

X5023

Bottom View (R6)

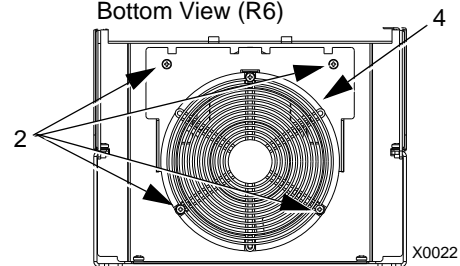

X0022

Internal Enclosure Fan Replacement

IP54 enclosures have an additional internal fan to circulate air inside the enclosure.

Frame Sizes R1...R4

To replace the internal enclosure fan in frame sizes R1 to R3 (located at the top of the drive) and R4 (located in front of the drive):

1. Remove power from drive.
2. Remove the front cover.
3. The housing that holds the fan in place has barbed retaining clips at each corner. Press all four clips toward the center to release the barbs.
4. When the clips/barbs are free, pull the housing up to remove from the drive.
5. Disconnect the fan cable.
6. Install the fan in reverse order, noting that:
 - The fan air flow is up (refer to arrow on fan).
 - The fan wire harness is toward the front.
 - The notched housing barb is located in the right-rear corner.
 - The fan cable connects just forward of the fan at the top of the drive.

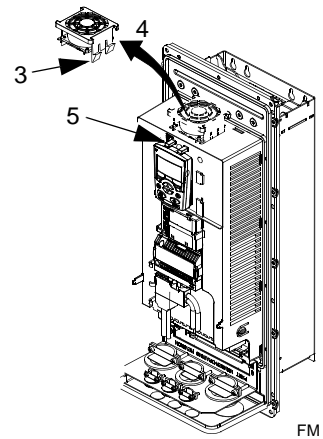

Frame Sizes R5 and R6

To replace the internal enclosure fan in frame sizes R5 or R6:

- Remove power from drive.
- Remove the front cover.
- Lift the fan out and disconnect the cable.
- Install the fan in reverse order.
- Restore power.

Capacitors

Reforming

The drive DC link capacitors need to be reformed (re-aged) if the drive has been non-operational for more than one year. Without reforming, capacitors may be damaged when the drive starts to operate. It is therefore recommended to reform the capacitors once a year.

For information on reforming the capacitors, refer to *Guide for Capacitor Reforming in ACS50/150/350/550* [3AFE68735190 (English)], available on the Internet (go to www.abb.com and enter the code in the Search field).

Replacement

The drive intermediate circuit employs several electrolytic capacitors. Their life span is from 35,000...90,000 hours depending on drive loading and ambient temperature. Capacitor life can be prolonged by lowering the ambient temperature.

It is not possible to predict a capacitor failure. Capacitor failure is usually followed by a input power fuse failure or a fault trip. Contact ABB if capacitor failure is suspected. Replacements for frame size R5 and R6 are available from ABB. Do not use other than ABB specified spare parts.

Control Panel

Cleaning

Use a soft damp cloth to clean the control panel. Avoid harsh cleaners which could scratch the display window.

Technical Data

Ratings

By type code, the table below provides ratings for the ACS510 adjustable speed AC drive, including:

- IEC ratings
- NEMA ratings (shaded columns)
- Frame size

Ratings, 380...480 Volt Drives

Abbreviated column headers are described in "Symbols" on page 212.

Type Code	Pump and Fan Use			Frame Size
	I_{2N} A	P_N kW	P_N hP	
ACS510-01- see below				
Three-phase supply voltage, 380...480 V				
-03A3-4	3.3	1.1	1.5	R1
-04A1-4	4.1	1.5	2	R1
-05A6-4	5.6	2.2	3	R1
-07A2-4	7.2	3	4	R1
-09A4-4	9.4	4	5.4	R1
-012A-4	11.9	5.5	7.5	R1
-017A-4	17	7.5	10	R2
-025A-4	25	11	15	R2
-031A-4	31	15	20	R3
-038A-4	38	18.5	25	R3
-046A-4	46	22	30	R3
-060A-4	60	30	40	R4
-072A-4	72	37	50	R4
-088A-4	88	45	60	R4
-125A-4	125	55	100	R5
-157A-4	157	75	125	R6
-180A-4	180	90	150	R6
-195A-4	205	110	150	R6
-246A-4	245	132	200	R6
-290A-4	290	160	200	R6

Symbols

Typical ratings:

Pump and Fan use

I_{2N}	continuous rms current.
P_N	typical motor power in normal use. The kilowatt power ratings apply to most IEC, 4-pole motors. The Horsepower ratings apply to most 4-pole NEMA motors.

Sizing

The current ratings are the same regardless of the supply voltage within one voltage range. To achieve the rated motor power given in the table, the rated current of the drive must be higher than or equal to the rated motor current. Also note that:

- The ratings apply for ambient temperature of 40 °C (104 °F).

Derating

The load capacity (current and power) decreases for certain situations, as defined below. In such situations, where full motor power is required, oversize the drive so that the derated value provides sufficient capacity.

For example, if your application requires 15.4 A of motor current and a 8 kHz switching frequency, calculate the appropriate drive size requirement as follows:

The minimum size required = $15.4 \text{ A} / 0.80 = 19.25 \text{ A}$

Where: 0.80 is the derating for 8 kHz switching frequency (see "Switching Frequency Derating" below).

Referring to I_{2N} in the ratings tables (page 211), the following drives exceed the I_{2N} requirement of 19.25 A: ACS510-01-025A-4.

Temperature Derating

In the temperature range +40 °C...50 °C (+104 °F...122 °F) the rated output current is decreased 1% for every 1 °C (1.8 °F) above +40 °C (+104 °F). The output current is calculated by multiplying the current given in the rating table by the derating factor.

Example If the ambient temperature is 50 °C (+122 °F) the derating factor is $100\% - 1\%/^{\circ}\text{C} \times 10 \text{ }^{\circ}\text{C} = 90\%$ or 0.90.

The output current is then $0.90 \times I_{2N}$.

Altitude Derating

In altitudes 1000...4000 m (3300...13,200 ft) above sea level, the derating is 1% for every 100 m (330 ft). If the installation site is higher than 2000 m (6600 ft) above sea level, please contact your local ABB distributor or office for further information.

Switching Frequency Derating

If the 8 kHz switching frequency (parameter 2606) is used, either:

- Derate P_N and I_{2N} to 80% or
- Set parameter 2607 SW FREQ CTRL = 1 (ON) which allows the drive to reduce the switching frequency if/when the drive's internal temperature exceeds 90 °C. See the parameter description for 2607 for details.

If the 12 kHz switching frequency (parameter 2606) is used, either:

- Derate P_N and I_{2N} to 65%, and derate ambient temperature maximum to 30 °C (86 °F), or
- Set parameter 2607 SW FREQ CTRL = 1 (ON) which allows the drive to reduce the switching frequency if/when the drive's internal temperature exceeds 80 °C. See the parameter description for 2607 for details.

Input Power Connections



Warning! Do not operate the drive outside the nominal input line voltage range. Over-voltage can result in permanent damage to the drive.

Input Power Specifications

Input Power (Mains) Connection Specifications	
Voltage (U_1)	380/400/415/440/460/480 V AC 3-phase -15%...+10%
Prospective short-circuit current (IEC 629)	Maximum allowed prospective short-circuit current in the supply is 100 kA providing that the input power cable of the drive is protected with appropriate fuses. US: 100 000 AIC.
Frequency	48...63 Hz
Imbalance	Max. \pm 3% of nominal phase to phase input voltage
Fundamental power factor ($\cos \phi_1$)	0.98 (at nominal load)
Cable Temperature Rating	90 °C (194 °F) rating minimum.

Disconnect Device

The ACS510 does not include a disconnect device. A means to disconnect input power must be installed between the AC power source and the ACS510. This disconnect device must:

- Be sized to conform to applicable safety regulations, including, but not limited to, both national and local electrical codes.
- Be locked in the open position during installation and maintenance work.

The disconnect device must not be used to control the motor. Instead use the control panel, or commands to the I/O terminals for motor control.

Fuses

Branch circuit protection must be provided by the end-user, and sized per national and local electric codes. The following tables provide fuse recommendations for short circuit protection on the drive's input power.

Fuses, 380...480 V Drives

ACS510-01- see below	Input Current A	Input power (mains) fuses		
		IEC 269 gG (A)	UL Class T (A)	Bussmann Type
-03A3-4	3.3	10	10	JJS-10
-04A1-4	4.1			
-05A6-4	5.6			
-07A2-4	7.2			
-09A4-4	9.4			
-012A-4	11.9	16	15	JJS-15
-017A-4	17		20	JJS-20
-025A-4	25	25	30	JJS-30
-031A-4	31	35	40	JJS-40
-038A-4	38	50	50	JJS-50
-046A-4	46		60	JJS-60
-060A-4	60	63	80	JJS-80
-072A-4	72	80	90	JJS-90
-088A-4	88	125	125	JJS-125
-125A-4	125	160	175	JJS-175
-157A-4	157	200	200	JJS-200
-180A-4	180	250	250	JJS-250
-195A-4	205	250	250	JJS-250
-246A-4	245	250	250	JJS-250
-290A-4	290	315	315	JJS-350

Emergency Stop Devices

The overall design of the installation must include emergency stop devices and any other safety equipment that may be needed. Pressing STOP on the drive's control panel does NOT:

- Generate an emergency stop of the motor.
- Separate the drive from dangerous potential.

Input Power Cables/ Wiring

Input wiring can be any of:

- A four conductor cable (three phases and ground/protective earth). Shielding is not required.
- Four insulated conductors routed through conduit.

Size wiring according to local safety regulations, appropriate input voltage and the drive's load current. In any case, the conductor must be less than the maximum limit defined by the terminal size (see "Drive's Power Connection Terminals" on page 218).

The table below lists copper and aluminum cable types for different load currents. These recommendations apply only for the conditions listed at the top of the table.

IEC				NEC	
Based on: <ul style="list-style-type: none"> • EN 60204-1 and IEC 60364-5-2/2001 • PVC insulation • 30 °C (86 °F) ambient temperature • 70 °C (158 °F) surface temperature • Cables with concentric copper shield • Not more than nine cables laid on cable ladder side by side. 				Based on: <ul style="list-style-type: none"> • NEC Table 310-16 for copper wires • 90 °C (194 °F) wire insulation • 40 °C (104 °F) ambient temperature • Not more than three current-carrying conductors in raceway or cable, or earth (directly buried). • Copper cables with concentric copper shield 	
Max Load Current (A)	Cu Cable (mm ²)	Max Load Current (A)	Al Cable (mm ²)	Max Load Current (A)	Cu Wire Size (AWG/kcmil)
14	3x1.5	Do not use aluminum cable with frame sizes R1...R4		22.8	14
20	3x2.5			27.3	12
27	3x4			36.4	10
34	3x6			50.1	8
47	3x10			68.3	6
62	3x16			86.5	4
79	3x25			100	3
98	3x35			91	3x50
119	3x50	117	3x70	137	1
153	3x70	143	3x95	155	1/0
186	3x95	165	3x120	178	2/0
215	3x120	191	3x150	205	3/0
249	3x150	218	3x185	237	4/0
284	3x185	257	3x240	264	250 MCM or 2 x 1
		274	3x (3x50)	291	300 MCM or 2 x 1/0
		285	2x (3x95)	319	350 MCM or 2 x 2/0

Ground Connections

For personnel safety, proper operation and reduction of electromagnetic emission/pick-up, the drive and the motor must be grounded at the installation site.

- Conductors must be adequately sized as required by safety regulations.
- Power cable shields must be connected to the drive PE terminal in order to meet safety regulations.
- Power cable shields are suitable for use as equipment grounding conductors only when the shield conductors are adequately sized as required by safety regulations.
- In multiple drive installations, do not connect drive terminals in series.

Unsymmetrically Grounded Networks



Warning! Do not attempt to install or remove EM1 or EM3 screws while power is applied to the drive's input terminals.

Unsymmetrically grounded networks are defined in the following table. In such systems, disconnect the internal ground connection by removing the screws (do this also if the grounding configuration of the system is unknown):

- ACS510-01, frame sizes R1...R4: Remove both the EM1 and EM3 screws.
- Frame sizes R5...R6: Remove both the F1 and F2 screws.

Unsymmetrically Grounded systems – EM1, EM3, F1 and F2 must be out			
Grounded at the corner of the delta		Grounded at the mid point of a delta leg	
Single phase, grounded at an end point		Three phase "Variac" without solidly grounded neutral	

The screws (M4x16) make an internal ground connection that reduces electro-magnetic emission. Where EMC (electro-magnetic compatibility) is a concern, and the system is symmetrically grounded, the screws may be installed. For reference, the diagram on the right illustrates a symmetrically grounded TN system.

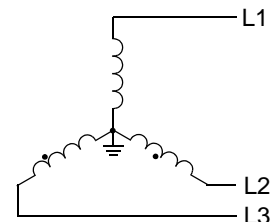

Floating Networks



Warning! Do not attempt to install or remove EM1, EM3, F1 or F2 screws while power is applied to the drive's input terminals.

For floating networks (also known as IT, ungrounded, or impedance/resistance grounded networks):

- Disconnect the ground connection to the internal RFI filters:
 - ACS510-01, frame sizes R1...R4: Remove both the EM1 and EM3 screws (see "Power Connection Diagrams" on page 15).
 - Frame sizes R5...R6: Remove both the F1 and F2 screws (see page 16).
- Where EMC requirements exist, check for excessive emission propagated to neighboring low voltage networks. In some cases, the natural suppression in

transformers and cables is sufficient. If in doubt, use a supply transformer with static screening between the primary and secondary windings.

- Do NOT install an external RFI/EMC filter. Using an RFI filter grounds the input power through the filter capacitors, which could be dangerous and could damage the drive.

Drive's Power Connection Terminals

The following table provides specifications for the drive's power connection terminals.

Frame size	U1, V1, W1 U2, V2, W2 BRK \pm , UDC \pm terminals				Earthing PE terminal			
	Max. terminal size		Torque		Max. terminal size		Torque	
	mm ²	AWG	N-m	lb-ft	mm ²	AWG	N-m	lb-ft
R1 ¹	6	8	1.4	1	4	10	1.4	1
R2 ¹	10	6	1.4	1	10	8	1.4	1
R3 ¹	25	3	1.8	1.3	16	6	1.8	1.3
R4 ¹	50	1/0	2	1.5	35	2	2	2
R5 ¹	70	2/0	15	11	70	2/0	15	11
R6	185	350 MCM	40	30	95	4/0	8	6

1. Do not use aluminum cable with frame sizes R1...R5.

Power Terminal Considerations – R6 Frame Size



Warning! For R6 power terminals, if compression lugs are supplied, they can only be used for wire sizes that are 95 mm² (3/0 AWG) or larger. Smaller wires will loosen and may damage the drive, and require ring lugs as described below.

Ring Lugs

On the R6 frame size, if the cable size used is less than 95 mm² (3/0 AWG) or if no compression lugs are supplied, use ring lugs according to the following procedure.

1. Select appropriate ring lugs from the following table.
2. Attach the supplied terminal lugs to the drive end of the cables.
3. Isolate the ends of the ring lugs with insulating tape or shrink tubing.

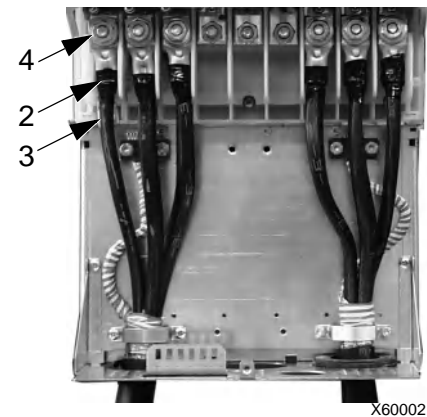

X60002

4. Attach terminal lug to the drive.

Wire Size		Manufacturer	Ring Lug	Crimping Tool	No. of Crimps
mm ²	kcmil/ AWG				
16	6	Burndy	YAV6C-L2	MY29-3	1
		IlSCO	CCL-6-38	ILC-10	2
25	4	Burndy	YA4C-L4BOX	MY29-3	1
		IlSCO	CCL-4-38	MT-25	1
35	2	Burndy	YA2C-L4BOX	MY29-3	2
		IlSCO	CRC-2	IDT-12	1
		IlSCO	CCL-2-38	MT-25	1
50	1	Burndy	YA1C-L4BOX	MY29-3	2
		IlSCO	CRA-1-38	IDT-12	1
		IlSCO	CCL-1-38	MT-25	1
		Thomas & Betts	54148	TBM-8	3
55	1/0	Burndy	YA25-L4BOX	MY29-3	2
		IlSCO	CRB-0	IDT-12	1
		IlSCO	CCL-1/0-38	MT-25	1
		Thomas & Betts	54109	TBM-8	3
70	2/0	Burndy	YAL26T38	MY29-3	2
		IlSCO	CRA-2/0	IDT-12	1
		IlSCO	CCL-2/0-38	MT-25	1
		Thomas & Betts	54110	TBM-8	3
95	3/0	Burndy	YAL27T38	MY29-3	2
		IlSCO	CRA-3/0	IDT-12	1
		IlSCO	CCL-3/0-38	MT-25	1
		Thomas & Betts	54111	TBM-8	3
95	3/0	Burndy	YA28R4	MY29-3	2
		IlSCO	CRA-4/0	IDT-12	1
		IlSCO	CCL-4/0-38	MT-25	2
		Thomas & Betts	54112	TBM-8	4

Compression Lugs

Use the following procedure to attach cables if compression lugs are supplied and can be used.

1. Attach the supplied compression lugs to the drive end of the cables.
2. Attach compression lug to the drive.

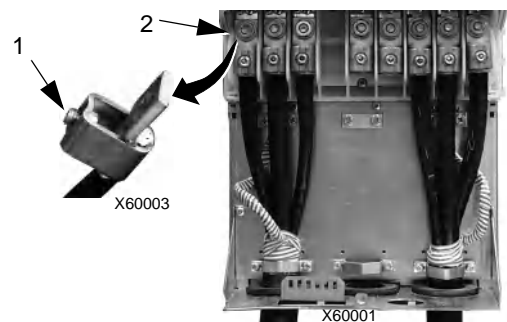

Motor Connections



Warning! Never connect line power to the drive output terminals: U2, V2 or W2. Line voltage applied to the output can result in permanent damage to the unit. If frequent bypassing is required, use mechanically interlocked switches or contactors.



Warning! Do not connect any motor with a nominal voltage less than one half of the drive's nominal input voltage.



Warning! Disconnect the drive before conducting any voltage tolerance (Hi-Pot) test or insulation resistance (Megger) test on the motor or motor cables. Do not conduct these tests on the drive.

Motor connection specifications

Motor connection specifications							
Voltage (U_2)	0... U_1 , 3-phase symmetrical, U_{max} at the field weakening point						
Frequency	0...500 Hz						
Frequency resolution	0.01 Hz						
Current	See "Ratings" on page 211.						
Field weakening point	10...500 Hz						
Switching frequency	Selectable. See the availability in the table below.						
		<table border="1"> <thead> <tr> <th></th> <th>1, 4 and 8 kHz</th> <th>12 kHz</th> </tr> </thead> <tbody> <tr> <td>380...480 V</td> <td>All types, except for ACS510-01-246A-4 and ACS510-01-290A-4 (only 1 and 4 kHz)</td> <td>Frame sizes R1...R4, except for ACS510-01-088A-4</td> </tr> </tbody> </table>		1, 4 and 8 kHz	12 kHz	380...480 V	All types, except for ACS510-01-246A-4 and ACS510-01-290A-4 (only 1 and 4 kHz)
	1, 4 and 8 kHz	12 kHz					
380...480 V	All types, except for ACS510-01-246A-4 and ACS510-01-290A-4 (only 1 and 4 kHz)	Frame sizes R1...R4, except for ACS510-01-088A-4					
Cable temperature rating	90 °C (194 °F) rating minimum.						
Maximum motor cable length	See sections <Cross-reference>Motor cable length for 400 V drives .						

Motor cable length for 400 V drives

The table below shows the maximum motor cable lengths for 400 V drives with different switching frequencies. Examples for using the table are also given.

Maximum cable length for 400 V drives																				
Frame size	EMC limits												Operational limits							
	Second environment (category C3 ¹)						First environment (category C2 ¹)						Basic unit				With du/dt filters			
	1 kHz		4 kHz		8 kHz		1 kHz		4 kHz		8 kHz		1/4 kHz		8/12 kHz		m		ft	
	m	ft	m	ft	m	ft	m	ft	m	ft	m	ft	m	ft	m	ft	m	ft	m	ft
R1	300	980	300	980	300	980	300	980	300	980	300	980	100	330	100	330	150	490		
R2	300	980	300	980	300	980	300	980	100	330	30	98	200	660	100	330	250	820		
R3	300	980	300	980	300	980	300	980	75	245	75	245	200	660	100	330	250	820		
R4	300	980	300	980	300	980	300	980	75	245	75	245	200	660	100	330	300	980		
R5	100	330	100	330	100	330	100	330	100	330	100	330	300	980	150 ²	490 ²	300	980		
R6	100	330	100	330	³	³	100	330	100	330	³	³	300	980	150 ²	490 ²	300	980		

¹ See the new terms in section [IEC/EN 61800-3 \(2004\) Definitions](#).

² 12 kHz switching frequency is not available.

³ Not tested.

Sine filters further extend the cable lengths.



WARNING! Using a motor cable longer than specified in the table above may cause permanent damage to the drive.

Examples for using the table:

Requirements	Checking and conclusions
R1 frame size, 8 kHz fsw, Category C2, 150 m (490 ft) cable	Check operational limits for R1 and 8 kHz -> for a 150 m (490 ft) cable a du/dt filter is needed. Check EMC limits -> EMC requirements for Category C2 are met with a 150 m (490 ft) cable.
R3 frame size, 4 kHz fsw, Category C3, 300 m (980 ft) cable	Check operational limits for R3 and 4 kHz -> a 300 m (980 ft) cable cannot be used even with a du/dt filter. A sine filter must be used and the voltage drop of the cable must be taken into account in the installation. Check EMC limits -> EMC requirements for Category C3 are met with a 300 m (980 ft) cable.
R5 frame size, 8 kHz fsw, Category C3, 150 m (490 ft) cable	Check operational limits for R5 and 8 kHz -> for a 150 m (490 ft) cable the basic unit is sufficient. Check EMC limits -> EMC requirements for Category C3 cannot be met with a 300 m (980 ft) cable. The installation configuration is not possible. An EMC plan is recommended to overcome the situation.
R6 frame size, 4 kHz fsw, EMC limits not applicable, 150 m (490 ft) cable	Check operational limits for R6 and 4 kHz -> for a 150 m (490 ft) cable the basic unit is sufficient. EMC limits do not need to be checked as there are no EMC requirements.

Motor thermal protection

According to regulations, the motor must be protected against thermal overload and the current must be switched off when overload is detected. The drive includes a motor thermal protection function that protects the motor and switches off the current when necessary. Depending on a drive parameter value (see <Cross-reference>Group 35: MOTOR TEMP MEAS), the function either monitors a calculated temperature value (based on a motor thermal model) or an actual temperature indication given by motor temperature sensors. The user can tune the thermal model further by feeding in additional motor and load data.

The most common temperature sensors are:

- motor sizes IEC180...225: thermal switch (e.g. Klixon)
- motor sizes IEC200...250 and larger: PTC or PT100.

Ground Fault Protection

ACS510 internal fault logic detects ground faults in the drive, motor, or motor cable. This fault logic:

- Is NOT a personal safety or fire protection feature.
- Can be disabled using parameter 3017 EARTH FAULT.
- Could be tripped by leakage currents (input power to ground) associated with long high capacitance motor cables.

Grounding and Routing

Motor Cable Shielding

Motor cables require shielding using conduit, armored cable or shielded cable.

- Conduit – When using conduit:
 - Bridge joints with a ground conductor bonded to the conduit on each side of the joint.
 - Bond conduit run to the drive enclosure.
 - Use a separate conduit run for motor cables (also separate input power and control cables).
 - Use a separate conduit run for each drive.
- Armored Cable – When using armored cable:
 - Use six-conductor (3 phases and 3 grounds), type MC continuous corrugated aluminum armor cable with symmetrical grounds.
 - Armored motor cable can share a cable tray with input power cables, but not with control cables.
- Shielded Cable – For shielded cable details, see "Motor Cable Requirements for CE Compliance" below.

Grounding

See "Ground Connections" in "Input Power Connections" above.

For CE compliant installations and installations where EMC emissions must be minimized, see "Effective Motor Cable Screens" below.

Drive's Motor Connection Terminals

The drive's motor and input power terminals have the same specifications. See "Drive's Power Connection Terminals" above.

Motor Cable Requirements for CE Compliance

The requirements in this section apply for CE compliance.

Minimum Requirement (CE)

The motor cable must be a symmetrical three conductor cable with a concentric PE conductor or a four conductor cable with a concentric shield, however, a symmetrical constructed PE conductor is always recommended. The following figure shows the minimum requirement for the motor cable screen (for example, MCMK, NK Cables).

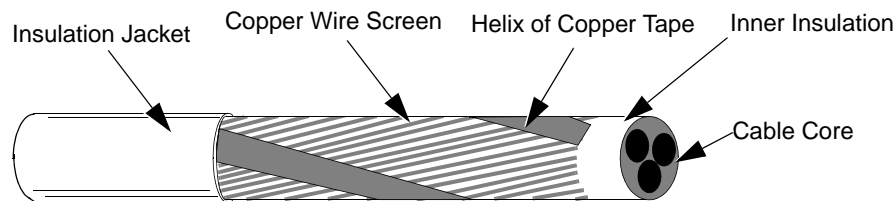

Recommendation for Conductor Layout

The following figure compares conductor layout features in motor cables.

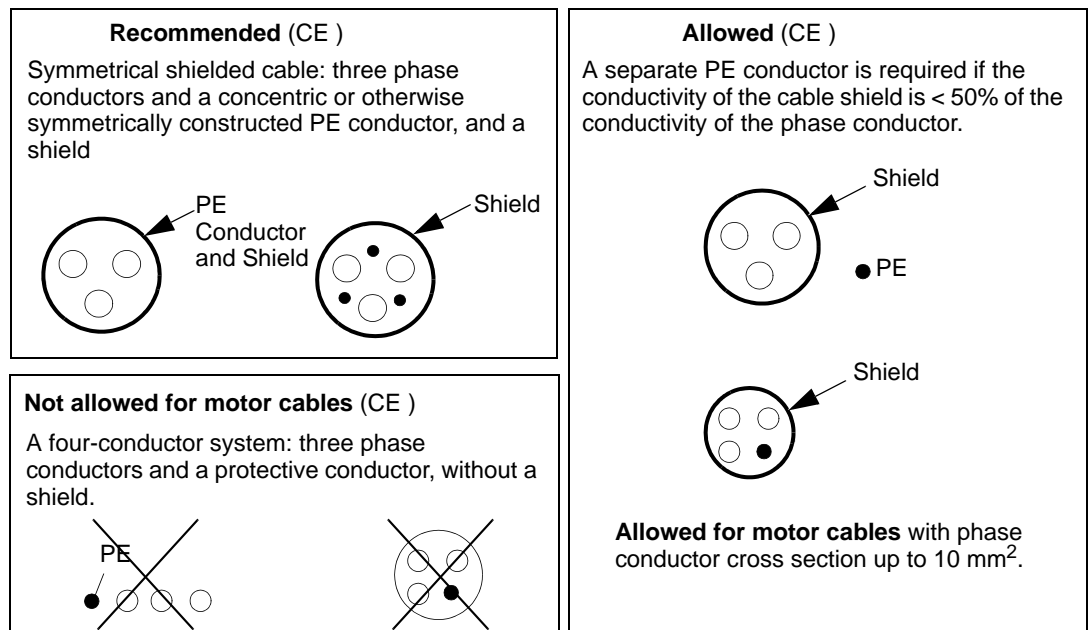

Effective Motor Cable Screens

The general rule for cable screen effectiveness is: the better and tighter the cable's screen, the lower the radiated emission level. The following figure shows an

example of an effective construction (for example Ölflex-Servo-FD 780 CP, Lappkabel or MCCMK, NK Cables).

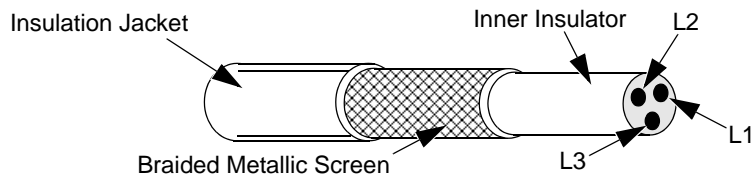

EN 61800-3 Compliant Motor Cables

To comply with EN 61800-3 requirements:

- Motor cables must have an effective screen as described in "Effective Motor Cable Screens" on page 223.
- Motor cable screen wires must be twisted together into a bundle (the bundle length must be less than five times its width) and connected it to the terminal marked \perp (at the bottom right-hand corner of the drive).
- Motor cables must be grounded, at the motor end, with an EMC cable gland. The ground must contact the cable screen all the way around the cable.
- For EN 61800-3 First Environment, Restricted Distribution (CISPR11 Class A), and EN 61800-3 Second Environment compliance, the drive includes an internal filter that provides compliance for at least 30 m (100 ft.) motor cable lengths. For some drives, longer cable lengths require an additional, external RFI/EMC filter as specified in the table below. The RFI/EMC filters are separate options and installation must conform to the instructions in the filter package for all cable screen connections.

Brake Components

Availability

Braking availability for ACS510 drives, by frame size is:

- R1 and R2 – a built-in brake chopper is standard equipment. Add appropriate resistor, as determined using the following section. Resistors are available from ABB.
- R3...R6 – does not include an internal brake chopper. Connect a chopper and a resistor, or a brake unit to the DC link terminals on the drive. Contact your ABB representative for appropriate parts.

Selecting the Braking Resistors (Frame Sizes R1 and R2)

Braking resistor must meet three requirements:

- Resistance must be always higher than the minimum value R_{MIN} defined for the drive type in the following tables. Never use resistance below this value.
- Resistance must be low enough to be able to produce the desired braking torque. To achieve the maximum braking torque (the larger of 150% of heavy duty or 110% of nominal duty), the resistance must not exceed R_{MAX} . If maximum braking torque is not necessary, resistor values can exceed R_{MAX} .
- The resistor power rating must be high enough to dissipate the braking power. This requirement involves many factors:
 - The maximum continuous power rating for the resistor(s).
 - The rate at which the resistor changes temperature (resistor thermal time constant).
 - Maximum braking time ON – If the regeneration (braking) power is larger than the resistor rated power, there is a limit to the ON time, or the resistor overheats before the OFF period begins.
 - Minimum braking time OFF – If the regeneration (braking) power is larger than the resistor rated power, the OFF time must be large enough for the resistor to cool between ON periods.

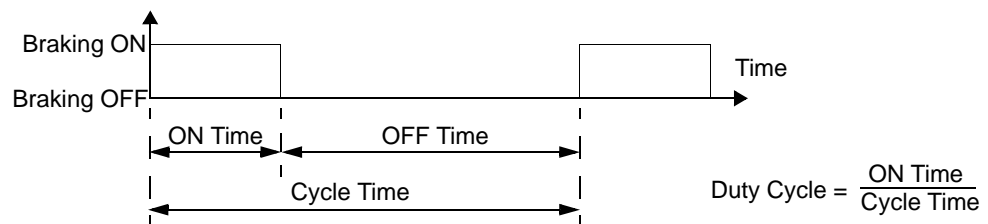

- The peak braking power requirement.
- Type of braking (deceleration to zero vs. overhauling load) – During deceleration to zero, the generated power steadily decreases, averaging half of the peak power. For an overhauling load, the braking is countering an external force (gravity for example) and the braking power is constant. The total heat generated from an overhauling load is double the heat generated from deceleration to zero speed (for the same peak torque and ON time).

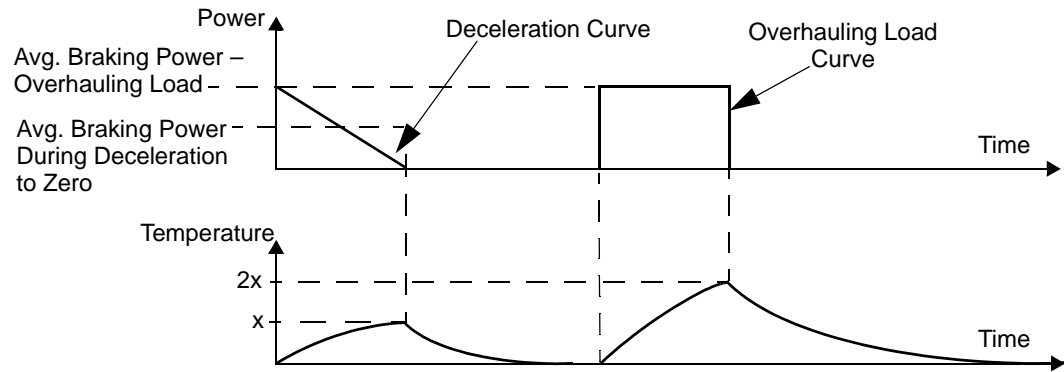

The many variables in the last requirement above are most easily dealt with using the following tables.

- First, determine your maximum braking time ON (ON_{MAX}), minimum braking time OFF (OFF_{MIN}) and load type (deceleration or overhauling load).
- Calculate duty cycle:

$$\text{Duty Cycle} = \frac{ON_{MAX}}{(ON_{MAX} + OFF_{MIN})} \cdot 100\%$$

- In the appropriate table, find the column that best matches your data:
 - $ON_{MAX} \leq$ column specification and
 - Duty Cycle \leq column specification
- Find the row that matches your drive.
- The minimum power rating for deceleration to zero is the value in the selected row/column.
- For overhauling loads, double the rating in the selected row/column, or use the Continuous ON column.

380...480 V Drives

Type Code ACS510- 01- see below	Resistance		Resistor ¹ Minimum Continuous Power Rating				
	R _{MAX}	R _{MIN}	Deceleration-to-Zero Rating				P _{rcont} Continuous ON > 60 s ON > 25% Duty
			P _{r3} ≤ 3 s ON ≥ 27 s OFF ≤ 10% Duty	P _{r10} ≤ 10 s ON ≥ 50 s OFF ≤ 17% Duty	P _{r30} ≤ 30 s ON ≥ 180 s OFF ≤ 14% Duty	P _{r60} ≤ 60 s ON ≥ 180 s OFF ≤ 25% Duty	
ohm	ohm	W	W	W	W	W	
Three-phase supply voltage, 380...480 V							
-03A3-4	641	120	65	120	175	285	1100
-04A1-4	470	120	90	160	235	390	1500
-05A6-4	320	120	125	235	345	570	2200
-07A2-4	235	80	170	320	470	775	3000
-09A4-4	192	80	210	400	575	950	4000
-012A-4	128	80	315	590	860	1425	5500
-017A-4	94	63	425	800	1175	1950	7500
-025A-4	64	63	625	1175	1725	2850	11000

1. Resistor time constant specification must be ≥ 85 seconds.



WARNING! Never use a brake resistor with a resistance below the minimum value specified for the particular drive. The drive and the internal chopper are not able to handle the overcurrent caused by the low resistance.

Symbols

R_{MIN} – Minimum allowed braking resistor.

R_{MAX} – Maximum resistance allowed if maximum braking torque is necessary.

P_{rx} – Duty-cycle based resistor power rating in deceleration braking, where “x” is ON_{MAX} time.

Installing and Wiring Resistors

All resistors must be installed outside the drive module in a place where they can dissipate heat.



Warning! The surface temperature of the resistor is very high and air flowing from the resistor is very hot. Materials near the brake resistor must be non-flammable. Provide protection from accidental contact with the resistor.

To ensure that the input fuses protect the resistor cable, use resistor cables with the same rating as used for the power input to the drive.

The maximum length of the resistor cable(s) is 10 m (33 ft). See the "Power Connection Diagrams" on page 15 for the resistor cable connection points.

Mandatory Circuit Protection

The following setup is essential for safety – it interrupts the main supply in fault situations involving chopper shorts:

- Equip the drive with a main contactor.
- Wire the contactor so that it opens if the resistor thermal switch opens (an overheated resistor opens the contactor).

Below is a simple wiring diagram example.

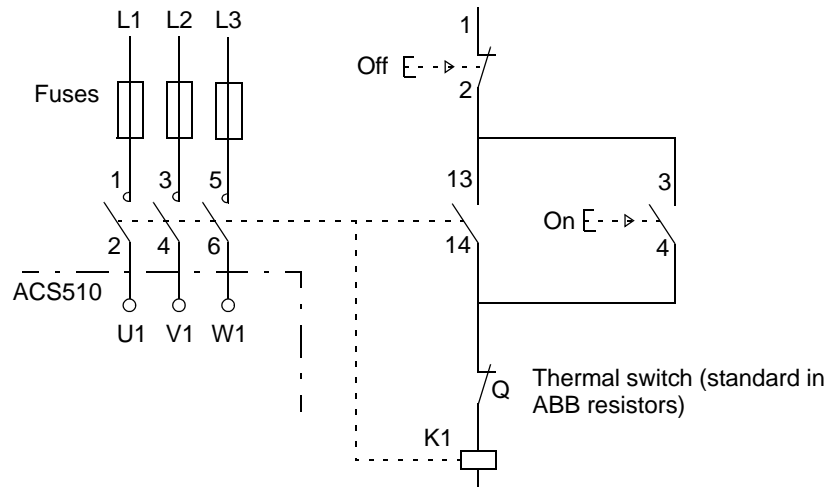

Parameter Set-up

To enable dynamic braking, switch off the drive's overvoltage control (Set parameter 2005 = 0 (DISABLE))

Control Connections

Control Connection Specifications

Control Connection Specifications	
Analog Inputs and Outputs	See table heading "Hardware Description" on page 17.
Digital Inputs	Digital input impedance 1.5 k Ω . Maximum voltage for digital inputs is 30 V.
Relays (Digital Outputs)	<ul style="list-style-type: none"> • Max. contact voltage: 30 V DC, 250 V AC • Max. contact current / power: 6 A, 30 V DC; 1500 VA, 250 V AC • Max. continuous current: 2 A rms ($\cos \varphi = 1$), 1 A rms ($\cos \varphi = 0.4$) • Minimum load: 500 mW (12 V, 10 mA) • Contact material: Silver-nickel (AgN) • Isolation between relay digital outputs, test voltage: 2.5 kV rms, 1 minute
Cable Specifications	See "Control Terminals Table" on page 17.

Control Cables

General Recommendations

Use multi-core cables with a braided copper wire screen, temperature rated at 60 °C (140 °F) or above:

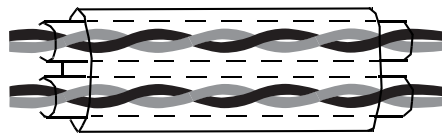

Double Shielded
Example: JAMAK by Draka NK Cables

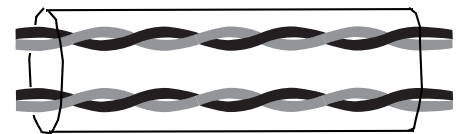

Single Shielded
Example: NOMAK by Draka NK Cables

At the drive end, twist the screen together into a bundle not longer than five times its width and connected to terminal X1-1 (for digital and analog I/O cables) or to either X1-28 or X1-32 (for RS485 cables). Leave the other end of the cable shield unconnected.

Route control cables to minimize radiation to the cable:

- Route as far away as possible from the input power and motor cables (at least 20 cm (8 in)).
- Where control cables must cross power cables make sure they are at an angle as near 90° as possible.
- Stay at least 20 cm (8 in) from the sides of the drive.

Use care in mixing signal types on the same cable:

- Do not mix analog and digital input signals on the same cable.
- Run relay-controlled signals as twisted pairs (especially if voltage > 48 V). Relay-controlled signals using less than 48 V can be run in the same cables as digital input signals.

Note! Never mix 24 V DC and 115/230 V AC signals in the same cable.

Analog Cables

Recommendations for analog signal runs:

- Use double shielded, twisted pair cable.
- Use one individually shielded pair for each signal.
- Do not use a common return for different analog signals.

Digital Cables

Recommendation for digital signal runs: A double shielded cable is the best alternative, but single-shielded, twisted, multi-pair cable is also usable.

Control Panel Cable

If the control panel is connected to the drive with a cable, use only Category 5 Patch ethernet cable. The maximum length that is tested to meet EMC specifications is 3 m (9.8 ft). Longer cables are susceptible to electromagnetic noise and must be user-tested to verify that EMC requirements are met. Where long runs are required (especially for runs longer than about 12 m (40 ft)), use a RS232/RS485 converter at each end and run RS485 cable.

Drive's Control Connection Terminals

The following table provides specifications for the drive's control terminals

Frame Size	Control			
	Maximum Wire Size		Torque	
	mm ²	AWG	Nm	lb-ft
All	1.5	16	0.4	0.3

Efficiency

Approximately 98% at nominal power level.

Cooling

Cooling Specifications	
Method	Internal fan, flow direction from bottom to top.
Requirement	Free space above and below the ACS510 drive: 200 mm (8 in). Free space is not required on the drive's sides – ACS510 drives can be mounted side-by-side.

Air Flow, 380...480 V Drives

The following table lists heat loss and air flow data for 380...480 Volt drives.

Drive		Heat Loss		Air Flow	
ACS510-01-	Frame Size	W	BTU/hr	m ³ /h	ft ³ /min
-03A3-4	R1	40	137	44	26
-04A1-4	R1	52	178	44	26

Drive		Heat Loss		Air Flow	
ACS510-01-	Frame Size	W	BTU/hr	m ³ /h	ft ³ /min
-05A6-4	R1	73	249	44	26
-07A2-4	R1	97	331	44	26
-09A4-4	R1	127	434	44	26
-012A-4	R1	172	587	44	26
-017A-4	R2	232	792	88	52
-025A-4	R2	337	1151	88	52
-031A-4	R3	457	1561	134	79
-038A-4	R3	562	1919	134	79
-046A-4	R3	667	2278	134	79
-060A-4	R4	907	3096	280	165
-072A-4	R4	1120	3825	280	165
-088A-4	R4	1440	4918	280	165
-125A-4	R5	1940	6625	350	205
-157A-4	R6	2310	7889	405	238
-180A-4	R6	2810	9597	405	238
-195A-4	R6	3050	10416	405	238
-246A-4	R6	3850	13148	540	318
-290A-4	R6	4550	15539	540	318

Dimensions and Weights

The dimensions and mass for the ACS510 depend on the frame size and enclosure type. If unsure of frame size, first, find the "Type" code on the drive labels. Then look up that type code in the "Technical Data" on page 211, to determine the frame size. A complete set of dimensional drawings for ACS510 drives is located in the ACS510 Technical Reference manual.

Mounting Dimensions

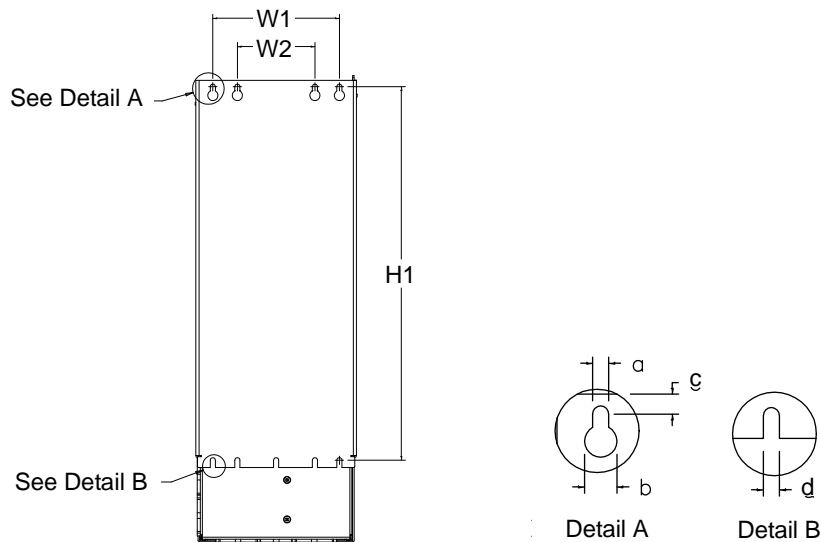

X0032

IP21 and IP54 – Dimensions for each Frame Size												
Ref.	R1		R2		R3		R4		R5		R6	
	mm	in	mm	in	mm	in	mm	in	mm	in	mm	in
W1*	98.0	3.9	98.0	3.9	160	6.3	160	6.3	238	9.4	263	10.4
W2*	--	--	--	--	98.0	3.9	98.0	3.9	--	--	--	--
H1*	318	12.5	418	16.4	473	18.6	578	22.8	588	23.2	675	26.6
a	5.5	0.2	5.5	0.2	6.5	0.25	6.5	0.25	6.5	0.25	9.0	0.35
b	10.0	0.4	10.0	0.4	13.0	0.5	13.0	0.5	14.0	0.55	14.0	0.55
c	5.5	0.2	5.5	0.2	8.0	0.3	8.0	0.3	8.5	0.3	8.5	0.3
d	5.5	0.2	5.5	0.2	6.5	0.25	6.5	0.25	6.5	0.25	9.0	0.35

* Center to center dimension.

Outside Dimensions

Drives with IP21 Enclosures

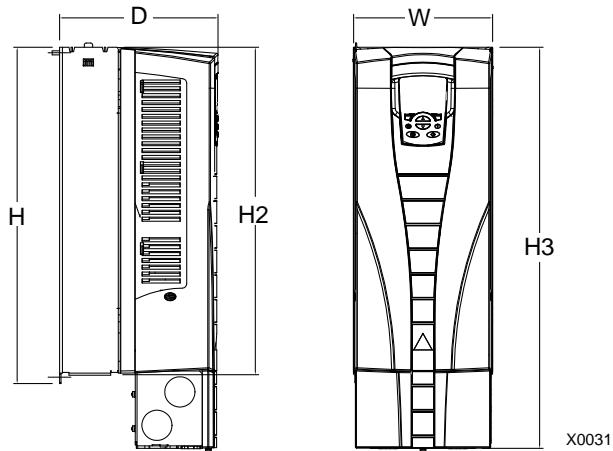

IP21 – Dimensions for each Frame Size							
Ref.	R1	R2	R3	R4	R5	R6	R6 ¹⁾
W (mm)	125	125	203	203	265	300	302
H (mm)	330	430	490	596	602	700	700
H2 (mm)	315	415	478	583	578	698	700
H3 (mm)	369	469	583	689	736	880	986
D (mm)	212	222	231	262	286	400	400

¹⁾ The dimensions apply to ACS510-01-246A-4 and ACS510-01-290A-4

Drives with IP54 Enclosures

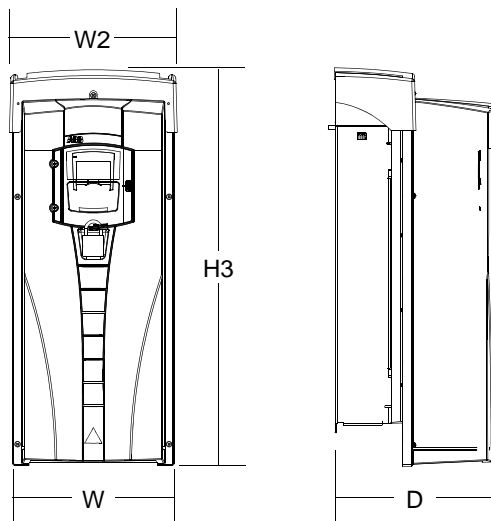

IP54 – Dimensions for each Frame Size							
Ref.	R1	R2	R3	R4	R5	R6	R6 ¹⁾
W (mm)	213	213	257	257	369	410	410
W2 (mm)	222	222	267	267	369	410	410

IP54 – Dimensions for each Frame Size							
Ref.	R1	R2	R3	R4	R5	R6	R6 ¹⁾
H3 (mm)	461	561	629	760	775	926	1119
D (mm)	234	245	254	285	309	423	423

¹⁾ The dimensions apply to ACS510-01-246A-4 and ACS510-01-290A-4

Weight

The following table lists typical maximum weights for each frame size. Variations within each frame size (due to components associated with voltage/current ratings, and options) are minor.

Enclosure	Weight (kg)						
	R1	R2	R3	R4	R5	R6	R6 ¹⁾
IP21	6.5	9.0	16	24	34	69	73
IP54	8.2	11.2	18.5	26.5	38.5	80	84

¹⁾ The weights apply to ACS510-01-246A-4 and ACS510-01-290A-4

Degrees of Protection

Available enclosures:

- IP21 enclosure. The site must be free of airborne dust, corrosive gases or liquids, and conductive contaminants such as condensation, carbon dust, and metallic particles.
- IP54 enclosure. This enclosure provides protection from airborne dust and light sprays or splashing water from all directions.

Compared to the IP21 enclosure, the IP54 enclosure has:

- The same internal plastic shell as the IP21 enclosure
- A different outer plastic cover
- An additional internal fan to improve cooling
- Larger dimensions
- The same rating (does not require a derating)

Ambient Conditions

The following table lists the ACS510 environmental requirements.

Ambient Environment Requirements		
	Installation Site	Storage and Transportation in the protective package
Altitude	<ul style="list-style-type: none"> 0...1000 m (0...3,300 ft) 1000...2000 m (3,300...6,600 ft) if P_N and I₂ derated 1% every 100 m above 1000 m (300 ft above 3,300 ft) 	
Ambient temperature	<ul style="list-style-type: none"> Min. -15 °C (5 °F) – no frost allowed Max. (fsw = 1 or 4) 40 °C (104 °F); 50 °C (122 °F) if P_N and I₂ derated to 90% Max. (fsw = 8) 40 °C (104 °F) if P_N and I₂ derated to 80% Max. (fsw = 12) 30 °C (86 °F) if P_N and I₂ derated to 65% 	-40...70 °C (-40...158 °F)
Relative humidity	< 95% (non-condensing)	
Contamination levels (IEC 721-3-3)	<ul style="list-style-type: none"> No conductive dust allowed. The ACS510 should be installed in clean air according to enclosure classification. Cooling air must be clean, free from corrosive materials and free from electrically conductive dust. Chemical gases: Class 3C2 Solid particles: Class 3S2 	Storage <ul style="list-style-type: none"> No conductive dust allowed. Chemical gases: Class 1C2 Solid particles: Class 1S2 Transportation <ul style="list-style-type: none"> No conductive dust allowed. Chemical gases: Class 2C2 Solid particles: Class 2S2

The following table lists the standard stress testing that the ACS510 passes.

Stress Tests		
	Without Shipping Package	Inside Shipping Package
Sinusoidal vibration	Mechanical conditions: In accordance with IEC 60721-3-3, Class 3M4 <ul style="list-style-type: none"> 2...9 Hz 3.0 mm (0.12 in) 9...200 Hz 10 m/s² (33 ft/s²) 	In accordance with ISTA 1A and 1B specifications.
Shock	Not allowed	In accordance with IEC 68-2-29: max. 100 m/s ² (330 ft/s ²), 11ms
Free fall	Not allowed	<ul style="list-style-type: none"> 76 cm (30 in), frame size R1 61 cm (24 in), frame size R2 46 cm (18 in), frame size R3 31 cm (12 in), frame size R4 25 cm (10 in), frame size R5 15 cm (6 in), frame size R6

Materials

Material Specifications	
Drive enclosure	<ul style="list-style-type: none"> • PC/ABS 2.5 mm, color NCS 1502-Y or NCS 7000-N • Hot-dip zinc coated steel sheet 1.5...2 mm, thickness of coating 20 micrometers. If the surface is painted, the total thickness of the coating (zinc and paint) is 80...100 micrometers. • Cast aluminium AlSi • Extruded aluminium AlSi
Package	Corrugated board, expanded polystyrene, plywood, raw wood (heat dried). Package wrap consists of one or more of the following: PE-LD plastic wrap, PP or steel bands.
Disposal	<p>The drive contains raw materials that should be recycled to preserve energy and natural resources. The package materials are environmentally compatible and recyclable. All metal parts can be recycled. The plastic parts can either be recycled or burned under controlled circumstances, according to local regulations. Most recyclable parts are marked with recycling marks.</p> <p>If recycling is not feasible, all parts excluding electrolytic capacitors and printed circuit boards can be landfilled. The DC capacitors contain electrolyte and, if the drive is not provided with the RoHS marking, the printed circuit boards contain lead, both of which will be classified as hazardous waste within the EU. They must be removed and handled according to local regulations.</p> <p>For further information on environmental aspects and more detailed recycling instructions, please contact your local ABB distributor.</p>

Applicable Standards

Drive compliance with the following standards is identified by the standards “marks” on the type code label.

Mark	Applicable Standards	
	EN 50178 (1997)	Electronic equipment for use in power installations
	IEC/EN 60204-1 (2005)	Safety of machinery. Electrical equipment of machines. Part 1: General requirements. <i>Provisions for compliance:</i> The final assembler of the machine is responsible for installing: <ul style="list-style-type: none"> • An emergency-stop device • A supply disconnecting device
	IEC/EN 60529 (2004)	Degrees of protection provided by enclosures (IP code)
	IEC 60664-1 (2002)	Insulation coordination for equipment within low-voltage systems. Part 1: Principles, requirements and tests
	IEC/EN 61800-5-1 (2003)	Adjustable speed electrical power drive systems. Part 5-1: Safety requirements. Electrical, thermal and energy
	IEC/EN 61800-3 (2004)	Adjustable speed electrical power drive systems. Part 3: EMC requirements and specific test methods

Compliance is valid with the following provisions:

- The motor and control cables are chosen as specified in this manual.
- The installation rules of this manual are followed.

EMC

This section describes conformance with EMC requirements.

CE Marking

When a CE mark is attached to the ACS510 AC drive, it verifies that the drive follows the provisions of the European Low Voltage and EMC Directives (Directive 73/23/EEC, as amended by 93/68/EEC and Directive 89/336/EEC, as amended by 93/68/EEC). The corresponding declarations are available on request and can be found using the internet at: <http://www.abb.com>.

The EMC Directive defines the requirements for immunity and emissions of electrical equipment used in European Economic Area. The EMC product standard EN 61800-3 covers the requirements stated for drives, such as the ACS510. The drive complies with the First environment (restricted distribution) and Second Environment limits of EN/IEC 61800-3.

Electromagnetic Environments

Product standard EN 61800-3 (Adjustable speed electrical power drive systems - Part 3: EMC product standard including specific test methods) defines **First Environment** as environment that includes domestic premises. It also includes establishments directly connected without intermediate transformers to a low voltage power supply network which supplies buildings used for domestic purposes.

Second Environment includes establishments other than those directly connected to a low voltage power supply network which supplies buildings used for domestic purposes.

Liability Limits

The manufacturer is not responsible for:

- Any costs resulting from a failure if the installation, commissioning, repair, alteration, or ambient conditions of the drive do not fulfil the requirements specified in the documentation delivered with the unit and other relevant documentation.
- Units subjected to misuse, negligence or accident.
- Units comprised of materials provided or designs stipulated by the purchaser.

In no event shall the manufacturer, its suppliers or subcontractors be liable for special, indirect, incidental or consequential damages, losses or penalties.

If you have any questions concerning your ABB drive, please contact the local distributor or ABB office. The technical data, information and specifications are valid at the time of printing. The manufacturer reserves the right to modifications without prior notice.

Index

Numerics

0xxxx register	
EFB function codes	157
EFB mapping	155
1xxxx register	
EFB function codes	158
EFB mapping	157
3-wire macro	43
3xxxx register	
EFB function codes	158
EFB mapping	158
4xxxx register	
EFB function codes	160
EFB mapping	158

A

ABB standard (default) macro	42
acceleration	
/deceleration, parameter group	94
at aux. stop (PFC), parameter	140
ramp select, parameter	94
ramp shape, parameter	94
ramp time (PFC), parameter	140
ramp zero select, parameter	95
time, parameter	94
activate (external PID), parameter	121
actual input (PID), parameters	117
actual max. (PID), parameters	117
actual min. (PID), parameters	117
actual values	
mapping, FBA, generic profile	194
scaling, EFB comm	150
scaling, FBA	182
scaling, FBA, ABB drives profile	192
scaling, FBA, generic profile	194
alarm	
codes	202
codes (Basic control panel)	204
enable display, parameter	87
listing	202
words, data parameters	69
alternate macro	44
altitude	
derating	212
environment limit	234
shipping limit	234
analog cable	
requirements	229
analog I/O	
connections	17
specifications	17

analog input	
data parameter	65
fault limit, parameters	102
filter, parameters	78
less than min. auto. reset, parameter	104
less than min., fault parameter	100
loss, fault codes	197
maximum, parameters	78
minimum, parameters	78
parameter group	78
ref. correction formula	74
analog output	
content max., parameters	82
content min., parameters	82
current max., parameters	82
current min., parameters	82
data content, parameters	82
data parameter	66
filter, parameters	82
parameter group	82
application block output, data parameter	65
application macro, parameter	63
application macros	
see macros	
Assistant control panel	
see control panel (Assistant)	
autochange	
interval, parameter	133
level, parameter	134
overview	134
starting order counter	134
automatic reset	
see reset, automatic	
auxiliary motor	
see motor, auxiliary	

B

backing up parameters (Assistant panel)	32
backing up parameters (Basic panel)	39
braking	
components	224
protection from overheated resistor	227
resistor heat dissipation	226
selecting brake choppers/resistors	224
wiring	226
break point frequency, fault parameter	101

C

cable requirements	
grounding	215
input power	214
motor	220
CE marking	236
changed parameters (Assistant panel)	32
chopper	
see braking	

CISPR11 class A			
radiation limits	221		
CISPR11 class B			
radiation limits	222		
comm			
config file CPI firmware revision, parameter	123		
config file id revision, parameter	123		
config file revision, parameter	123		
fault function, parameter	102		
fault time, parameter	102		
fieldbus CPI firmware revision, parameter	123		
fieldbus parameter refresh, parameter	123		
fieldbus parameters	123		
fieldbus status, parameter	123		
fieldbus type, parameter	123		
protocol select, parameter	141		
relay output word, data parameter	66		
values, data parameter	66		
comm (EFB)			
actual value scaling	150		
actual values	150		
analog output control, activate	148		
comm fault response	149		
configuration	145		
configure for loss of communication	152		
control interface	142		
control word	162		
diagnostics	151		
drive control of functions, activate	146		
exception codes	161		
fault code 28	153		
fault code 31	153		
fault code 32	153		
fault code 33	153		
fault tracing parameters	151		
fault, duplicate stations	152		
fault, intermittent off-line	153		
fault, no master station on line	152		
fault, swapped wires	152		
feedback from drive	150		
input ref. sel., activate	147		
installation	143		
misc. drive control, activate	147		
modbus actual values	161		
normal operation	152		
overview	142		
PID control setpoint source, activate	149		
planning	143		
profiles	155		
reference scaling, ABB drives profile	171		
relay output control, activate	148		
set-up	144		
start/stop control, activate	146		
state diagram	170		
status word	165		
termination	144		
comm (FBA)			
actual values	176		
analog output control, activate	180		
comm fault response	181		
configuration	178		
control interface	175		
control word	175		
control word, ABB drives	185		
diagnostics	182		
drive feedback	181		
fieldbus control, activate	178		
input ref. sel., activate	179		
installation	177		
overview	174		
PID control setpoint source, activate	181		
planning	176		
protocol listing	174		
reference	176		
relay output control, activate	180		
set-up	178		
start/stop control, activate	178		
state diagram, ABB drives	188		
status word	176		
status word, ABB drives	186		
conduit			
kit	13		
config file			
CPI firmware revision, parameter	123		
id revision, parameter	123		
revision, parameter	123		
connections			
control	17		
diagram	17		
EFB comm	143		
FBA module	177		
X1	17		
constant speed			
see speed, constant			
construction code	9		
contamination levels			
environment limit	234		
shipping limit	234		
contrast, control panel	28		
control			
connection specifications	228		
location, data parameter	65		
reference (Assistant panel)	30		
shaft direction	30		
start/stop	30		
terminal specifications	229		
control cable			
connections	17		
requirements	228		

control panel	27
cable requirements	229
comm error, fault parameter	100
contrast	28
display bar-graph	108
display contrast	28
display decimal point (form), parameters	108
display max., parameters	108
display min., parameters	108
display process variables, parameter group	108
display selection, parameters	108
display units, parameters	108
parameter lock, parameter	84
pass code, parameter	84
reference control, parameter	73
signal max., parameters	108
signal min., parameters	108
soft keys	28
control panel (Assistant)	27
changed parameters mode	32
controls overview	28
fault logger mode	32
I/O settings mode	34
main menu	30
output mode	28
parameter backup mode	32
parameters mode	30
rotating arrow	29
soft key	28
control panel (Basic)	
alarm codes	204
controls overview	36
output mode	36
parameter backup mode	39
parameters mode	38
control word	
ABB drives, FBA, description	185
comm (EFB), description	162
FBA	175
FBA generic profile	193
controls overview (Assistant panel)	28
controls overview (Basic panel)	36
cooling	
air flow	229
heat loss	229
space requirement	229
correction source (PID), parameter	122
cover	
remove	11
replace	24
critical speeds (avoiding)	
high, parameters	96
low, parameters	96
parameter group	96
select, parameter	96
current	
at fault, history parameter	70
data parameter	65
max. limit, parameter	91
measurement, fault code	198
rating code	9

D

dc brake time, parameter	92
dc bus voltage, data parameter	65
dc current ref., parameter	92
DC magnetizing time, parameter	92
DC overvoltage, fault code	196
DC undervoltage, fault code	197
deceleration	
at aux. start (PFC), parameter	140
emergency time, parameter	94
parameter group	94
ramp select, parameter	94
ramp shape, parameter	94
ramp time (PFC), parameter	140
ramp zero select, parameter	95
time, parameter	94
default macro	42
default values	
listing for macros	50
listing for parameters	51
derating	
adjustment example	212
altitude	212
switching frequency	212
temperature	212
derivation time (PID), parameter	114
device overtemperature, fault code	196
diagnostics	195
EFB comm	151
FBA comm	182
differences list, downloads	34
digital cable	
requirements	229
digital input	
at fault, history parameters	70
connections	17
specifications	17
status, data parameter	65
digital output	
connections	17
specifications	228
dimensions	
drive, mounting	231
drive, outside	232
direction	
control	30
control, parameter	72
display format (PID), parameter	114
disposal	235
download	
failure	34
handling inexact transfers	33, 40
parameter sets	32

drive			
EFB comm installation	143		
FBA module installation	177		
id, fault code	198		
mounting	12		
mounting dimensions	231		
outside dimensions	232		
rating, parameter	107		
temperature, data parameter	65		
weight	233		
drive on time, data parameters	67		
		E	
earth fault			
fault code	198		
parameter	102		
earthing			
see ground			
EFB			
baud rate, parameter	124		
config file, fault code	198		
control profile, parameter	124		
CRC errors (count), parameter	124		
fault codes	198		
ok messages (count), parameter	124		
parameters	124, 125		
parity, parameter	124		
protocol id, parameter	124		
protocol, parameter group	124		
station id, parameter	124		
status, parameter	124		
UART errors (count), parameter	124		
efficiency	229		
EM3 screw	216		
embedded field bus			
see EFB			
EMC			
CE marking	236		
motor cable requirements	220		
emergency			
deceleration time, parameter	94		
stop devices	214		
stop select, parameter	93		
EN 61800-3 first environment			
restricted distribution radiation limits	221		
unrestricted distribution radiation limits	222		
enclosure			
types	233		
enclosure protection class code	9		
environment			
first, definition	236		
second, definition	236		
error value inversion (PID), parameter	114		
exception codes, EFB modbus	161		
external comm module, parameter group	123		
external commands selection, parameter	71		
external control selection, parameter	73		
external fault			
automatic reset, parameter	104		
fault codes	197		
parameters	100		
external reference, data parameter	65		
		F	
fan maintenance	207		
fault			
codes	196		
comm (FBA)	181		
comm failure (EFB)	149		
current at, history parameter	70		
digital input status at, history parameter	70		
frequency at, history parameter	70		
functions, parameter group	100		
history	201		
history, parameter group	70		
last, history parameter	70		
listing	196		
previous, history parameter	70		
reset	200		
reset select, parameter	84		
speed at, history parameter	70		
status at, history parameter	70		
time of, history parameters	70		
torque at, history parameter	70		
voltage at, history parameter	70		
words, data parameters	69		
fault code			
28 serial 1 err	153		
fault logging (Assistant panel)	32		
FB actual signals, parameter group	68		
feedback multiplier (PID), parameter	116		
feedback select (PID), parameter	116		
field weakening point	219		
fieldbus			
see comm			
command words, data parameters	68		
CPI firmware revision, parameter	123		
parameter refresh, parameter	123		
parameters	123		
status words, data parameters	68		
status, parameter	123		
type, parameter	123		
fieldbus adapter			
see comm (FBA)			
firmware test date, parameter	107		
firmware version, parameter	107		
first environment, definition	236		
floating network			
connections	216		
warning about filters	222, 223		
warning about screws at EM1, EM3	15		
warning about screws at F1, F2	16		
flux braking, parameter	97		
flux optimization, parameter	97		
force trip, fault code	198		
frame size	210		
free fall			
stress testing	234		
frequency			
at fault, history parameter	70		
max. limit, parameter	91		
min. limit, parameter	91		
motor, resolution	219		
motor, specification	219		
switching, parameter	98		

fuses			
380...480 volt drives	214		
		G	
gain (PID), parameter	113		
generic profile			
actual value mapping	194		
actual value scaling	194		
overview	193		
reference scaling	193		
technical data	193		
gland kit	13		
ground			
cable/wire requirements	215		
fault protection	219		
		H	
hand-auto macro	46		
heat loss	229		
		I	
I/O settings (Assistant panel)	34		
IEC ratings			
see ratings			
impedance grounded network			
see floating network			
information			
parameter group	107		
input power			
cable/wire requirements	214		
disconnect device	213		
specifications	213		
input power connection			
floating networks			
lugs for R6	217		
terminal size	217		
torque	217		
installation			
check list	23		
compatibility	9		
environment	10		
flow chart	7		
location	10		
mounting drive	12		
preparation	8		
procedures	7		
tools	9		
wiring overview	13		
insulation			
check	18		
integration time (PID), parameter	114		
interlocks			
parameter	135		
internal setpoint (PID), parameter	116		
IR compensation			
frequency, parameter	97		
parameters	97		
voltage, parameter	97		
IT network			
see floating network			
		K	
keypad			
see control panel			
keypad reference select, parameter	73		
kWh counter, data parameter	65		
		L	
label			
serial number	8		
type code	8		
language, parameter	63		
liability limits	236		
limits, parameter group	91		
load package version, parameter	107		
LOC/REM			
Assistant panel	29		
Basic panel	37		
local control	29		
local mode			
lock, parameter	85		
lock			
control panel access, IP54	24		
drive control at local control panel	85		
parameters	84		
low frequency (PFC), parameters	131		
lugs for R6 power cables	217		
		M	
macros			
3-wire	43		
ABB standard (default)	42		
alternate	44		
hand-auto	46		
motor potentiometer	45		
parameter default values	50		
parameters not changed			
PFC	48, 49		
PID control	47		
main menu			
control panel (Assistant)	30		
mains			
see input power			
maintenance			
capacitors	208		
control panel	209		
heat sink	206		
internal enclosure fan	208		
intervals	206		
main fan	207		
manuals	2		
mapping			
actual value, FBA, generic profile	194		
EFB modbus	155		
materials	235		
maximum			
frequency, parameter	91		
minimum			
frequency, parameter	91		

PID			
0% (actual signal), parameter	115		
100% (actual signal), parameter	115		
actual input select, parameters	117		
actual value max., parameters	117		
actual value min., parameters	117		
adjustment procedure	113		
control macro	47		
correction source, parameter	122		
decimal point (actual signal), parameter	114		
derivation filter, parameter	114		
derivation time, parameter	114		
deviation, data parameter	66		
error feedback inversion, parameter	114		
external / trimming, parameter group	121		
external source activate, parameter	121		
feedback multiplier, parameter	116		
feedback select, parameter	116		
feedback, data parameter	66		
gain, parameter	113		
integration time, parameter	114		
internal setpoint, parameter	116		
offset, parameter	121		
output, data parameter	66		
parameter set select, parameter	119		
process sets, parameter groups	112		
scaling (0%...100%), parameters	115		
setpoint maximum, parameter	116		
setpoint minimum, parameter	116		
setpoint select, parameter	115		
setpoint source, EFB comm activate	149		
setpoint source, FBA comm, activate	181		
setpoint, data parameter	66		
sleep delay, parameter	118		
sleep level, parameter	118		
sleep selection, parameter	118		
trim mode, parameter	121		
trim scale, parameter	121		
units (actual signal), parameter	114		
wake-up delay, parameter	118		
wake-up deviation, parameter	118		
PID controller			
advanced set-up	113		
basic set-up	112		
planning			
EFB comm	143		
FBA comm	176		
PNP	18		
power			
data parameter	65		
first applied	25		
previous faults, history parameters	70		
process PID sets, parameter groups	112		
process variables, data parameter	66		
profiles			
comm (EFB)	155		
protection			
circuit, required w/ chopper	227		
disconnect device	213		
enclosure standard	235		
environmental	233		
PT100 temperature sensor	111		
PTC temperature sensor	111		
pump fan control			
see PFC			
		R	
		radiation limits, conducted	
		EN 61800-3	221
		ramp pair (accel/decel), parameter	94
		range	
		listing for parameters	51
		ratings	210
		reference	
		analog input corrections	74
		corrections for parameter values	74
		keypad control, parameter	73
		maximum, parameters	75
		minimum, parameters	75
		select source, parameter	73
		select, parameter group	73
		speed/frequency control (Assistant panel)	30
		reference scaling	
		EFB, ABB drives profile	171
		FBA, ABB drives profile	189
		FBA, generic profile	193
		reference step (PFC), parameters	130
		regulator by-pass control, parameter	139
		relative humidity	
		environment limit	234
		shipping limit	234
		relay output	
		activation condition parameters	79
		off-delay, parameters	80
		on-delay, parameters	80
		parameter group	79
		status, data parameter	66
		relays, specifications	228
		remote control	29
		remove cover	11
		reset, automatic	
		analog input less than min., parameter	104
		delay time, parameter	104
		external fault, parameter	104
		number of trials, parameter	104
		overcurrent, parameter	104
		parameter group	
		trial time, parameter	104
		undervoltage, parameter	104
		resolution	
		listing for parameters	51
		resonance (avoiding)	
		select, parameter	96
		revolution counter, data parameter	67
		rotating arrow, control panel	29
		RS485 comm	143
		run enable	
		source select, parameter	84
		run time, data parameter	65, 67
			S
		safety	3
		save changes parameter	85

scaling	
actual value, FBA, ABB drives profile	192
actual value, FBA, generic profile	194
actual values, EFB comm	150
reference (EFB, ABB drives profile)	171
reference, FBA, ABB drives profile	189
reference, FBA, generic profile	193
s-curve ramp, parameter	94
sensor type, parameter	111
serial 1 error (fault code 28)	153
serial 1 error, fault code	198
serial communication	
see comm	
serial number	8
setpoint maximum (PID), parameter	116
setpoint minimum (PID), parameter	116
setpoint select (PID), parameter	115
shock	
stress testing	234
short circuit, fault code	197
single phase supply	
connection	13
sleep selection (PID), parameter	118
slip compensation ratio, parameter	98
soft key	28
soft keys, control panel	28
specifications	
control connections	228
input power	213
mains	213
motor connections	219
speed	
at fault, history parameter	70
data parameter	65
speed, constant	
digital input selection parameter	76
parameter	77
parameter group	76
stall	
frequency, fault parameter	101
function, fault parameter	101
region	101
time, fault parameter	101
standards	235
CE marking	236
EN 50178	235
EN 60204-1	235
EN 60529	235
EN 61800-3	235, 236
IEC 60664-1	235
start	
aux. motor (PFC), parameters	130
aux. motor delay	131
control	30
control, EFB comm	146
control, FBA comm	178
DC magnetizing time, parameter	92
delay (PFC), parameter	139
frequency (PFC), parameters	130
function, parameter	92
inhibit, parameter	92
parameter group	92
select enable source, parameter	86
torque boost current, parameter	93
start mode	
automatic	92
automatic torque boost	92
DC magnetizing	92
flying start	92
start/stop, parameter group	92
start/stop/dir, parameter group	71
starting order counter	134
start-up	
macros	25
motor data	25
tuning	26
start-up data, parameter group	63
state diagram	
comm (EFB)	170
comm, ABB drives	188
status at fault, history parameter	70
status word	
ABB drives, FBA, description	186
comm (EFB), definition	165
FBA	176
FBA generic profile	193
stop	
aux. motor (PFC), parameters	131
aux. motor delay	131
control	30
dc brake time, parameter	92
DC current control, parameter	92
dc current ref., parameter	92
emergency devices	214
emergency select, parameter	93
flux braking, parameter	97
function, parameter	92
parameter group	92
supervision	
parameter group	105
parameter low limit, parameters	105
parameter selection, parameters	105
supply phase, fault code	198
switching frequency	219
derating	212
switching frequency control, parameter	98
switching frequency, parameter	98
symmetrically grounded network	216
system controls, parameter group	84
T	
temperature derating	212

terminals	
control, description	17
control, specifications	229
location diagram, R1...R4	15
location diagram, R5/R6	16
termination	144
test date, parameter	107
thermal fail, fault code	198
tools	9
torque	
at fault, history parameter	70
boost current, parameter	93
data parameter	65
trim mode (PID), parameter	121
trim scale (PID), parameter	121
type code	8

U

U/f ratio, parameter	98
underload	
curve, fault parameter	102
fault code	198
function, fault parameter	102
time, fault parameter	102
undervoltage	
automatic reset, parameter	104
control enable, parameter	91
ungrounded network	
see floating network	
units (PID), parameter	114
unpacking drive	8
unsymmetrically grounded networks	216
user parameter set	
change control, parameter	85
download	33

V

vibration	
stress testing	234
voltage	
at fault, history parameter	70
rating code	9
voltage/frequency ratio, parameter	98

W

wake-up delay (PID), parameter	118
wake-up deviation (PID), parameter	118
warning	
automatic start up	3, 25
dangerous voltages	3
high temperatures	3
listing	3
not field repairable	3
parallel control connections	3
qualified installer	3
thermistor installation	110
weight	
drive	233

wiring	
control	17
fault, parameter	103
installation	18
installation steps, IP21/cables	19
installation steps, IP21/conduit	20
installation steps, IP54/cables	21
installation steps, IP54/conduit	22
overview	13
requirements, general	13

XYZ

zero speed load, fault parameter	101
----------------------------------	-----

ABB
