

钢格板

Steel Grating



生产设备 Manufacturing Equipment



Contents 目录

产品简介 / 质量标准 Introduction/Quality Standard	01
常用钢格板 Common Steel Gratings	02
钢格板分类 Steel Grating Classified	03
制造工艺 Manufacturing Process	04
公差及表面处理 Tolerance and Surface Treatment	05
订货须知 How to Order	06
广泛应用的钢格板 Application	07
异型钢格板 Grating Tailored	09
重载荷压焊钢格板常用规格及安全荷载表 Common Specification and Safe Load Table for Heavy Duty Steel Gratings	10
平面型扁钢中心间距为 30mm 压焊钢格板常用型号及安全荷载表 Table of Safe Load & General Type of Steel Grating With Bearing Bar Pitch at 30mm	11
平面型扁钢中心间距为 40mm 压焊钢格板常用型号及安全荷载表 Table of Safe Load & General Type of Steel Grating With Bearing Bar Pitch at 40mm	12
平面型扁钢中心间距 60mm 压焊钢格板常用规格及安全荷载表 Common Specification and Safe Load Table of Steel Grating (Plain Style, Bearing Bars at 60mm Pitch)	13
常用钢格板选型指南 Common Steel Grating Selection Guide	14
I 型钢中心间距为 30mm 压焊钢格板常用规格及安全荷载表 Common Specification and Safe Load Table of Steel Grating (I Style, Bearing Bars at 30mm Pitch)	15
I 型钢中心间距为 40mm 压焊钢格板常用规格及安全荷载表 Common Specification and Safe Load Table of Steel Grating (I Style, Bearing Bars at 40mm Pitch)	16
钢格板安装 Installation of Steel Grating	17
钢梯 Steel Ladder	19
钢梯踏步板 Steel Ladders and Stair Treads	20
吊顶 Ceiling	21
沟盖板 Trench Cover Grating	22
GM 型井孔钢格板盖 GM Type – Steel Grating Manhole	23
水槽 Water Channel Grating	25
其它产品 Other Products	26
球节点钢管栏杆 Ball Joint Handrail	27
包装与运输 Packaging and Transportation	29

产品简介 / 质量标准 Introduction / Quality Standard

钢格板标记 / Symbol of Steel Grating

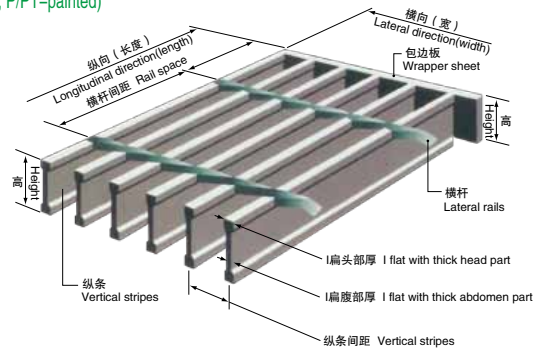
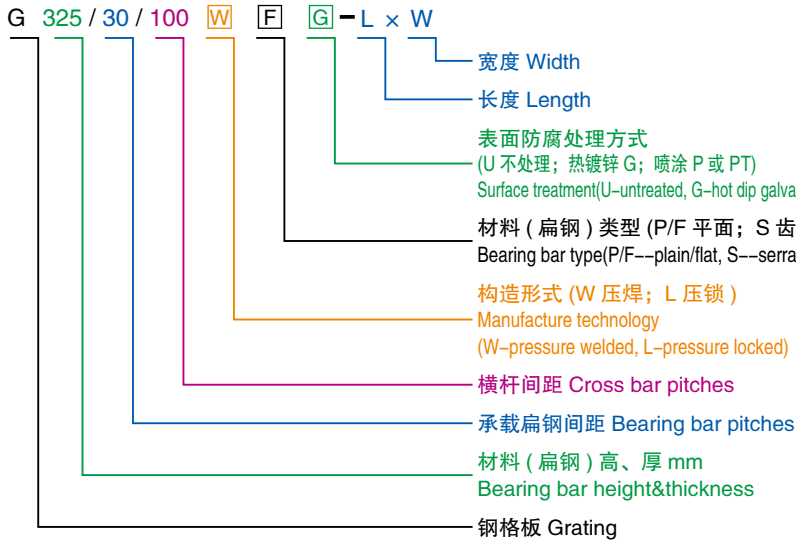

注:

- 扁钢中心间距有15、20、25、30、33、35、38、40、50、60、80、90mm等, 推荐采用25、30、35、40mm。
- 横杆中心间距, 从30-100mm任意选用, 推荐采用50、76、100mm。
- 扁钢外形标记:
F-表示为平面型扁钢(在标记中可省略); S-表示为齿形扁钢;
I-表示为截面为“1”型扁钢。
- 表面处理标记: G-表示热镀锌
P-表示涂漆;
U-表示表面不作处理

Note:

- Bearing bar pitches may be 15 to 20、25、30、33、35、38、40、50、60、80、90mm, of which 25、30、35 and 40mm are recommended.
- Cross bar pitches may be 30-100mm, of which 50mm, 76mm and 100mm are recommended.
- Sign of the shape of bearing bars:
F-Plainstyle (may be omitted in the symbol of steel grating)
S-serrated style
I-I-section style
IS-I-section serrated style
- Sign of surface-treatment:
G-Hot Galvanizing(may be omitted in the symbol of steel grating)
P-Painted
U-Untreated

质量标准 / Quality Standard

钢材标准 Steel Product Standard	
中国 GB/T 700-2006	CHINA GB/T 700-2006
热镀锌标准 Hot Galvanizing Standard	
中国 GB/T 13912-2002	CHINA GB/T 13912-2002
钢格板标准 Steel Grating Standards	
中国 YB/T4001.1-2007	CHINA YB/T4001.1-2007
澳大利亚 AS1657-2013	Australia AS1657-2013
美国 MBG531-00	U.S.A MBG531-00

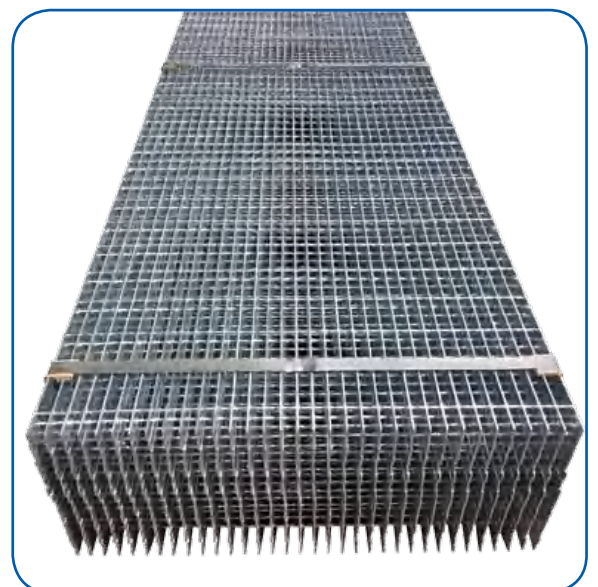

常用钢格板 Common Steel Gratings

此种钢格板在各种市政领域里是常用的。由于扁钢的间距较小，所以它更具有承受力。最适和用在有人的工作平台地板、走道梯踏板。
This type of steel grating is commonly used in the municipal field. The smaller spacing between the bearing bars has ensured heavier loading capacity of the steel grating. It is the best option for platform, walkway and stair treads which always have people to walk on.

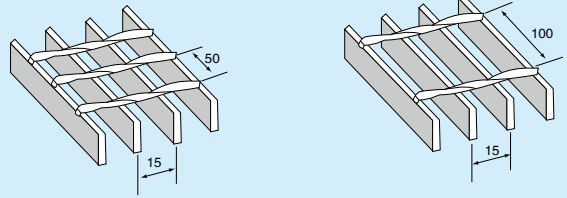

此种钢格板在各工业领域里是常用的，在常用钢格板的品种中，对表面冲击具有最强的抵抗力，尤其横杆间距 50mm 的钢格板具有很强的抗侧冲击的能力。
This type of steel grating is generally used for all sectors of industries. They have excellent performance in resistance to surface impact, especially for the 50mm cross bars space type.

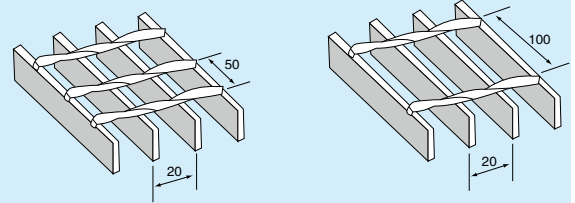

此种钢格板是各工业领域用途最广泛的品种。由于其扁钢间距适中，因此相对更经济轻便。
This type of steel grating is widely used in various of industries. Due to the suitable pitch of bearing bars, it has become more economical with lighter weight.

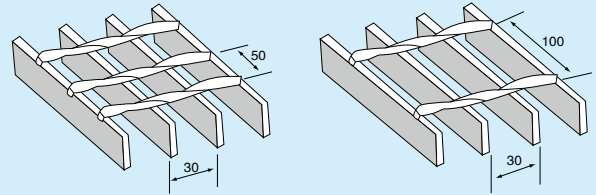

此种钢格板是经济轻便的品种。在跨距小的场合下，是最能满足多方面使用要求的产品。
As the most economical and light-weight type in all gratings, this type of steel grating can meet a variety of uses in case of short spans.

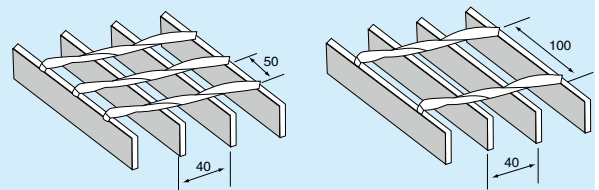

此种钢格板是专为采矿业的应用而开发的品种。常指定用于采矿业的加工厂和转运站的板面。
This type of steel grating has been developed specially for mining industry. It is often used as the floorings of processing plants and transfer stations in mining industry.

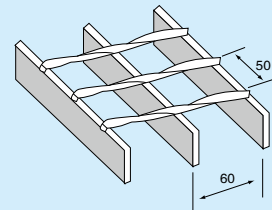

★ 我们也可按照客户要求压焊其它排列组合的钢格板，用来制作围墙、栅栏、厂区大门、机器保护罩等。扁钢间距可取 20-300mm，横杆间距可取 30-100mm。

★ Customized specifications are also available, used as fences, gates and machine guards, etc. Bearing bars pitch can be set from 20mm to 300mm. Cross bars pitch can be set from 30mm to 100mm.

钢格板分类 Steel Grating Classified

按负载扁钢类型分类 / Classified by bearing bars

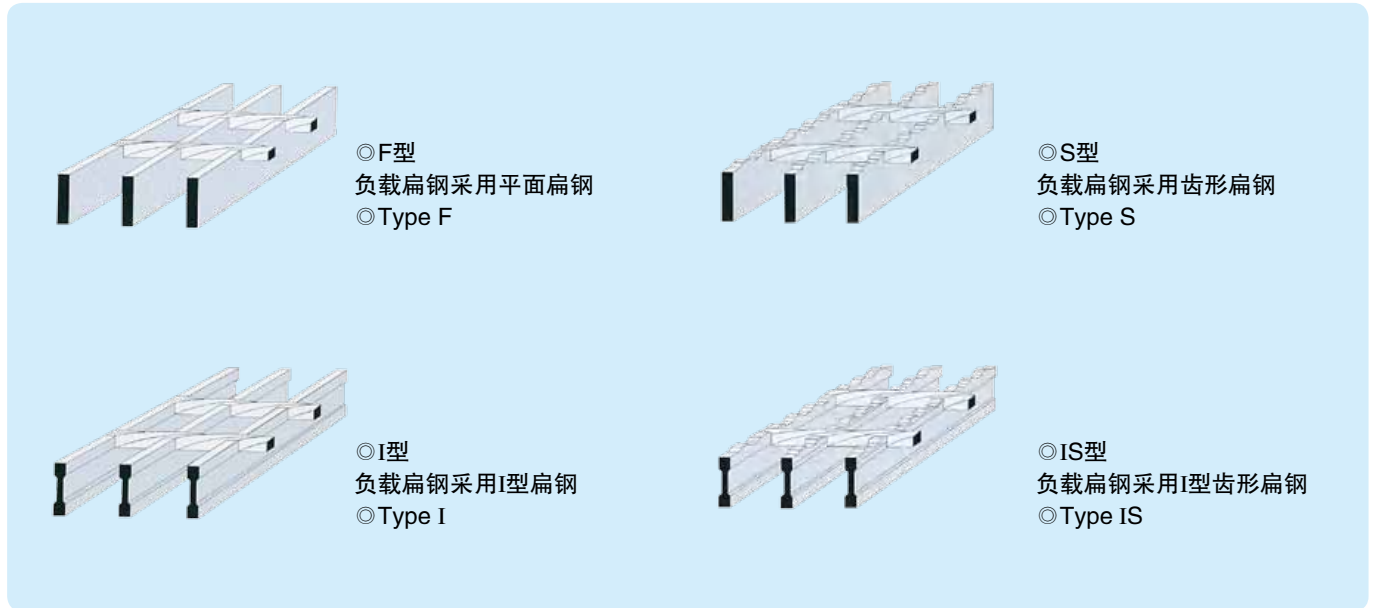

按包边形式分类 / Classified by end plates

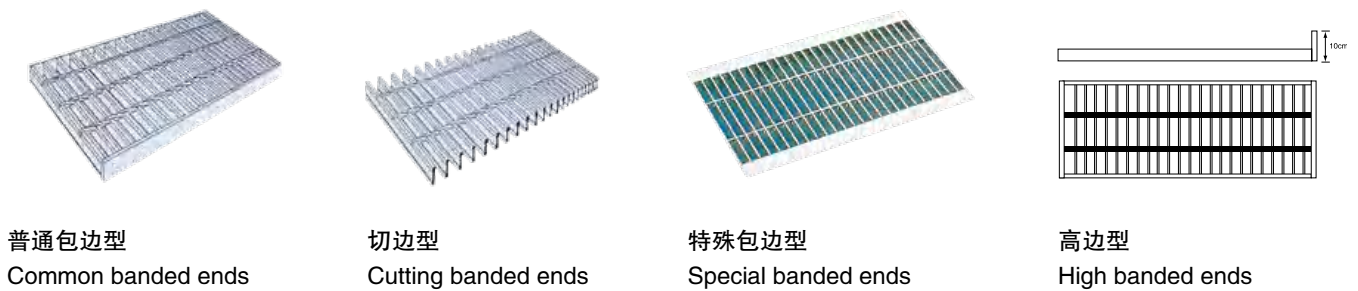

按表面覆板分类 / Classified by surface covering plate

复合钢格板 Composite Steel Grating

复合钢格板是由具有一定横跨能力的钢格板和密封表面的花纹钢格板组合而成的一种产品。它可用任何一种型号的钢格板和不同厚度的花纹钢板构成。

Composite steel grating is made of steel grating with spanning ability covered with checkered plate. They are available for different specifications of steel gratings and with different thickness of checkered plates.

型号标记 Symbol of Type

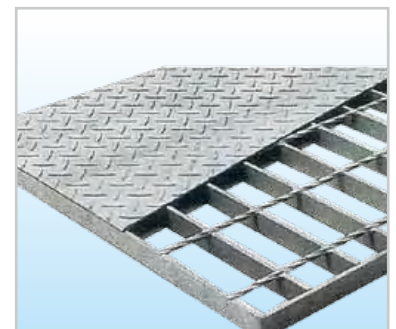
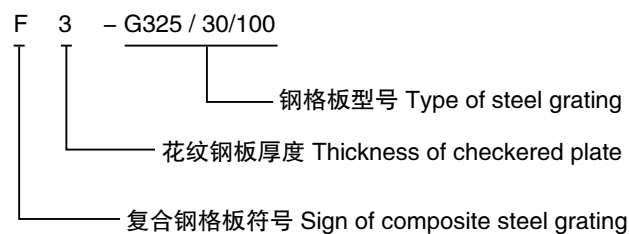

制造工艺 Manufacturing Process

钢格板严格执行产品质量标准，在 ISO9001 质量保证模式控制下，确保其高品质，其制造工艺流程如下：

The steel gratings have been fabricated strictly in accordance with the product standards. The high quality is guaranteed under the control of ISO9001 system. The manufacturing processes are as follows:

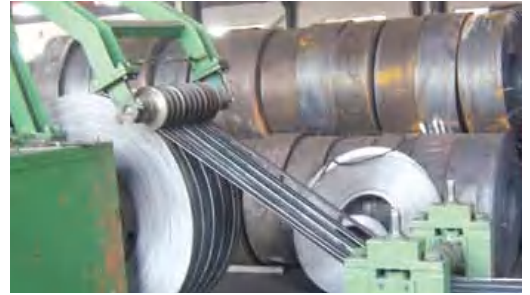
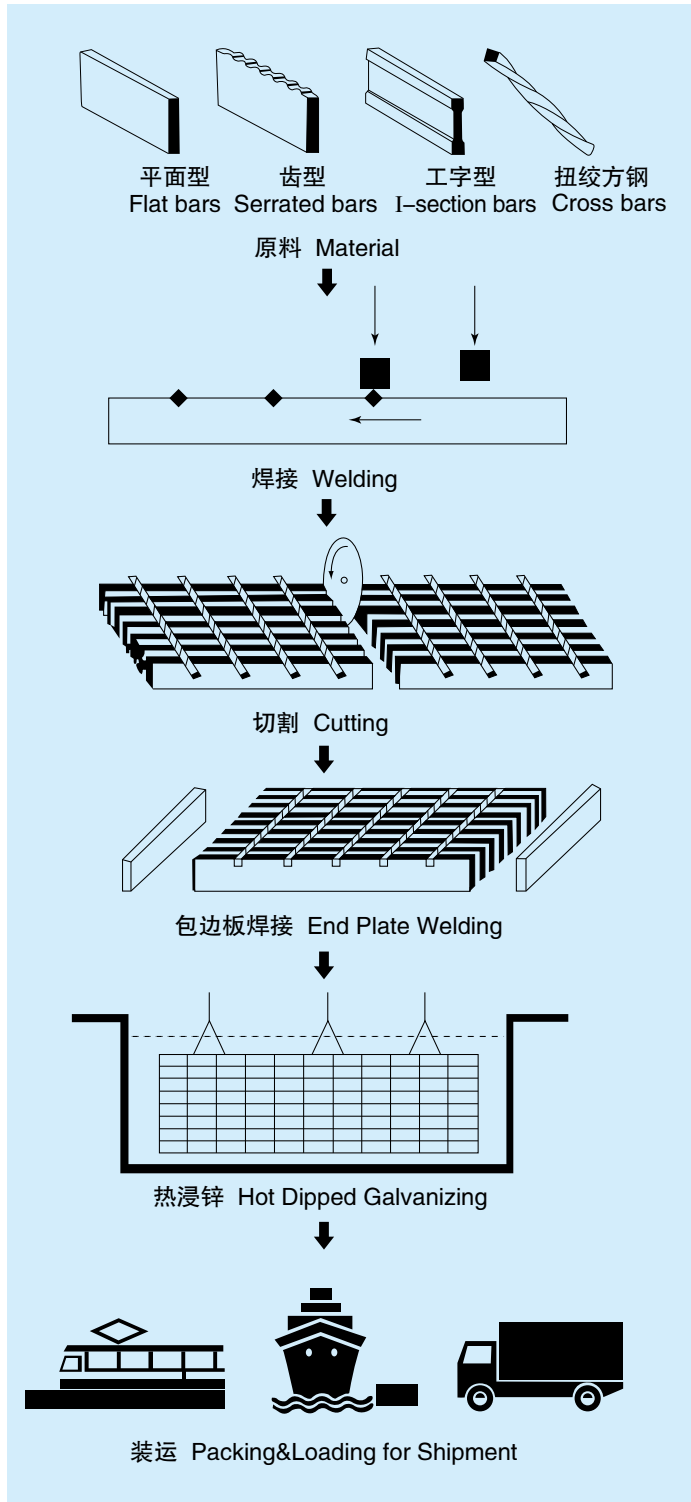

公差及表面处理 Tolerance and Surface Treatment

钢格板公差 / Tolerance of Steel Grating

所有项目的尺寸偏差值均为最大允许量 The tolerance for all items is the maximum value

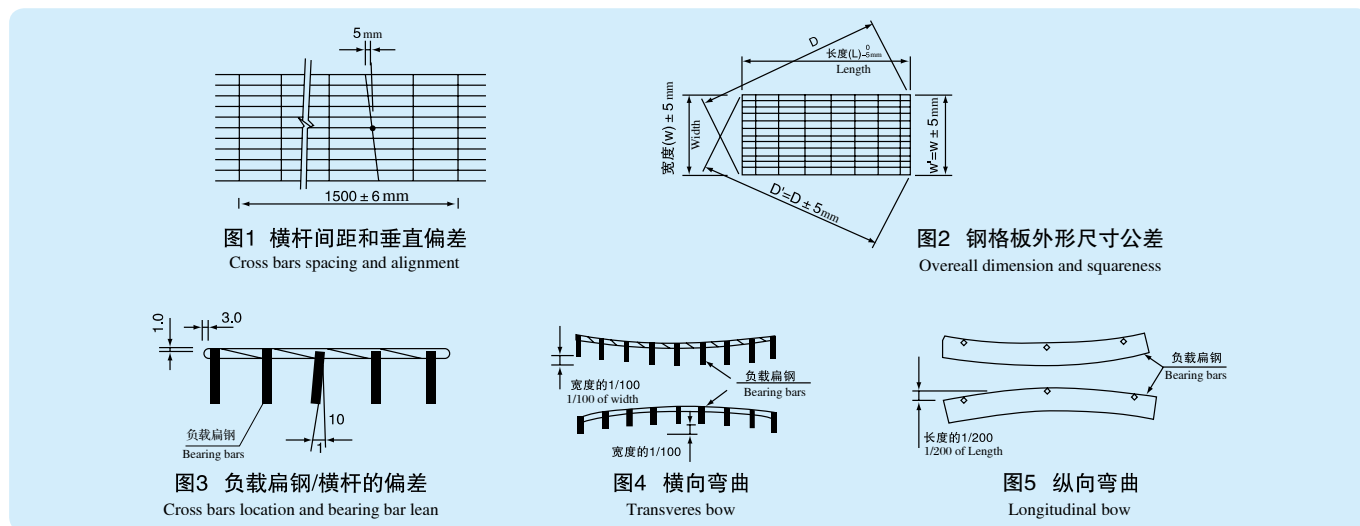

钢格板的表面处理 Surface Treatment

1. 热浸镀锌 Hot-dipped Galvanizing

热浸镀锌一般在包边工作完成后进行。当负载扁钢厚度不小于 5mm 时，镀锌后的平均锌层重量不小于 610g/m^2 ；当负载扁钢厚度小于 5mm 时，镀锌后的平均锌层重量不小于 460g/m^2 ，镀锌后质量及要求应符合 GB/T13912-2002 规定。

Normally, hot-dipped galvanizing will be carried out after end welding process. If the thickness of bearing bars is not less than 5mm, the average weight of Zinc Layer will not be less than 610g/m^2 . If the thickness of bearing bars is less than 5mm, the average weight of Zinc Layer will not be less than 460g/m^2 . The quality of hot-dipped galvanizing should follow up the GB/T13912-2002 standards.

2. 涂漆 Painting

用喷涂、刷涂或浸渍的方法获得保护层。

Gain protection layer through the ways of spraying, brushing and soaking.

3. 不处理 Untreated

热浸镀锌的防腐性能

Anti-corrosive Property of Hot Galvanizing

热浸镀锌使用寿命对比

锌层厚度 $100\ \mu\text{m}$ ，产品在各种环境中的预计寿命。

Life time comparison in different circumstances of $100\ \mu\text{m}$ thick Zinc layer.

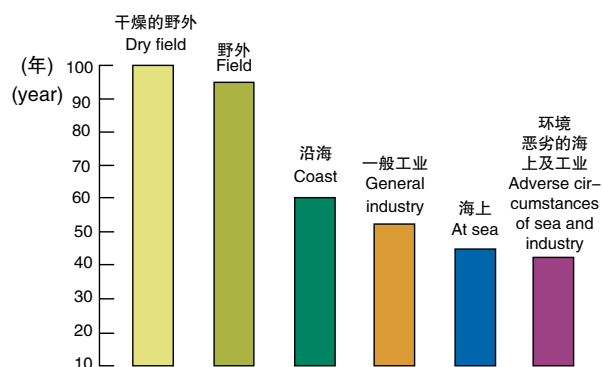

订货须知

How to Order

钢格板重量计算 / Weight of Steel Grating

钢格板的重量是经过包边和表面处理（非表面处理的除外）后的理论重量。由于包边、开孔和切口的不同，实际重量与理论重量会出现差异。在工业平台钢格板自重计算及钢格板交付结算中，统一以理论重量为计算依据。对于长度小于1m的钢格板（例如沟盖板）或者需要作特殊包边的钢格板，由于包边板的增加，重量会随着增加。用扁钢包边，钢格板长度不小于1m时，按下面公式计算钢格板理论重量：

The steel grating weight refers to the theoretical weight after banding and surface treatment (except untreated one). As the banding, pitches and cutting methods are different, actual weight will also be different. When do industrial platform grating weight calculation and engineering settlement, we will do based on theoretical weight. For length < 1 meter grating (such as drainage grating) or grating needed special banding, the weight will increase as the banding be added. For banding with bearing bars, when the length of grating > 1 meter, we will calculate as follows:

$$W1 = (t1 \times b1 \times N1 + t2 \times b2 \times N2 + 2 \times t3 \times b3) \times \rho \times \mu \times 0.000001$$

式中：

W1— 钢格板重量，单位为千克每平方米 / Grating weight, unit: kg/m²

t1— 承载扁钢宽度，单位为毫米 / Bearing bar height, unit: mm.

b1— 承载扁钢厚度，单位为毫米 / Bearing bar thickness, unit: mm.

N1— 每米钢格板中承载扁钢条数 / Nos of bearing bar per meter.

t2— 横杆宽度，单位为毫米 / Cross bar width, unit: mm.

b2— 横杆厚度，单位为毫米 / Cross bar diameter, unit: mm.

N2— 每米钢格板中横杆条数 / Nos of cross bar per meter.

t3— 包边扁钢宽度，单位为毫米 / Banding bar height, unit: mm.

b3— 包边扁钢厚度，单位为毫米 / Banding bar thickness, unit: mm.

ρ — 材料密度，单位为千克每立方米，钢材密度按 7850kg/m³ 计算 / Material density, unit: kg/m³, iron density: 7850kg/m³.

μ — 表面处理增重系数，热浸锌增重按 1.06 计算 / Surface treatment weight gain ratio, Hot Dip Galvanized weight gain is 1.06.

钢格板面积计算 / Area of Steel Grating

1. 在没有图纸，按用户提供的尺寸加工，面积为实际交付钢格板数量乘以长度和宽度的总和，它包含开孔和切口部分。
2. 提供图纸代为用户进行钢格板平面布置设计的，面积按图纸上总的外围尺寸计算，它包含开孔和切口部分。
3. 对于异型钢格板，面积按全部块数的长(L)×宽(W)计算，不扣除切口部分。几种典型示例见图。

1. For customized specifications without drawing, the square of steel gratings is calculated as per the delivered length and width plus quantities, including the opening and cutting parts.
2. For steel gratings with designed drawing for customers, the square is calculated as per drawings, including the opening and cutting parts.
3. For tailored special shaped steel gratings, the square is calculated as per the max. outer dimensions in length and width plus quantities. Followings are some typical examples:

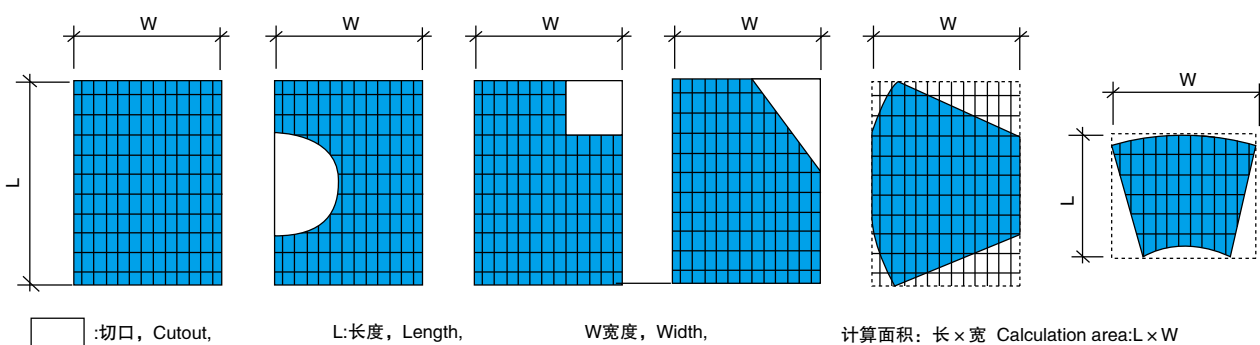

广泛应用的钢格板 Application

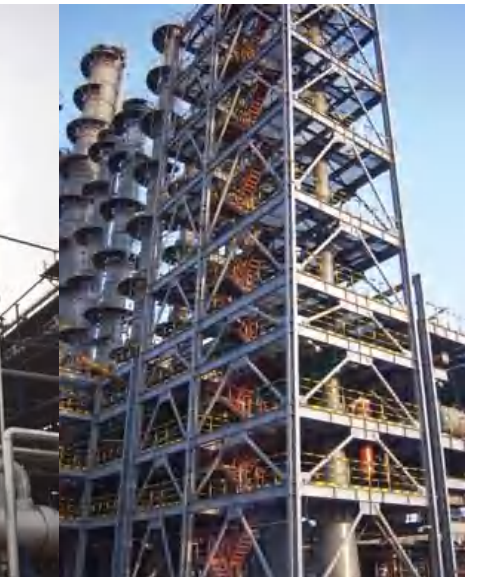

广泛应用的钢格板 Application

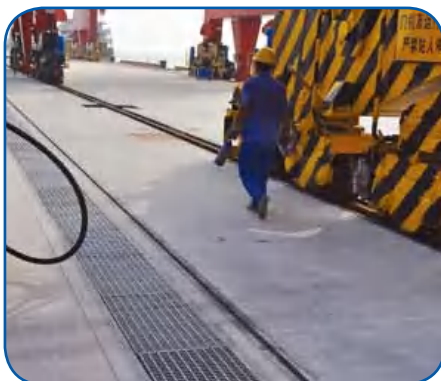
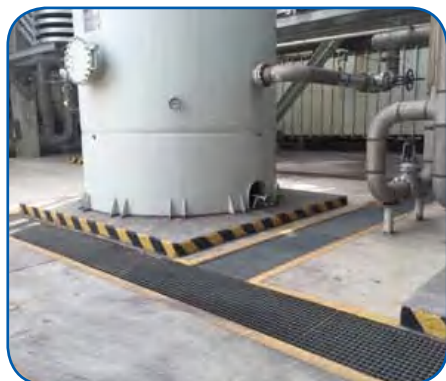

异型钢格板 Grating Tailored

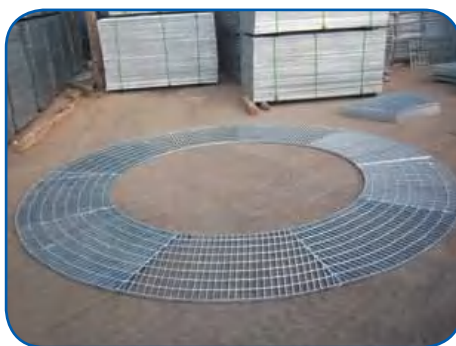
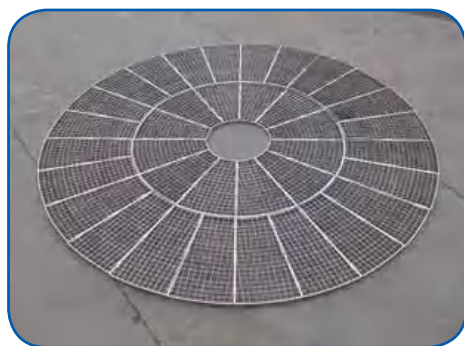

注：可按客户需求生产制作各种型号的钢格板产品。

Not: Any customized steel grating products could be produced based on customers' requirements, drawing.

重载荷压焊钢格板常用规格及安全荷载表

Common Specification and Safe Load Table for Heavy Duty Steel Gratings

型号 Type	扁钢 宽度 mm bearing bar Width	扁钢厚度 mm bearing bar thickness	横杆 尺寸 mm Cross bar size	理论 重量 kg/m ² Theory weight	荷载及 挠度 Load and deflection	跨距 mm Clear span														
						200	400	600	800	1000	1200	1400	1600	1800	2000	2200	2400	2600	2800	3000
G1508/40/100	150	8	8 × 8	284.9	U	25500	6375	2833	1593	1020	708	520	398	314	255	210	177	150	130	113
					D	0.05	0.18	0.41	0.73	1.15	1.66	2.26	2.95	3.74	4.63	5.6	6.7	7.85	9.17	10.54
G1308/40/100	130	8	8 × 8	247.6	U	19153	4788	2128	1197	766	532	390	299	236	191	158	133	113	97	85
					D	0.05	0.21	0.48	0.85	1.33	1.91	2.6	3.14	4.32	5.34	6.49	7.76	9.11	10.55	12.22
G1208/40/100	120	8	8 × 8	229.0	U	16320	4080	1813	1020	653	453	333	255	201	163	134	113	96	83	72
					D	0.06	0.23	0.52	0.92	1.44	2.07	2.83	3.7	4.68	5.8	7	8.39	9.85	11.5	13.2
G1008/40/100	100	8	8 × 8	191.7	U	11333	2833	1259	708	453	314	231	177	139	113	93	78	67	57	50
					D	0.07	0.28	0.62	1.1	1.73	2.48	3.39	4.45	5.61	6.97	8.43	10.05	11.94	13.73	15.94
G908/40/100	90	8	8 × 8	173.1	U	9180	2295	1020	573	367	255	187	143	113	91	75	63	54	46	40
					D	0.08	0.31	0.69	1.22	1.92	2.77	3.77	4.93	6.26	7.72	9.35	11.17	13.24	15.25	17.57
G808/40/100	80	8	8 × 8	154.4	U	7253	1813	805	453	290	201	148	113	89	72	59	50	42	37	32
					D	0.09	0.34	0.77	1.38	2.16	3.11	4.25	5.56	7.04	8.71	10.5	12.66	14.73	17.53	20.11
G758/40/100	75	8	8 × 8	145.1	U	6375	1593	708	398	255	177	130	99	78	63	52	44	37	32	28
					D	0.09	0.37	0.83	1.47	2.31	3.33	4.54	5.92	7.5	9.27	11.25	13.55	15.78	18.47	21.42
G756/30/100	75	6	8 × 8	140.1	U	6375	1593	708	398	255	177	130	99	78	63	52	44	37	32	28
					D	0.09	0.37	0.83	1.47	2.3	3.33	4.54	5.91	7.49	9.26	11.24	13.53	15.76	18.44	21.39
G756/40/100	75	6	8 × 8	110.1	U	4781	1195	531	298	191	132	97	74	59	47	39	33	28	24	21
					D	0.09	0.37	0.83	1.47	2.3	3.31	4.52	5.9	7.56	9.22	11.25	13.55	15.93	18.48	21.44
G706/30/100	70	6	8 × 8	131.1	U	5553	1388	617	347	222	154	113	86	68	55	45	38	32	28	24
					D	0.1	0.39	0.89	1.58	2.47	3.56	4.85	6.32	8.04	9.96	11.99	14.41	16.82	19.9	22.65
G706/40/100	70	6	8 × 8	103.2	U	4165	1041	462	260	166	115	85	65	51	41	34	28	24	21	18
					D	0.1	0.39	0.88	1.58	2.46	3.55	4.87	6.38	8.05	9.91	12.09	14.19	16.85	19.95	22.7

说明:

1. U 表示钢格板安全外加均布荷载数, KN/m²。
2. D 表示钢格板在所列安全外加载荷作用下的最大挠度。
3. 理论重量表示热镀锌钢格板长度为 1m 时的重量。

Notes:

1. U : safe and uniformly distributed load, KN/m².
2. D : the maximum deflection corresponding to the listed safe load.
3. Theoretical weight is the weight of 1m length of hot dip galvanized grating.

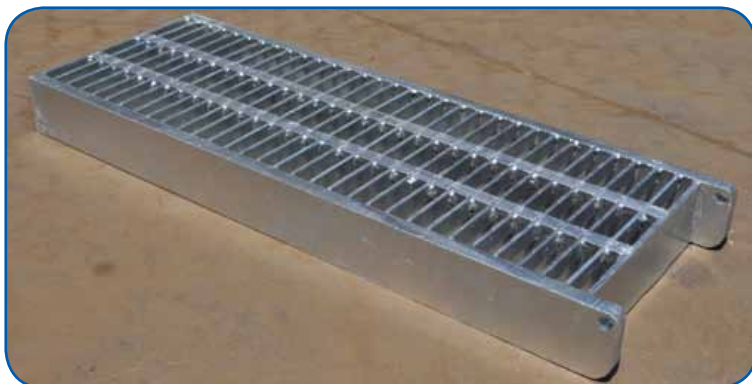

平面型扁钢中心间距为 30mm 压焊钢格板常用型号及安全荷载表
Table of Safe Load & General Type of Steel Grating With Bearing Bar Pitch at 30mm

型号 Type	扁钢宽度 mm Width of bearing bar	扁钢厚度 mm Thickness of bearing bar	理论重量 kg/m ² Theory Weight	荷载及挠度 Load and deflection	跨距 (mm) Clear Span														
					200	400	600	800	1000	1200	1400	1600	1800	2000	2200	2400	2600	2800	3000
G655/30/50	65	5	103.4	U	3990	997	443	249	159	110	81	62	49	39	32	27	23	20	17
G655/30/100			100.4	D	0.11	0.42	0.95	1.7	2.65	3.81	5.22	6.84	8.7	10.61	12.82	15.4	18.18	21.4	24.18
G605/30/50	60	5	95.9	U	3400	850	377	212	136	94	69	53	41	34	28	23	20	17	
G605/30/100			92.9	D	0.11	0.46	1.03	1.84	2.89	4.15	5.66	7.45	9.28	11.78	14.28	16.73	20.16	23.23	
G555/30/50	55	5	88.4	U	2856	714	317	178	114	79	58	44	35	28	23	19	16		
G555/30/100			85.4	D	0.13	0.5	1.13	2	3.14	4.53	6.19	8.04	10.3	12.63	15.29	18.03	21.08		
G505/30/50	50	5	80.9	U	2361	590	262	147	94	65	48	36	29	23	19	16			
G505/30/100			77.9	D	0.14	0.55	1.24	2.2	3.45	4.97	6.82	8.78	11.39	13.86	16.88	20.28			
G503/30/50	50	3	52.6	U	1416	354	157	88	56	39	28	22	17	14	11				
G503/30/100			49.6	D	0.14	0.55	1.24	2.2	3.43	4.97	6.65	8.95	11.16	14.09	16.37				
G455/30/50	45	5	73.4	U	1912	478	212	119	76	53	39	29	23	19	15				
G455/30/100			70.4	D	0.15	0.61	1.38	2.45	3.83	5.56	7.62	9.73	12.44	15.76	18.39				
G405/30/50	40	5	65.9	U	1511	377	167	94	60	41	30	23	18	15					
G405/30/100			62.9	D	0.17	0.69	1.54	2.76	4.31	6.14	8.37	11.02	13.92	17.8					
G403/30/50	40	3	43.3	U	906	226	100	56	36	25	18	14	11						
G403/30/100			40.3	D	0.17	0.69	1.54	2.74	4.32	6.25	8.39	11.2	14.21						
G355/30/50	35	5	58.4	U	1156	289	128	72	46	32	23	18	14						
G355/30/100			55.4	D	0.2	0.79	1.77	3.16	4.94	7.17	9.61	12.92	16.24						
G353/30/50	35	3	38.6	U	694	173	77	43	27	19	14	10							
G353/30/100			35.6	D	0.2	0.79	1.77	3.14	4.84	7.11	9.77	12.03							
G325/30/50	32	5	53.9	U	967	241	107	60	38	26	19	15	11						
G325/30/100			50.9	D	0.22	0.86	1.94	3.44	5.35	7.64	10.42	14.13	16.81						
G323/30/50	32	3	35.8	U	580	145	64	36	23	16	11	9							
G323/30/100			32.8	D	0.21	0.86	1.93	3.45	5.41	7.85	10.09	14.19							
G255/30/50	25	5	43.4	U	590	147	65	36	23	16	12								
G255/30/100			40.4	D	0.28	1.1	2.47	4.35	6.82	9.92	13.9								
G253/30/50	25	3	29.3	U	354	88	39	22	14	9									
G253/30/100			26.3	D	0.28	1.1	2.47	4.43	6.94	9.35									
G205/30/50	20	5	36.0	U	377	94	41	23	15	10									
G205/30/100			33.0	D	0.34	1.37	3.05	5.44	8.73	12.21									
G203/30/50	20	3	24.6	U	226	56	25	14	9										
G203/30/100			21.6	D	0.34	1.37	3.1	5.53	8.76										

★ 单人通行的走道板其均布荷载不小于 3.0KN/m²
The even load walkway plate for a single person should be over 3.0KN/m²

★ 双向通行的走道板其均布荷载不小于 5.0KN/m²
The even load walkway plate for a double-direction should be over 5.0KN/m²

★ 高密度人行走道板其均布荷载不小于 7.5KN/m²
The even load walkway plate for many people should be over 7.5KN/m²

平面型扁钢中心间距为 40mm 压焊钢格板常用型号及安全荷载表
Table of Safe Load & General Type of Steel Grating With Bearing Bar Pitch at 40mm

型号 Type	扁钢宽度 mm Width of bearing bar	扁钢厚度 mm Thickness of bearing bar	理论重量 kg/m ² Theory Weight	荷载及 挠度 Load and deflection	跨距 (mm) Clear Span														
					200	400	600	800	1000	1200	1400	1600	1800	2000	2200	2400	2600	2800	3000
G655/40/50	65	5	81.7	U	2992	748	332	187	119	83	61	46	36	29	24	20	17	15	
G655/40/100			78.7	D	0.11	0.42	0.95	1.7	2.65	3.84	3.93	6.78	8.54	10.54	12.84	15.25	17.97	21.46	
G605/40/50	60	5	75.9	U	2550	637	283	159	102	70	52	39	31	25	21	17	15		
G605/40/100			72.9	D	0.11	0.46	1.03	1.84	2.89	4.12	4.27	7.32	9.36	11.57	14.31	16.54	20.21		
G555/40/50	55	5	70.1	U	2142	535	238	133	85	59	43	33	26	21	17	14			
G555/40/100			67.1	D	0.13	0.5	1.13	2	3.13	4.51	4.59	8.05	10.22	12.66	15.11	17.77			
G505/40/50	50	5	64.2	U	1770	442	196	110	70	49	36	27	21	17	14				
G505/40/100			61.2	D	0.14	0.55	1.24	2.2	3.43	5	5.12	8.79	11.02	13.69	16.64				
G503/40/50	50	3	42.6	U	1062	265	118	66	42	29	21	16	13	10					
G503/40/100			39.6	D	0.14	0.55	1.24	2.2	3.43	4.94	4.99	8.71	11.4	13.49					
G455/40/50	45	5	58.4	U	1434	358	159	89	57	39	29	22	17	14					
G455/40/100			55.4	D	0.15	0.61	1.38	2.44	3.83	5.46	5.67	9.85	12.28	15.53					
G405/40/50	40	5	52.6	U	1133	283	125	70	45	31	23	17	13	11					
G405/40/100			49.6	D	0.17	0.69	1.54	2.74	4.32	6.2	6.42	10.88	13.45	17.47					
G403/40/50	40	3	35.3	U	680	170	75	42	27	18	13	10	8						
G403/40/100			32.3	D	0.17	0.69	1.54	2.74	4.32	6.01	6.08	10.71	13.84						
G355/40/50	35	5	46.8	U	867	216	96	54	34	24	17	13	10						
G355/40/100			43.8	D	0.2	0.78	1.77	3.16	4.88	7.18	7.12	12.48	15.54						
G353/40/50	35	3	31.6	U	520	130	57	32	20	14	10	8							
G353/40/100			28.6	D	0.2	0.79	1.75	3.12	4.79	7	7.01	12.85							
G325/40/50	32	5	43.3	U	725	181	80	45	29	20	14	11							
G325/40/100			40.3	D	0.21	0.86	1.93	3.45	5.45	7.84	7.7	13.86							
G323/40/50	32	3	29.4	U	435	108	48	27	17	12	8								
G323/40/100			26.4	D	0.21	0.86	1.93	3.45	5.34	7.86	7.37								
G255/40/50	25	5	35.1	U	442	110	49	27	17	12	9								
G255/40/100			32.1	D	0.27	1.1	2.48	4.35	6.74	9.94	10.46								
G253/40/50	25	3	24.3	U	265	66	29	16	10	7									
G253/40/100			21.3	D	0.27	1.1	2.45	4.3	6.63	9.71									
G205/40/50	20	5	29.3	U	283	70	31	17	11	7									
G205/40/100			26.3	D	0.34	1.36	3.08	5.37	8.56	11.46									
G203/40/50	20	3	20.6	U	170	42	18	10	6										
G203/40/100			17.6	D	0.34	1.37	2.98	5.28	7.84										

说明:

1. U 表示钢格板安全外加均布荷载数, KN/m²。
2. D 表示钢格板在所列安全外加荷载作用下的最大挠度。
3. 理论重量表示热镀锌钢格板长度为 1m 时的重量。

Notes:

1. U : safe and uniformly distributed load, KN/m².
2. D : the maximum deflection corresponding to the listed safe load.
3. Theoretical weight is the weight of 1m length of hot dip galvanized grating.

平面型扁钢中心间距 60mm 压焊钢格板常用规格及安全荷载表
Common Specification and Safe Load Table of Steel Grating
(Plain Style, Bearing Bars at 60mm Pitch)

型号 Type	扁钢 尺寸 mm bearing bar section	横杆 间距 mm Cross bar pitch	理论 重量 kg/m ² Theory weight	齿型系数 Serration factor		荷载及 挠度 Load and deflection	跨距 mm Clear Span															
				载荷 Load	挠度 Deflection		150	300	450	600	750	900	1050	1200	1500	1800	2100	2400	2700	3000	3300	3600
G655/60/50	65 × 5	50	49.0	0.92	1.04	U	3436.41	858.79	381.42	214.34	137.01	95.00	69.67	53.23	33.89	23.39	17.06	12.95	10.13	8.12	6.62	5.49
						D	0.06	0.24	0.55	0.99	1.54	2.22	3.03	3.96	6.18	8.91	12.12	15.84	20.02	24.75	29.94	35.64
G555/60/50	55 × 5	50	42.4	0.90	1.05	U	2460.46	614.80	273.02	153.99	98.02	67.94	49.81	38.04	24.20	16.68	12.14	9.20	7.18	5.47	4.67	3.86
						D	0.07	0.29	0.65	1.17	1.82	2.63	3.58	4.68	7.31	10.53	14.33	18.72	23.69	29.25	35.39	42.12
G505/60/50	50 × 5	50	39.0	0.89	1.06	U	2033.40	508.06	225.60	126.73	80.97	56.11	41.13	31.40	19.96	13.74	10.00	7.56	5.90	4.70	3.82	
						D	0.08	0.32	0.72	1.28	2.01	2.89	3.94	5.14	8.04	11.58	15.76	28.59	26.06	32.17	38.93	
G455/60/50	45 × 5	50	35.7	0.88	1.07	U	1647.01	411.49	182.69	102.61	65.54	45.41	33.27	25.39	16.12	11.09	8.06	6.09	4.73	3.77	3.05	
						D	0.08	0.35	0.80	1.43	2.23	3.21	4.37	5.72	8.93	12.87	17.51	22.88	28.95	35.75	43.25	
G405/60/50	40 × 5	50	32.3	0.87	1.07	U	1301.30	325.09	144.31	81.03	51.75	35.84	26.25	20.02	12.70	8.72	6.32	4.77	3.70	2.94		
						D	0.10	0.40	0.90	1.60	2.51	3.62	4.92	6.43	10.05	14.47	19.70	25.74	32.57	40.12		
G403/60/50	40 × 3	50	21.7	0.87	1.07	U	780.76	195.3	86.56	48.60	31.02	21.48	15.72	11.99	7.60	5.21	3.77	2.84	2.20	1.74		
						D	0.10	0.40	0.90	1.60	2.51	3.62	4.92	6.43	10.05	14.47	19.70	25.74	32.57	40.21		
G325/60/50	32 × 5	50	27.0	0.83	1.09	U	832.77	207.99	92.29	51.80	33.06	22.87	16.74	12.75	8.06	5.52	3.98	2.99	2.31			
						D	0.12	0.50	1.13	2.01	3.14	4.52	6.15	8.04	12.56	18.09	24.63	32.17	40.72			
G323/60/50	32 × 5	50	18.5	0.83	1.09	U	499.64	124.77	55.35	31.06	19.81	13.70	10.02	7.63	4.81	3.29	2.37	1.77	1.36			
						D	0.12	0.50	1.13	2.01	3.14	4.52	6.15	8.04	12.56	18.09	24.63	32.17	40.72			
G255/60/50	25 × 5	50	22.3	0.79	1.12	U	508.22	126.89	56.27	31.56	20.12	13.90	10.16	7.72	4.86	3.31	2.37	1.77				
						D	0.16	0.54	1.44	2.57	4.02	5.79	7.88	10.29	16.08	23.16	31.55	41.18				
G253/60/50	25 × 3	50	15.7	0.79	1.12	U	304.91	76.15	33.74	18.91	12.05	8.32	6.07	4.61	2.89	1.96	1.40	1.04				
						D	0.16	0.64	1.44	2.57	4.02	5.79	7.88	10.29	16.08	23.16	31.53	41.18				
G205/60/50	20 × 5	50	19.0			U	325.22	81.16	35.97	20.15	12.83	8.85	6.45	4.90	3.07	2.07	1.47					
						D	0.20	0.80	1.81	3.21	5.02	7.23	9.85	12.87	20.10	28.95	39.41					

说明:

1. U 表示钢格板安全外加均布荷载数, KN/m²。
2. D 表示钢格板在所列安全外加荷载作用下的最大挠度。
3. 理论重量表示热镀锌钢格板长度为 1m 时的重量。

Notes:

1. U : safe and uniformly distributed load, KN/m².
2. D : the maximum deflection corresponding to the listed safe load.
3. Theoretical weight is the weight of 1m length of hot dip galvanized grating.

常用钢格板选型指南

Common Steel Grating Selection Guide

表一

承载扁钢尺寸 Bearing Bar Size	检修平台 Maintenance Platform			行人较少的平台 Fewer Pedestrians Platform			行人密集的平台 Pedestrian Density Platform		
	均布载荷 =2.5KN/m ² Even Load=2.5KN/m ² 挠度 5mm Deflection 5mm			均布载荷 =3KN/m ² Even Load=3KN/m ² 挠度 5mm Deflection 5mm			均布载荷 =4KN/m ² Even Load=4KN/m ² 挠度 5mm Deflection 5mm		
	承载扁钢中心距 Bearing Bar Pitch			承载扁钢中心距 Bearing Bar Pitch			承载扁钢中心距 Bearing Bar Pitch		
	30mm	40mm	60mm	30mm	40mm	60mm	30mm	40mm	60mm
32 × 3	1700	1580	1430	1620	1510	1360	1510	1400	1270
40 × 3	2010	1870	1690	1920	1780	1610	1780	1660	1500
25 × 5	1600	1490	1350	1530	1420	1290	1420	1320	1200
32 × 5	1930	1790	1620	1840	1710	1550	1710	1590	1440
40 × 5	2280	2120	1920	2180	2030	1830	2030	1890	1700

表二

承载扁钢尺寸 Bearing Bar Size	一般工厂手推车通行 Usually Factory Trolley Passage						均布载荷 =7.5KN/m ² Even Load=7.5KN/m ²					
	均布载荷 =5KN/m ² Even Load=5KN/m ²											
	挠度 =5mm Deflection 5mm			挠度 =10mm Deflection 10mm			挠度 =5mm Deflection 5mm			挠度 =10mm Deflection 10mm		
	承载扁钢中心距 Bearing Bar Pitch			承载扁钢中心距 Bearing Bar Pitch			承载扁钢中心距 Bearing Bar Pitch			承载扁钢中心距 Bearing Bar Pitch		
	30mm	40mm	60mm	30mm	40mm	60mm	30mm	40mm	60mm	30mm	40mm	60mm
25 × 5	1350	1250	1130	1600	1490	1530	1220	1130	1020	1450	1350	1220
32 × 5	1620	1510	1360	1930	1790	1620	1460	1360	1230	1740	1620	1460
40 × 5	1920	1780	1610	2280	2120	1920	1730	1610	1460	2060	1920	1730
45 × 5	2090	1950	1760	2490	2320	2090	1890	1760	1590	2250	2090	1890
50 × 5	2270	2110	1910	2700	2510	2270	2050	1910	1720	2440	2270	2050
55 × 5	2440	2270	2050	2900	2700	2440	2200	2050	1850	2620	2440	2200
65 × 5	2760	2570	2320	3290	3060	2760	2490	2320	2100	2970	2760	2490
75 × 5	3080	2860	2590	3660	3400	3080	2780	2590	2340	3300	3080	2780
75 × 6	3220	3000	2710	3830	3560	3220	2910	2710	2440	3460	3220	2910

★ 单人通行的走道板其均布载荷不小于 3.0KN/m²
The even load walkway plate for a single person should be over 3.0KN/m²

★ 双向通行的走道板其均布载荷不小于 5.0KN/m²
The even load walkway plate for a double-direction should be over 5.0KN/m²

★ 高密度人行走道板其均布载荷不小于 7.5KN/m²
The even load walkway plate for many people should be over 7.5KN/m²

I 型钢中心间距为 30mm 压焊钢格板常用规格及安全荷载表
Common Specification and Safe Load Table of Steel Grating
(I Style, Bearing Bars at 30mm Pitch)

型号 Type	型钢 宽度 mm Beam width	翼缘 厚度 mm Flange thickness	腹部 厚度 mm Abdominal thickness	翼缘 宽度 mm Flange width	理论 重量 kg/m ² Theory weight	荷载及 挠度 Load and deflection	跨距 mm Clear Span														
							200	400	600	800	1000	1200	1400	1600	1800	2000	2200	2400	2600	2800	3000
G757/30/50 I	75	7	4	12	126.1	U	6460	1615	717	403	258	179	131	100	79	64	53	44	38	32	28
G757/30/100 I					120.7	D	0.09	0.37	0.83	1.47	2.3	3.31	4.5	5.88	7.47	9.25	11.26	13.3	15.89	18.11	20.99
G657/30/50 I	65	7	4	10	110.1	U	4862	1215	540	303	194	135	99	75	60	48	40	33	28	24	21
G657/30/100 I					104.8	D	0.11	0.42	0.95	1.69	2.65	3.83	5.22	6.77	8.71	10.67	13.07	15.36	18.05	20.94	24.29
G607/30/50 I	60	7	4	10	99.1	U	4216	1054	468	263	168	117	86	65	52	42	34	29	24	21	18
G607/30/100 I					96.1	D	0.11	0.46	1.03	1.83	2.86	4.13	5.65	7.31	9.4	11.62	13.85	16.81	19.29	22.82	25.97
G557/30/50 I	55	7	4	8.5	90.3	U	3502	875	389	218	140	97	71	54	43	35	28	24	20	17	
G557/30/100 I					87.3	D	0.13	0.5	1.13	2	3.15	4.53	6.17	8.03	10.29	12.82	15.11	18.44	21.32	24.55	
G507/30/50 I	50	7	4	8	83.2	U	2912	728	323	182	116	80	59	45	35	29	24	20	17		
G507/30/100 I					80.2	D	0.14	0.55	1.24	2.21	3.44	4.94	6.78	8.85	11.09	14.09	17.14	20.37	24.01		
G505/30/50 I	50	5	3	8.5	62.8	U	2085	521	231	130	83	57	42	32	25	20	17	14			
G505/30/100 I					59.8	D	0.14	0.55	1.23	2.2	3.44	4.91	6.73	8.79	11.06	13.57	16.97	19.95			
G445/30/50 I	44	5	3	8	56.5	U	1654	413	183	103	66	45	33	25	20	16	13				
G445/30/100 I					53.5	D	0.16	0.62	1.4	2.5	3.92	5.56	7.59	9.86	12.71	15.6	18.7				
G385/30/50 I	38	5	3	7	49.9	U	1246	311	138	77	49	34	25	19	15	12					
G385/30/100 I					46.9	D	0.18	0.73	1.64	2.89	4.51	6.52	8.93	11.64	14.82	18.22					
G325/30/50 I	32	5	3	6	43.3	U	884	221	98	55	35	24	18	13	10						
G325/30/100 I					40.3	D	0.21	0.86	1.94	3.44	5.37	7.68	10.74	13.35	16.6						
G255/30/50 I	25	5	3	4.5	35.1	U	544	136	60	34	21	15	11								
G255/30/100 I					32.1	D	0.28	1.1	2.47	4.45	6.75	10.06	13.77								

★ 单人通行的走道板其均布荷载不小于 3.0KN/m²
 The even load walkway plate for a single person should be over 3.0KN/m²

★ 双向通行的走道板其均布荷载不小于 5.0KN/m²
 The even load walkway plate for a double-direction should be over 5.0KN/m²

★ 高密度人行走道板其均布荷载不小于 7.5KN/m²
 The even load walkway plate for many people should be over 7.5KN/m²

I 型钢中心间距为 40mm 压焊钢格板常用规格及安全荷载表
Common Specification and Safe Load Table of Steel Grating
(I Style, Bearing Bars at 40mm Pitch)

型号 Type	型钢 宽度 mm Beam width	翼缘 厚度 mm Flange thickness	腹部 厚度 mm Abdominal thickness	翼缘 宽度 mm Flange width	理论 重量 kg/m ² Theory weight	荷载及 挠度 Load and deflection	跨距 mm Clear Span														
							200	400	600	800	1000	1200	1400	1600	1800	2000	2200	2400	2600	2800	3000
G757/40/50 I	75	7	4	12	101	U	4845	1211	538	302	193	134	98	75	75	59	48	40	33	28	24
G757/40/100 I					95.6	D	0.09	0.37	0.83	1.47	2.29	3.31	4.49	5.89	5.89	7.44	9.27	11.35	13.33	15.66	18.16
G657/40/50 I	65	7	4	10	88.5	U	3646	911	405	227	145	101	74	56	56	45	36	30	25	21	18
G657/40/100 I					83.2	D	0.11	0.42	0.95	1.69	2.64	3.83	5.21	6.75	6.75	8.72	10.68	13.1	15.54	18.1	21
G607/40/50 I	60	7	4	10	78.9	U	3162	790	351	197	126	87	64	49	49	39	31	26	21	18	16
G607/40/100 I					75.9	D	0.11	0.46	1.03	1.83	2.86	4.1	5.61	7.35	7.35	9.41	11.46	14.13	16.28	19.33	23.23
G557/40/50 I	55	7	4	8.5	71.9	U	2626	656	291	164	105	72	53	41	41	32	26	21	18	15	
G557/40/100 I					68.9	D	0.13	0.5	1.13	2.01	3.15	4.49	6.14	8.14	8.14	10.22	12.72	15.14	18.48	21.37	
G507/40/50 I	50	7	4	8	66.4	U	2184	546	242	136	87	60	44	34	34	26	21	18	15		
G507/40/100 I					63.4	D	0.14	0.55	1.24	2.2	3.45	4.95	6.74	8.93	8.93	11	13.62	17.18	20.42		
G505/40/50 I	50	5	3	8.5	50.4	U	1564	391	173	97	62	43	31	24	24	19	15	12			
G505/40/100 I					47.4	D	0.14	0.55	1.23	2.19	3.43	4.95	6.64	8.8	8.8	11.22	13.6	16.05			
G445/40/50 I	44	5	3	8	45.5	U	1241	310	137	77	49	34	25	19	19	15	12				
G445/40/100 I					42.5	D	0.16	0.62	1.4	2.49	3.88	5.61	7.68	10.01	10.01	12.73	15.64				
G385/40/50 I	38	5	3	7	40.3	U	935	233	103	58	37	25	19	14	14	11					
G385/40/100 I					37.3	D	0.18	0.73	1.63	2.91	4.55	6.4	9.06	11.47	11.47	14.54					
G325/40/50 I	32	5	3	6	35.1	U	663	165	73	41	26	18	13	10	10						
G325/40/100 I					32.1	D	0.21	0.86	1.92	3.43	5.33	7.69	10.37	13.71	13.71						
G255/40/50 I	25	5	3	4.5	28.7	U	408	102	45	25	16	11	8								
G255/40/100 I					25.8	D	0.28	1.1	2.47	4.36	6.86	9.86	13.41								

说明:

1. U 表示钢格板安全外加均布荷载数, KN/m²。
2. D 表示钢格板在所列安全外加荷载作用下的最大挠度。
3. 理论重量表示热镀锌钢格板长度为 1m 时的重量。

Notes:

1. U : safe and uniformly distributed load, KN/m².
2. D : the maximum deflection corresponding to the listed safe load.
4. Theoretical weight is the weight of 1m length of hot dip galvanized grating.

钢格板安装 Installation of Steel Grating

安装方法 / Installation Method

1. 钢格板的安装有焊接和安装夹两种方法。焊接固定适用于永久不需拆卸的部位，如设备周围平台，而采用安装夹具有不破坏锌层及拆卸方便的特点。
2. 焊接固定的方法是：在钢格板每个角第一根扁钢上，焊缝长不小于20mm，高不小于3mm的焊角。
3. 安装夹适用于各种系列的钢格板，由上卡、下卡和M8内六角圆柱头螺栓组成。
4. 采用安装夹固定，每块板至少采用四套安装夹，对跨距较大的板块最好在可利用的支撑物上多安装几个。

1. There are two ways of installation for grating. One is by welding and the other is by installation clips. Welding is suitable for those parts which will be fixed forever, such as platforms for equipment. Installation by clips has the properties of easy disassembling, which will cause no damage to the zinc coating.
2. How to weld: to weld at the first bearing bar of each angle. Welding seam of which is not less than 20mm in length and less than 3mm in height.
3. Installation by clips is suitable for all types of gratings. It concludes the up-fastener, down-fastener and M8 hex socket bolt.
4. Four sets of clips should be fixed for one piece of grating. More will be required for larger span steel gratings.

安装间隙 / Installation Pitch

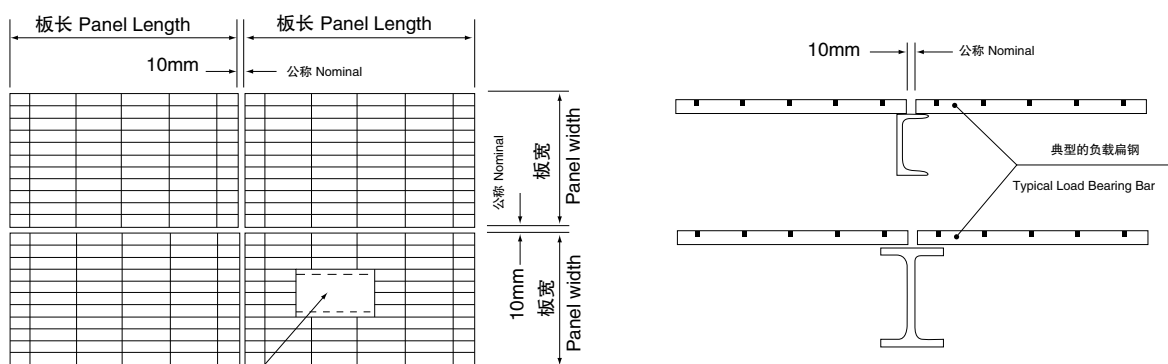

虚线为规定切除，实线为实际切除。
 矩形切口按下一根负载扁钢能让障碍物通过来制作。
 Dotted line area is the specified cutout. Real line area are made on condition that the next bearing bar can let obstruction pass.

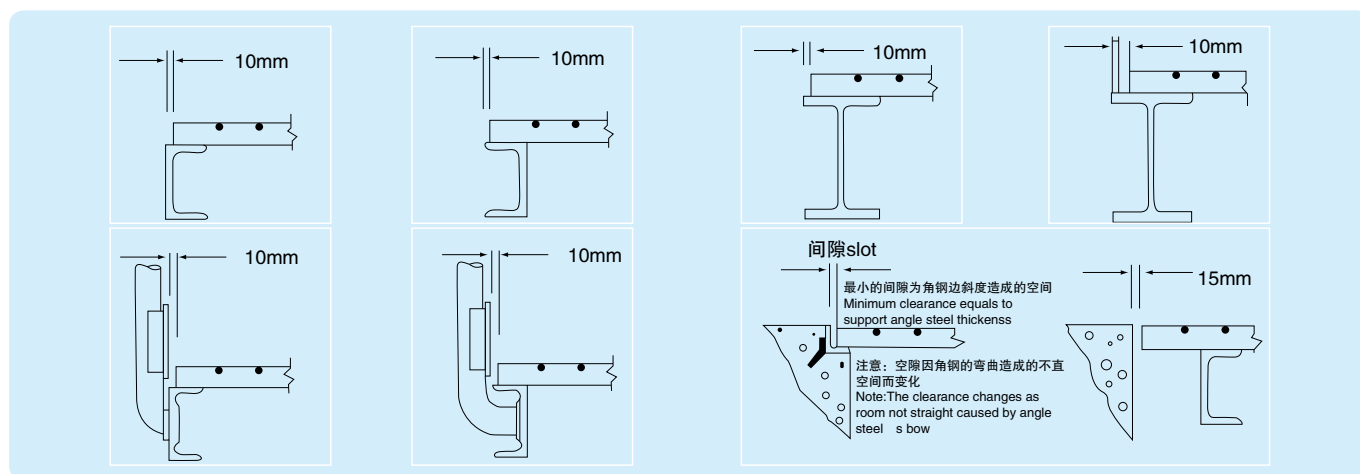

以上所示间隙，均为设计时采用。由于格栅板存在一定加工偏差，实际尺寸与设计尺寸略有不同。另外，我们采用圆形障碍物的切口比障碍物的直径大 30~50 毫米。

Clearances shown above are used when designing. The actual dimensions would vary slightly from the designing dimensions due to certain manufacturing deviations. In addition, cutouts for circular obstructions are recommended to be at least 30~50mm larger in diameter than the obstruction.

钢格板安装 Installation of Steel Grating

安装夹 / Installation Fastener

1. 为满足客户的要求，可提供不锈钢安装夹。
 2. 在订购安装夹时，请注明所需夹子的类型、数量和材料。
1. Stainless Steel clips are available.
 2. Please state clearly the clip type, quantity and material when order.

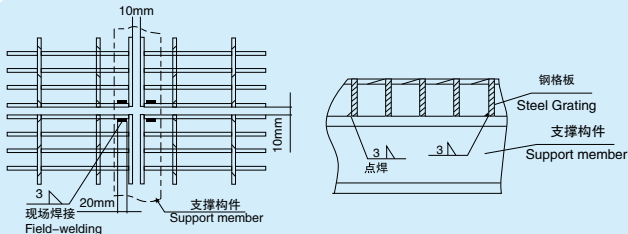

(一) 直接焊接式
I. Direct welding

注: 1、直接将钢格板点焊在支撑梁上。
2、点焊处作防腐处理。

Note: 1. Weld on the support member of the gratings
2. Anti-corrosion surface treatment is necessary for the welding points

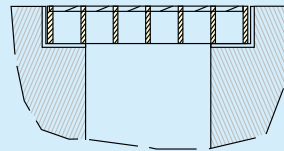

(二) 钢结构限位(多用于沟盖板)

II. Limit Positioning (commonly used for trench cover)

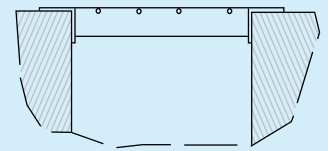

(三) A型安装夹-上下压片夹紧式
III. Type A clips

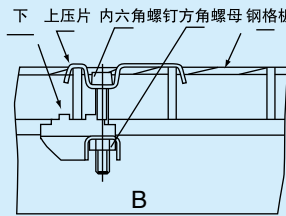

(四) B型安装夹-上下压片加长式
IV. Type B clips

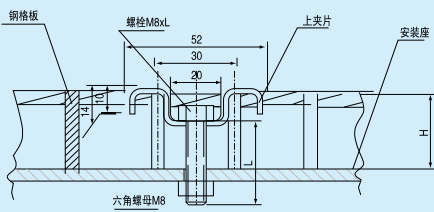
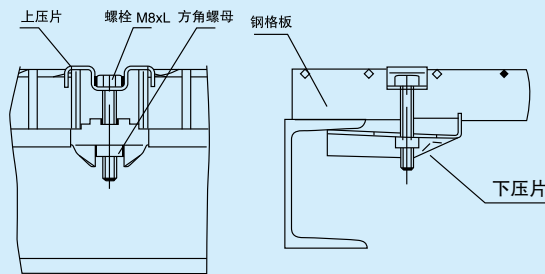
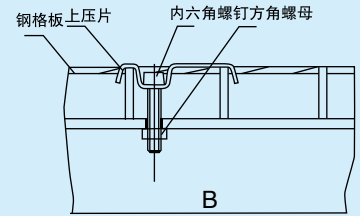

(五) C型安装夹-螺栓旋接式
V. Type C clips (Screwed)

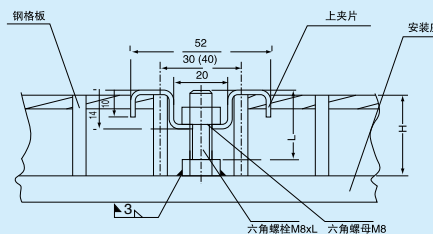

(六) D型安装夹-螺栓焊接式
VI. Type D clips (Bolt welded)

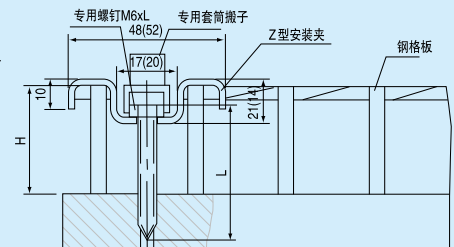

(七) Z型安装夹具-自攻螺钉式
VII. Type Z clips (Self-tread)



A型
Type A



B型
Type B



C型
Type C



钢梯 Steel Ladder

钢梯采用钢格板做梯子踏步板。产品符合国标15J401，工厂一次制作成型，安装简便。热镀锌处理，维护方便。
Steel ladder are formation shaped with steel grating treads, 15J401 standard.
It is hot dipped galvanized, easy for installation and maintenance.

型号标记 Symbol of Type

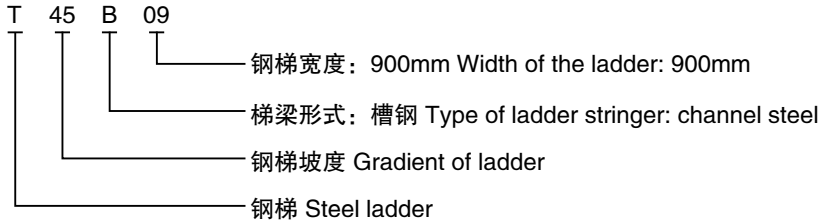

类型 Type	型号 Model No.	坡度 Gradient	宽度 Width	梯梁 Stringer Type	踏步板 Tread
斜梯 A Type A	T35.5A08	35.5°	800	-200 × 10	G255/30/100
	T35.5A10	35.5°	1000	-200 × 10	G325/30/100
	T45A06	45°	600	-180 × 10	G255/30/100
	T45A08	45°	800	-180 × 10	G255/30/100
	T45A10	45°	1000	-180 × 10	G325/30/100
	T59A06	59°	600	-150 × 8	G255/30/100
	T59A08	59°	800	-150 × 8	G255/30/100
	T73A06	73°	1000	-120 × 8	G255/30/100
斜梯 B Type B	T35.5B08	35.5°	800	C16a	G255/30/100
	T35.5B10	35.5°	1000	C16a	G325/30/100
	T45B06	45°	600	C16a	G255/30/100
	T45B08	45°	800	C16a	G255/30/100
	T45B10	45°	1000	C16a	G325/30/100
	T59B06	59°	600	C16a	G255/30/100
	T59B08	59°	800	C16a	G255/30/100
	T73B06	73°	600	C12.6	G255/30/100
斜梯 D Type D	T35.5D08	35.5°	800	C16a	G255/30/100
	T35.5D10	35.5°	1000	C16a	G325/30/100
	T45D06	45°	600	C16a	G255/30/100
	T45D08	45°	800	C16a	G255/30/100
	T45D10	45°	1000	C16a	G325/30/100
	T59D06	59°	600	C16a	G255/30/100
	T59D08	59°	800	C16a	G255/30/100
	T73D06	73°	600	C12.6	G255/30/100

- ★ 斜梯A为钢板侧梁，斜梯B及斜梯D为槽钢侧梁。斜梯D为顶端带平台。
- ★ 钢梯角度超过45度时，钢梯栏杆的立柱应与梯侧梁垂直安装。
- ★ Beam for Type A is made of steel plate; stringer for type B and type D is made of channel steel; there is a platform on top of type D ladder.
- ★ If the gradient is over 45 degree, the guardrail column should be vertically installed against the side beam.

- ★ 钢梯详细结构及尺寸见《建筑钢梯图集15J401》。
- ★ 可按《建筑钢梯图集15J401》制作直梯及带护笼直梯。
- ★ For more details, please take reference from 《Steel ladder atlas 15J401》.
- ★ Straight ladder with or without protection cage are available.

钢梯踏步板 Steel Ladders and Stair Treads

我公司生产由格栅踏步板组成的带防护栏杆的钢梯。选用时，请参阅全国通用建筑标准图15J401。格栅踏步板根据有无前护板和与梯梁的联接方式，有四种型式，表示为T1、T2、T3、T4。从经济的角度考虑，我们建议尽可能采用下列推荐的长度和宽度。Our company produces steel ladders with guardrail, which are made of grating treads. When specifying the steel ladders, please refer to the national standard construction drawing 15J401. According to whether the nosings are to be used and the methods of mounting to stringers, stair treads are classified into four types: T1, T2, T3, T4. We suggest that the dimensions are as follows.

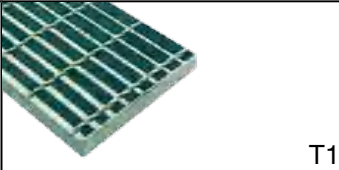
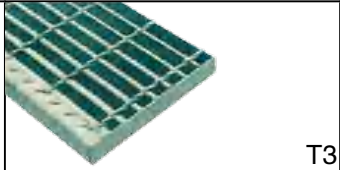
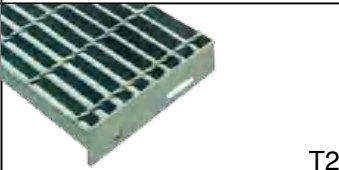
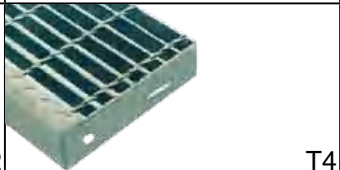
	无前护板 No nosing	花纹前护板 Checkered plate nosing	
焊接固定 Welded fixing			T1 T3
螺栓固定 Bolted fixing			T2 T4





梯踏板最大长度 / Max. Stair Tread Lengths 推荐梯踏板宽度 / Recommended Stair Tread Widths

扁钢尺寸 Bearing bar section	钢格栅规格 Steel grating specification		
	25 × 3	25 × 5	32 × 5
扁钢中心间距 30mm Bearing bars at 30mm pitch	550	900	1300
扁钢中心间距 40mm Bearing bars at 40mm pitch	450	750	1200

T1、T2、T3、T4 扁钢中心间距30mm Bearing bars at 30mm pitch	95	125	155	185	215	245	275
T1、T2、 扁钢中心间距40mm Bearing bars at 40mm pitch T3、T4、	125	165		205	245	285	
	115	155		195	235	275	
螺栓孔中心距 A (mm) Fixing hole centers	45	75	100	150			

注：扁钢厚5mm。Note: Bearing bar thickness 5mm.

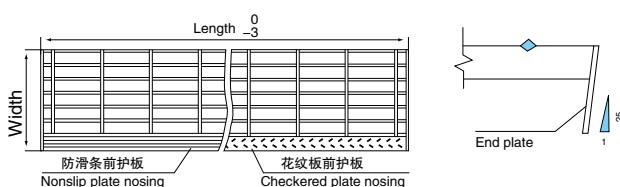
踏步板公差 / Tolerance of Stair Treads



踏步板侧板 / End Plate of Stair Treads

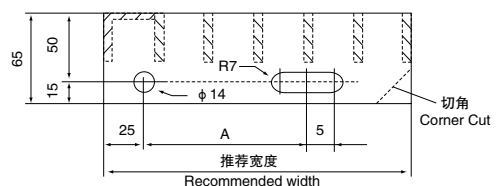

侧板用65 × 5的扁钢。仅在客户需要时才切角。
End plate is made of 65 × 5mm flat steel and corner cut only at request .

吊顶 Ceiling

采用钢格板设计制造，结构轻便，美观，高强度可行人，安装简便。表面热镀锌，防腐耐用且免油漆维护。广泛适用于烟草制造、工业厂房、大型体育馆、会展中心、大型商场、车站、码头、机场等工业及民用建筑的吊顶。

Ceilings, which are designed & produced by steel gratings, are with light structure but high strength to have people walking on. It is hot dipped galvanized, anti-corrosion and durable, paint free maintenance. It is widely used tobacco manufacturing industry, industrial plants, large gymnasium, exhibition, shopping mall, stations, yard, airport, etc.

常用吊顶钢格板选型表
common specification of ceiling grating

跨距 Span	型号 Model No.
3000 × 3000 (4000 × 4000)	G253/40/100FG
	G253/60/100FG
	G303/60/100FG
	G323/60/100FG
	G323/80/100FG
	G403/60/100FG
	G403/80/100FG

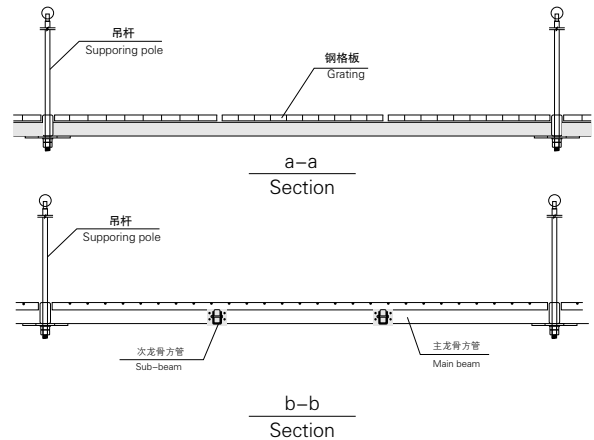
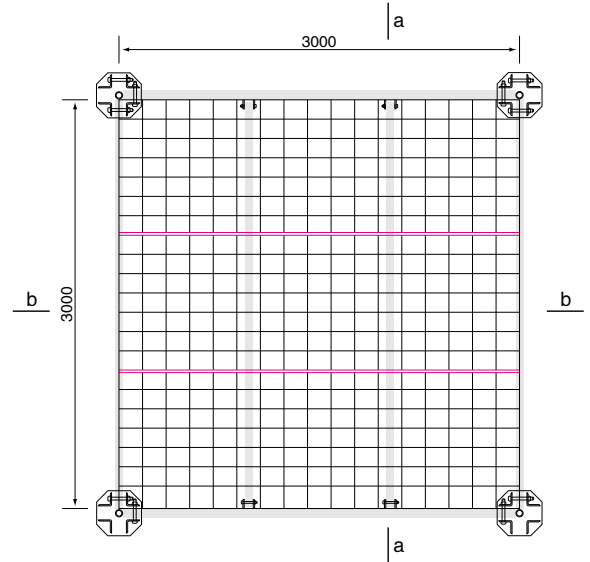

沟盖板 Trench Cover Grating

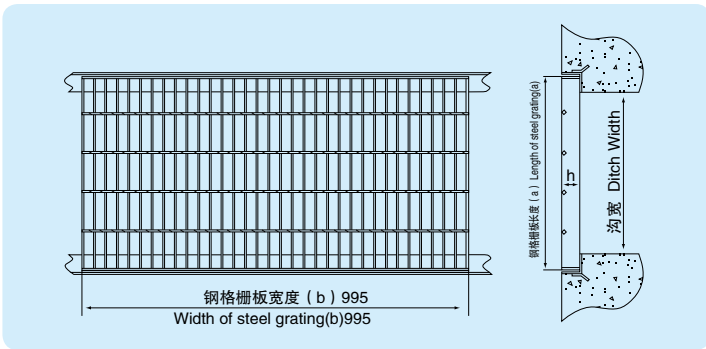
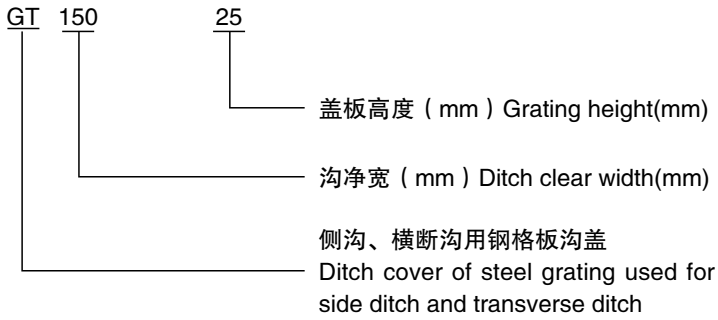

U 沟盖板 / U type –Steel Grating Ditch Cover

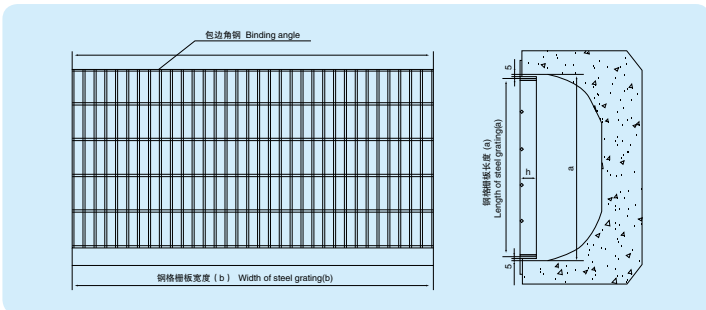
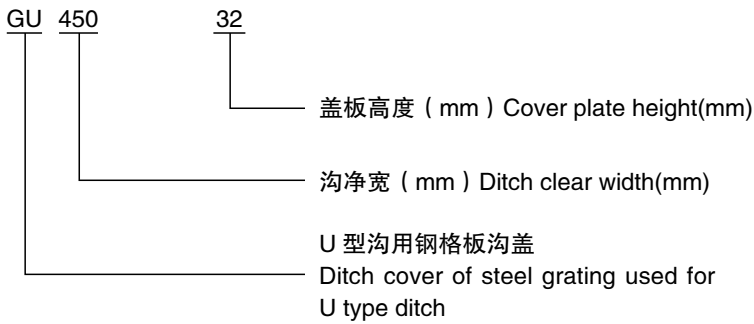

侧沟盖和横断沟盖 / Side ditch cover and transverse ditch cover

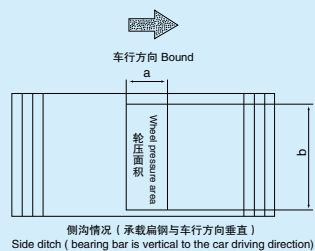
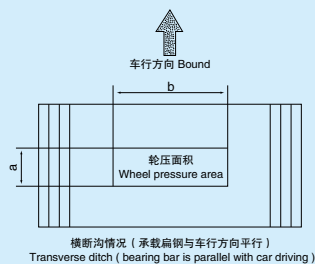

GM 型井孔钢格板盖

GM Type – Steel Grating Manhole

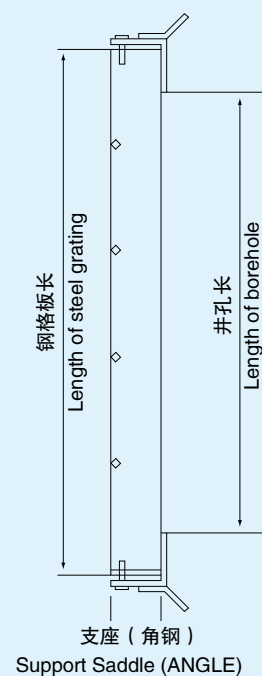
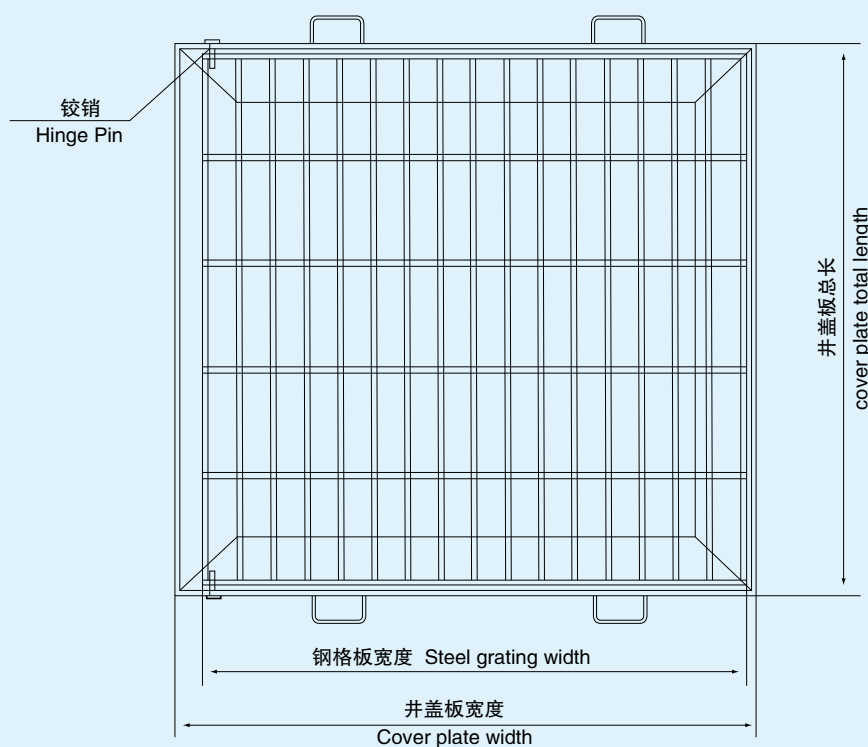
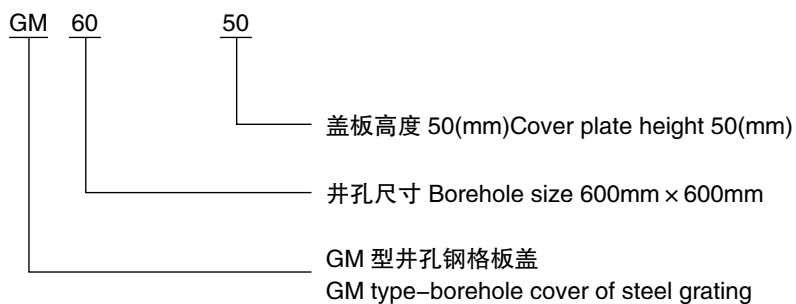
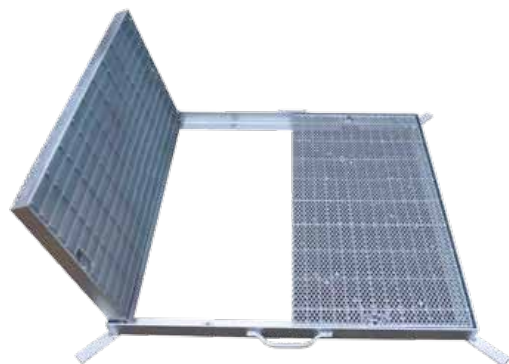

安装须知 / Installation notes

- a、井盖支撑面必须平整、坚固、与支框紧贴；
- b、锚固片必须牢固地埋入水泥或沥青层内。
- a. The support surface of borehole cover must be smooth and solid, and as close as possible to the frame.
- b. Anchors must be firmly embedded in cement or bitumen layer.



GM 型井孔钢格板盖 GM Type – Steel Grating Manhole

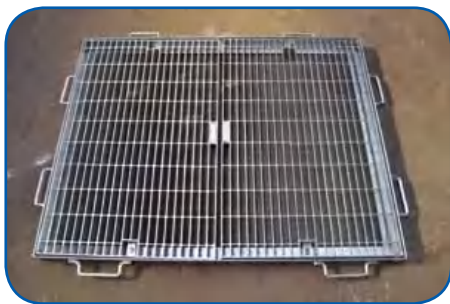
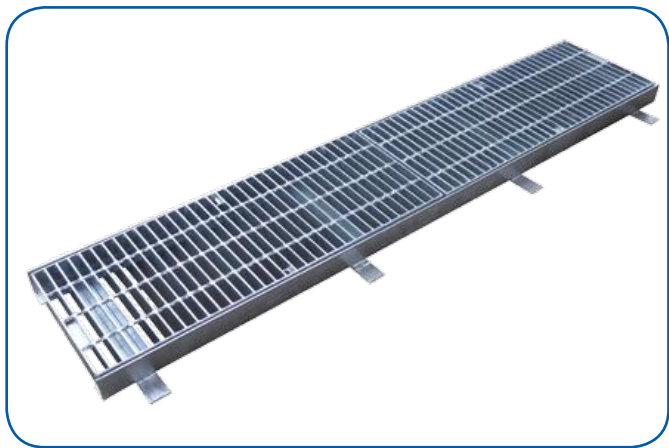
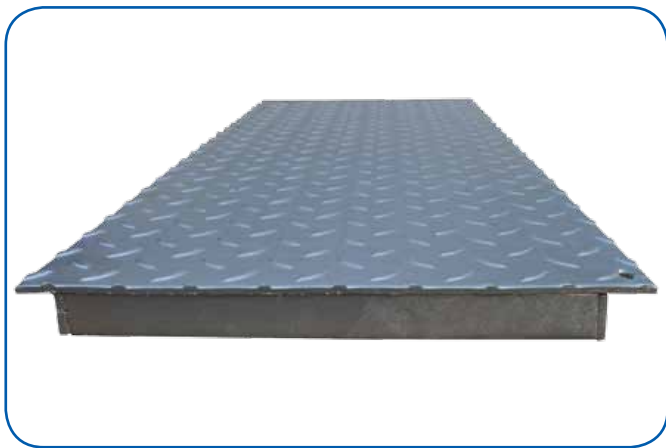
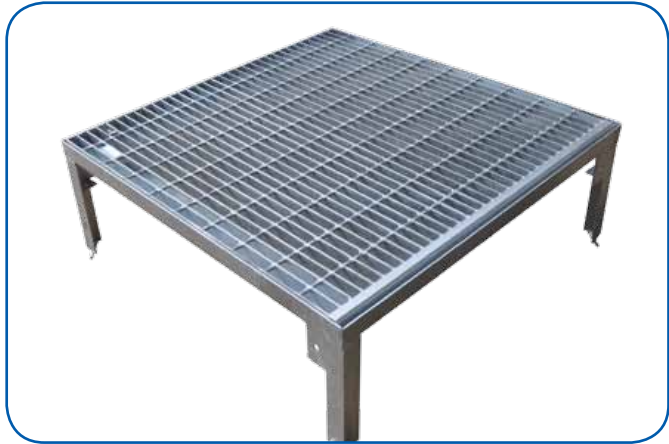
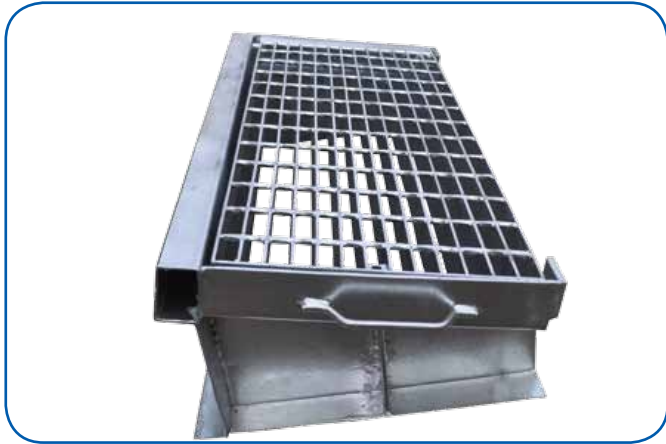

水槽 Water Channel Grating

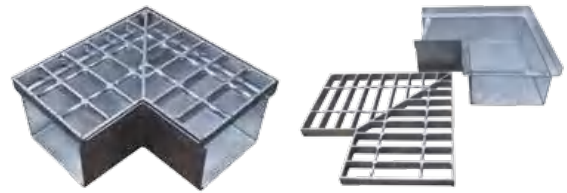
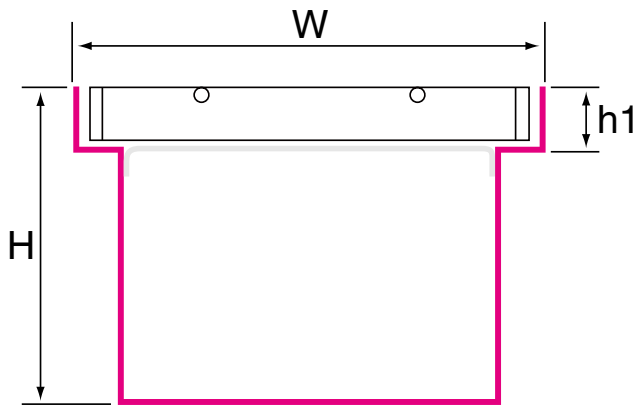

90° 连接器 Angle junction

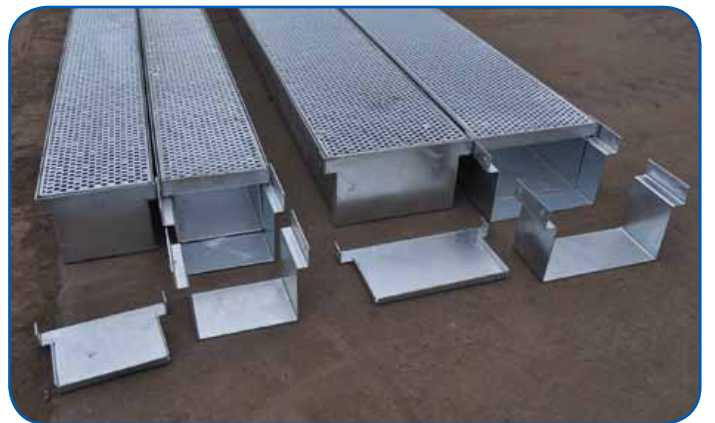
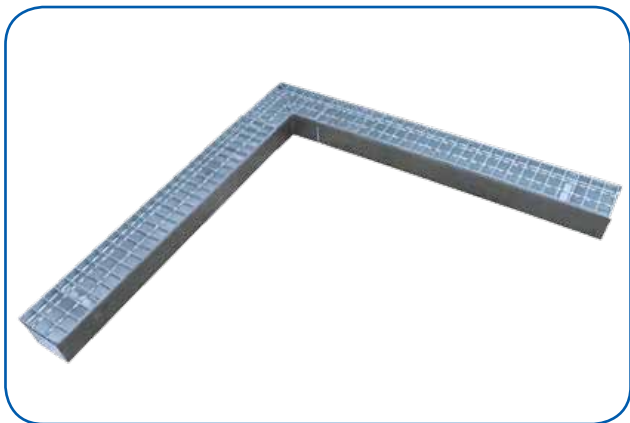
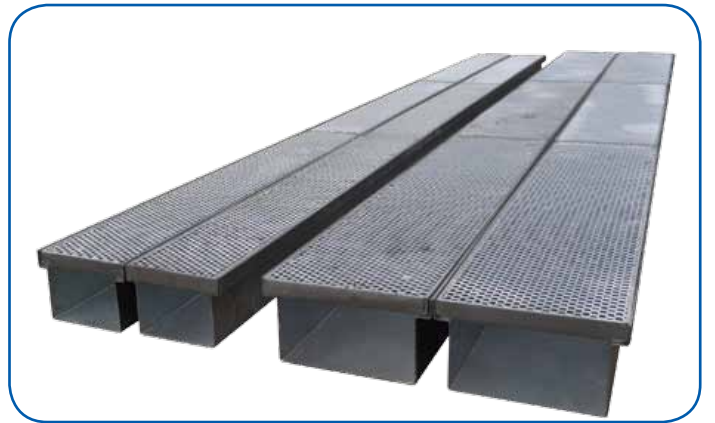
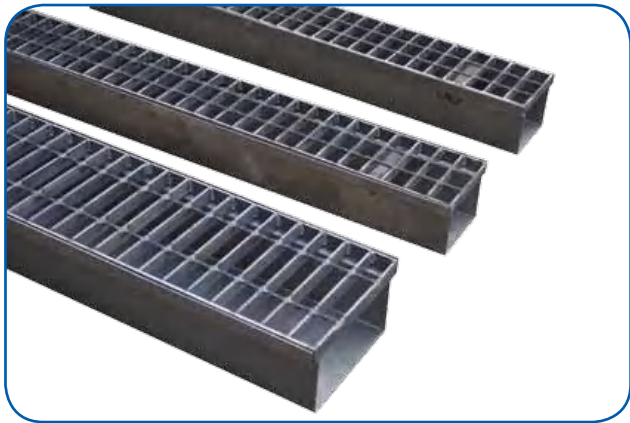

其它产品 Other Products

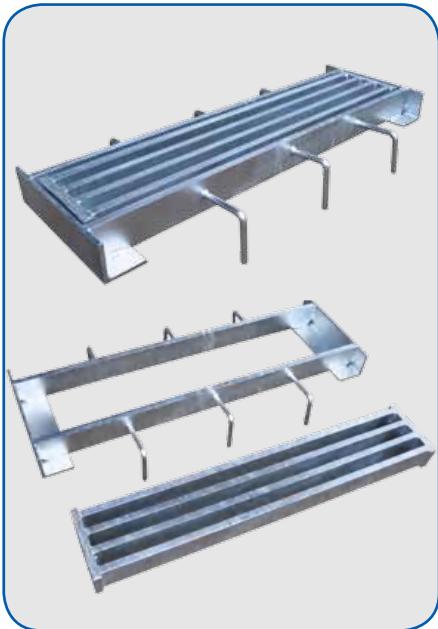
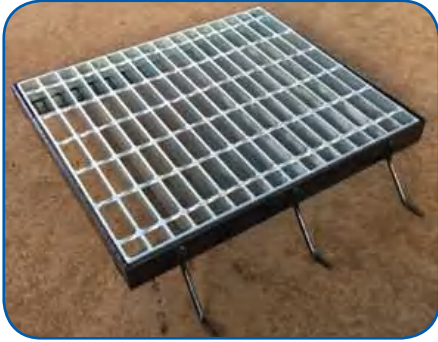

球节点钢管栏杆 Ball Joint Handrail

球节点钢管栏杆分为组合式和片式单元结构两种，根据选用栏杆类型的不同，扶手、横杆与立柱可现场组装，也可分段整体制作成片式单元结构，既经济美观，又牢固耐用，可满足广大用户的不同需求。

栏杆优先选用碳钢材料，表面采用先进的热镀锌工艺处理，抗锈能力强，维护和保养费用低廉；也可根据用户要求选用不锈钢材料，以适用于不同要求的使用场合。

栏杆符合中华人民共和国国家标准 GB4053.3-2009 及全国通用建筑标准设计图集 87J432(JSJT-90) 的规范。

栏杆因其结构新颖多样而广泛应用于任何需要栏杆的地方，如电厂、造船，食品加工、石油化工、市政建设、高档社区等行业，在工业平台、码头、楼梯、走道、园林、水处理系统、设备防护等场合得到广泛的应用。

Ball Joint Handrails are classified into pipe fences, angle bar fences and round bar fences. There are two kinds of pipe fences: ball joint pipe fences and non-ball joint pipe fences. Ball joint ones are made by welding the metallic hollow ball to the pipe. It is available to install the armrest, rods and shaft on the site and produced into units as per customer's request, with good appearance, economical and duration.

Fences are made of the qualified carbon steel and hot galvanized. So they resist the rust and easy to maintain. Fences made of stainless steel and aluminum alloy are also available.

Our fences meet national Standard GB4053.3-2009, and national General Design Standard on construction 87J432(JSJF-90). They are popularly used in the power plant, shipyard, food industry, oil and gas industry, municipal construction, senior community, platform, water treatment, landscape, port, etc.

栏杆标记 / Fence Marking



- 栏杆高度指扶手中心线对钢梁上表面相对高度。
Fence height is the distance between the central line of the handle and the steel soleplates $\phi 42.3$.
- 踢脚板 Toe plate
14 × 25 长孔 Hole
- 栏杆代号：QL— 球节点钢管栏杆；GL— 非球节点钢管栏杆。 Fence Code: QL—Ball Joint Fence; GL—Non-ball Jiont Fence.
- L 轻型：立柱外径 $\phi 42.3$ ，球径 $\phi 65$ 。 L light duty: shaft external diameter $\phi 42.3$, sphero diameter $\phi 65$.
- H 重型：立柱外径 $\phi 48$ ，球径 $\phi 76$ 。 H Heavy duty: shaft external diameter $\phi 48$, sphero diameter $\phi 76$.

组合式球节点钢管栏杆 / Combined Ball Joint Fence

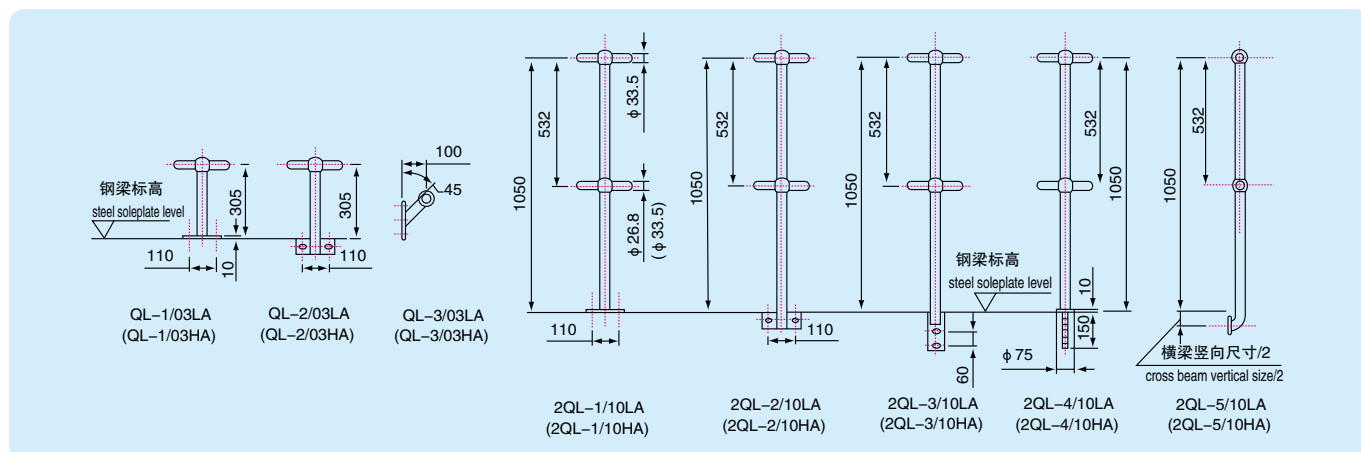

球节点钢管栏杆 Ball Joint Handrail

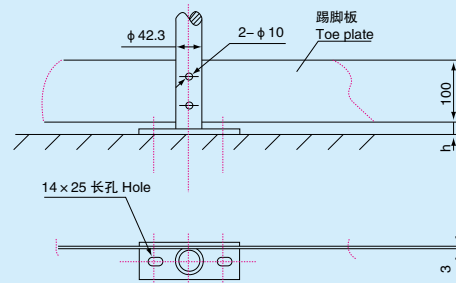
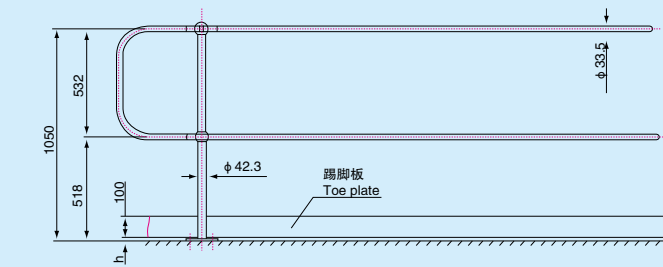
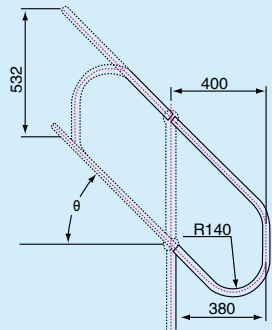
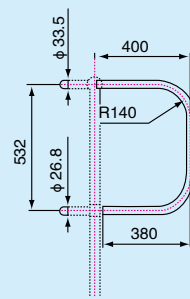
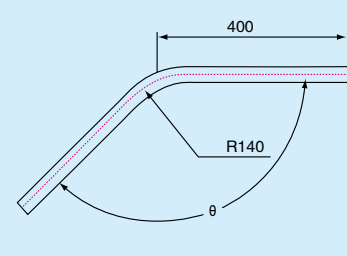
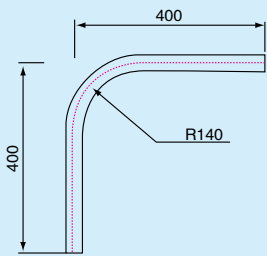
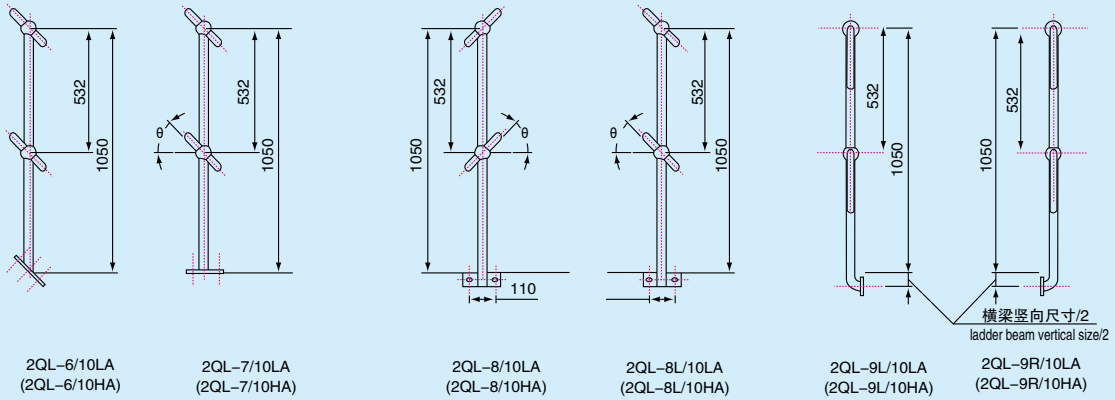

片式单元结构栏杆 / Panel Unit Fence

片式单元结构的栏杆每件长度一般不宜超过 4000mm，每一单元栏杆的方柱数不宜超过 4 个，也可根据顾客的要求和实际情况进行设计。

Usually, each panel unit length is not excess than 4000mm with shafts less than 4. Also we can design the fences as per customers' requests.

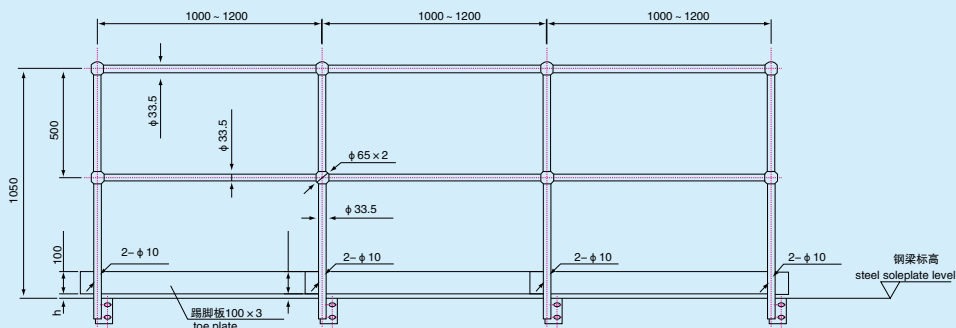

包装与运输 Packaging and Transportation

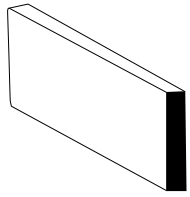

平面扁钢
◎Type F

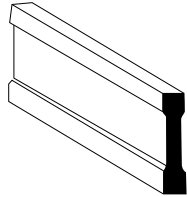

I型扁钢
◎Type I

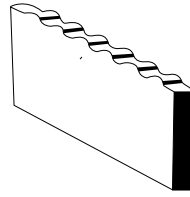

齿型扁钢
◎Type S

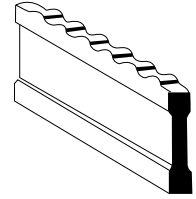

I齿型扁钢
◎Type IS

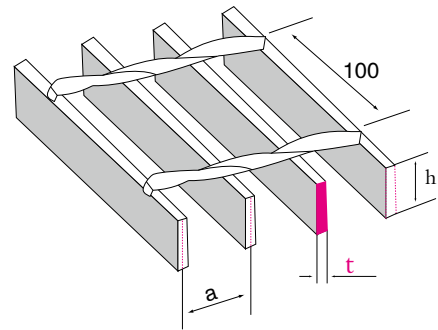
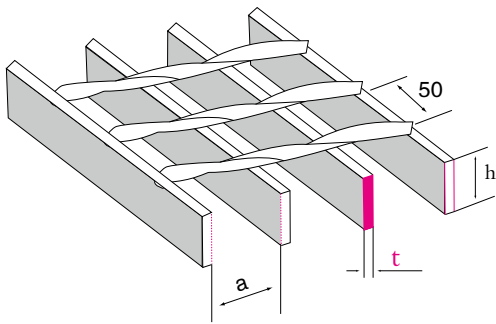

包装与运输 Packaging and Transportation



Төмрийн үнэ ханш тогтворгүй учраас бараа захиалах үедээ тодорхой үнэ авна уу.

因钢材价格不稳定，
客户确认产品之后询问确切价格！